

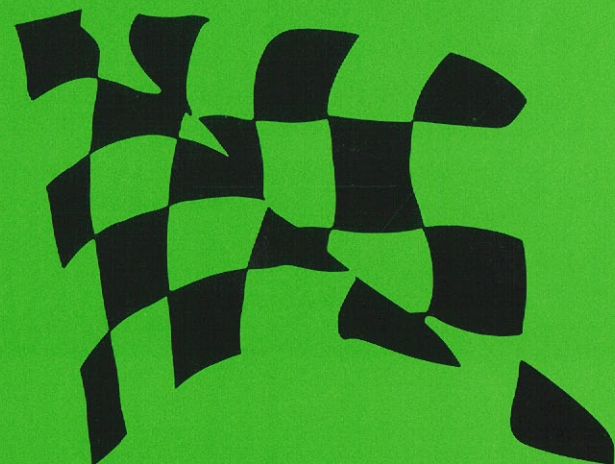

**OWNER'S MANUAL
PARTS LIST**

'98-NSR500V



Important

This machine is designed and manufactured for competition use only and is sold "as-is with no warranty". It does not conform to federal motor vehicle safety standards and operation on public streets, roads, or highways is illegal.

State laws prohibit operation of this vehicle except in an organized racing or competitive event upon a closed course which is conducted under the auspices of a recognized sanctioning body or permit issued by the local governmental authority having jurisdiction.

First determine that operation is legal.

Operator only, no passengers.

Read this manual carefully.

This manual should be considered as a permanent part of the motorcycle and should remain with the motorcycle when resold.

Safety Messages

Your safety and the safety of others is very important. We have provided important safety messages in this manual and on the NSR500V. Please read these messages carefully.

A safety message alerts you to potential hazards that could hurt you or others. Each safety message is preceded by a safety alert symbol  and one of three words, **DANGER**, **WARNING**, or **CAUTION**.

These mean:



You WILL be KILLED or SERIOUSLY HURT if you don't follow instructions.



You CAN be KILLED or SERIOUSLY HURT if you don't follow instructions.



You CAN be HURT if you don't follow instructions.

Each message tells you what the hazard is, what can happen and what you can do to avoid or reduce injury.

Damage Prevention Messages

You will also see other important messages that are preceded by the word **NOTICE**.

This word means:

NOTICE

Your NSR500V or other property can be damaged if you don't follow instructions.

The purpose of these messages is to help prevent damage to your NSR500V, other property, or the environment.

HONDA RACING NSR500V
Owner's Manual

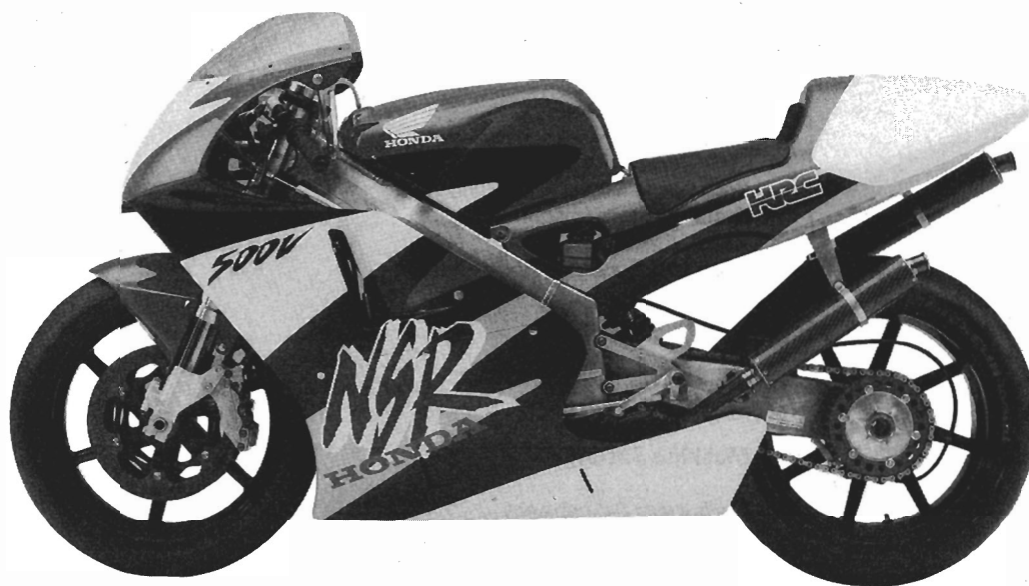

All information in this publication is based on the latest product information available at the time of approval for printing.
HONDA RACING CORPORATION reserves the right to make changes at any time without notice and without incurring any obligation.
No part of this publication may be reproduced without written permission.

Contents

1. Operating Instruction

Fuel	1-1
Coolant	1-1
Basic Operation	1-3
Controls	1-5
Maintenance Stand	1-6

2. Service Data

Specifications	2-1
Service Data	2-1
Optional Parts	2-3
Torque Values	2-4
Lubrication & Seal Points	2-5

3. Service And Maintenance

Maintenance Schedule	3-1
Pre-ride Inspection	3-1
Warming-up Inspection	3-2
Ride Inspection	3-2
After Ride Inspection	3-2
Replacement Parts	3-2
Transmission Oil	3-3
Clutch	3-4
Drive Chain	3-4
Sprockets	3-5
Brake Fluid	3-6
Brake Pad Wear	3-6
Brake System	3-7
Silencer	3-7

4. Engine Servicing

Carburetor	4-1
Ram Air Intake System	4-2
Reed Valve	4-3
Cylinder/Piston/Flap Valve	4-4
RC Valve Adjustment	4-7
Engine Installation	4-8
Water Pump	4-10
Balancer	4-10
Drum Shifter	4-11
Transmission Disassembly/Assembly	4-12
Crankcase Assembly	4-13

5. Frame Servicing

Fork Oil Seal Replacement	5-1
Fork Guide Bushing Replacement	5-1
Steering Stem Installation	5-2
Rear Wheel	5-3
Rear Axle/Eccentric Body	5-4

6. Electrical Servicing

Ignition Timing Adjustment	6-1
Wiring Diagram	6-2

7. Machine Settings

Carburetor Adjustment	7-1
Optional Transmission Gears	7-3
Suspension Adjustment	7-7
Front Suspension Adjustment	7-10
Fork Spring Replacement	7-11
Fluid Level Adjustment	7-12
Rear Suspension Adjustment	7-13

To The New Owner

By selecting a HRC roadracer NSR500V as your new machine, you have placed yourself in a distinguished family of owners and riders.

The NSR is a high performance racing machine utilizing the latest racing technology. This motorcycle is intended for competition use by experienced riders only.

This new racer was designed to be as competitive as possible. But motorcycle racing is a physically demanding sport that requires more than just a fine racing machine. To do well, you must be in excellent physical condition and be a skillful rider. For the best possible results, work diligently on your physical conditioning and practice frequently.

The purpose of this Manual is to help ensure that you obtain the greatest possible satisfaction from your new NSR roadracer.

Importance Of Proper Preparation

Proper pre-race preparation and regular service is essential to rider safety and the reliability of the machine. Any error or oversight made by the technician during preparation or servicing can easily result in faulty operation, damage to the machine, or injury to the rider.

Parts Availability

Orders for the parts tend to be concentrated during the season, so you need to plan your parts orders carefully. To prevent delays in shipment, place orders on regularly replaced and fast-wearing parts well ahead of the season (see page 3-2).

How To Use This Manual

The purpose of this Owner's Manual is to help ensure that you obtain the greatest possible satisfaction from your new NSR roadracer; satisfaction with the performance of the motorcycle, and through success in competition.

If you plan to do any service on your NSR, section 3 describes standard maintenance and sections 4 through 6 contain information on repair, disassembly, assembly and special tools.

Follow the Maintenance Schedule recommendation (page 3-1) to ensure that your NSR is always in peak operating condition.

CAUTION MARK DESCRIPTION

Part : Fuel tank caution
Position : On the top of fuel tank

Part : Rear shock absorber label
Position: On the rear shock absorber reservoir

IMPORTANT NOTICE

THIS VEHICLE IS DESIGNED AND MANUFACTURED FOR COMPETITION USE ONLY. IT DOES NOT CONFORM TO FEDERAL MOTOR VEHICLE SAFETY STANDARDS AND OPERATION ON PUBLIC STREETS, ROADS, OR HIGHWAYS IS ILLEGAL.

STATE LAWS PROHIBIT OPERATION OF THIS VEHICLE EXCEPT IN AN ORGANIZED RACING OR COMPETITIVE EVENT UPON A CLOSED COURSE WHICH IS CONDUCTED UNDER THE AUSPICES OF A RECOGNIZED SANCTIONING BODY OR BY PERMIT ISSUED BY THE LOCAL GOVERNMENTAL AUTHORITY HAVING JURISDICTION.

FIRST DETERMINE THAT OPERATION IS LEGAL.

THIS MOTORCYCLE IS SOLD AS IS WITHOUT WARRANTY AND THE ENTIRE RISK AS TO THE QUALITY PERFORMANCE AND MECHANICAL CONDITION IS WITH THE BUYER

SHOULD THIS MOTORCYCLE PROVE DEFECTIVE FOLLOWING PURCHASE THE BUYER ALONE ASSUMES THE ENTIRE COST OF ALL NECESSARY SERVICING OR REPAIR

•GAS FILLED
•DO NOT HEAT

K21-000

1. Operating Instructions

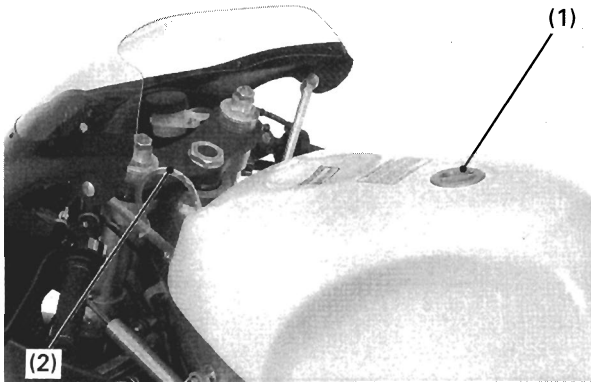

(1) FUEL FILL CAP
(2) FUEL TANK BREATHER TUBE

Fuel

Your NSR500V has a two stroke engine that requires a gasoline-oil mixture as described below.

Gasoline: Premium unleaded gasoline (research octane number of 100 or higher)

Oil: ELF HTX976

Fuel/oil mixing ratio: 25:1

Fuel tank capacity: 26 liter (6.9 US gal, 5.7 Imp gal)

To open the fuel fill cap, turn the tank cap counter-clockwise.

! WARNING

Gasoline is highly flammable and is explosive. You can be burned or seriously injured when refueling.

- Stop engine and keep heat, sparks, and flame away.
- Refuel only outdoors.
- Wipe up spills immediately.

Fuel	Oil
25	1
Liters	cm ³
0.5	20
1.0	40
1.5	60
2.0	80
2.5	100
3.0	120
3.5	140
4.0	160
4.5	180
5.0	200

25:1 FUEL OIL MIXING CHART

- If "knocking" or "pinging" occurs, try a different brand of gasoline or a higher octane grade.
- Premix gasoline and oil in a ratio of 25:1. Prepare the fuel mixture in clean container, and shake until thoroughly mixed before filling the fuel tank. USE ELF HTX976.
- Too much oil will cause excessive smoking and spark plug fouling. Too little oil will cause engine damage or premature wear.
- Do not mix vegetable and mineral based oils.
- Vegetable oils separate from gasoline more easily than mineral oils, especially in cold weather. It is advisable to use mineral oil when ambient temperatures below 0°C (32°F) are expected.
- If the gasoline-oil mixture is left standing in a container for a long period of time, lubricity will deteriorate. Use the mixture within 24 hours.
- Once an oil container is opened, the oil must be used within one month, since oxidation may occur.
- Install the three baffle sponges into the fuel tank.
- After running, to prevent over flow of the carburetor, disconnect the fuel tank breather tube to release the pressure to the atmospheric pressure.

Install the fuel fill cap by turning it clockwise.

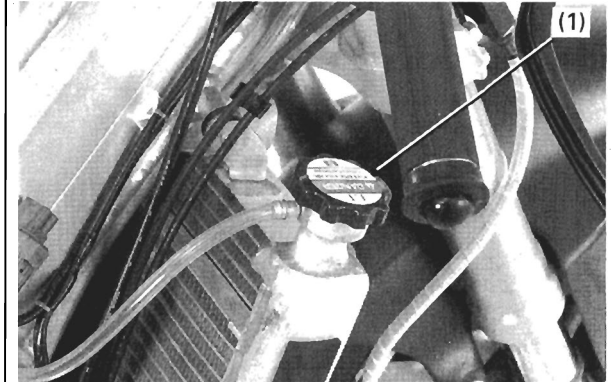

(1) RADIATOR CAP

Coolant

The engine of the NSR500V is a water-cooled type. In order to provide adequate cooling, it is essential that the radiator be filled with coolant up to the proper level.

Coolant: Water only. Use clean tap water or distilled water.

! WARNING

Removing the radiator cap while the engine is hot will allow the coolant to spray out, seriously scalding you.

Always let the engine and radiator cool down before removing the radiator cap.

NOTICE

Failure to bleed the air completely may cause overheating and damage the engine.

Operating Instructions

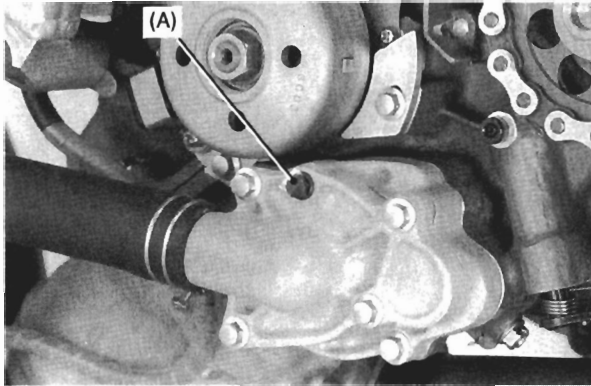

PART A (WATER PUMP)

When filling the cooling system, be sure to bleed air completely by loosening the air bleeder bolts so that the system can be sufficiently filled.

Bleed the air thoroughly using the following procedure:

Raise the front end of the machine and put a stand beneath front wheel.

1. Bleed the air from the water pump (Part A).

Torque: air bleeder bolt: 10 N·m (1.0 kg-m, 7 lb-ft)

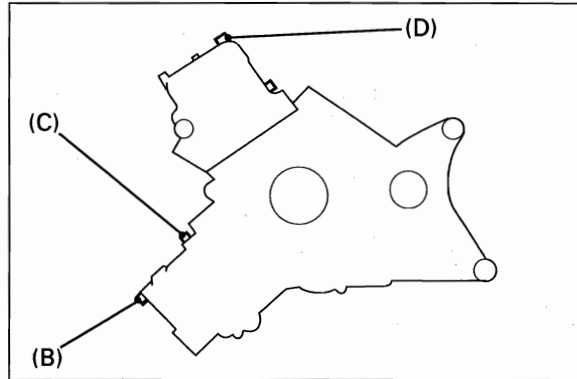

BLEEDING — PART B – D

2. Bleed the air from the front cylinder head (Part B).
3. Bleed the air from the front cylinder (Part C).
4. Bleed the air from the rear cylinder head (Part D).

Torque: air bleeder bolt: 10 N·m (1.0 kg-m, 7 lb-ft)

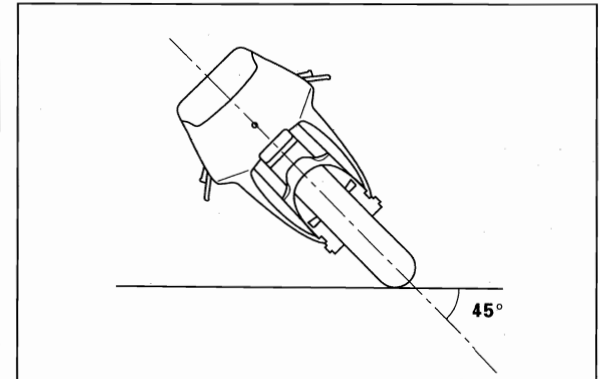

5. Lean the machine 45° degrees and over to the right first.
6. Rock the machine from right to left 2 – 3 times holding the handlebars.
7. Repeat 6 until the water level does not go down.
8. Reinstall the radiator cap and air bleed bolt and tighten securely.

NOTICE

If the radiator cap is not installed properly, it will cause excessive coolant loss and may result in overheating and engine damage.

9. After starting the engine, check the coolant level. The coolant level is correct when it is at the bottom of the radiator filler neck. Add coolant up to the filler neck if the level is low.

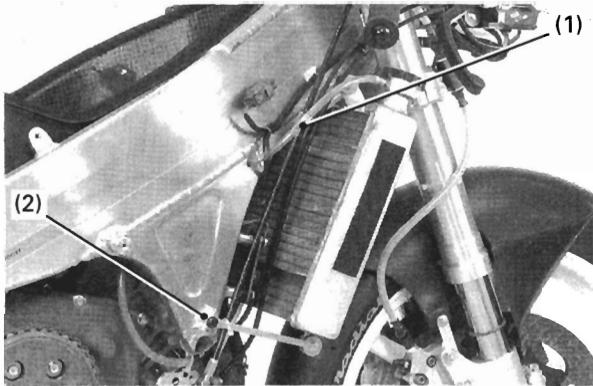

(1) OVERFLOW TUBE (2) DRAIN BOLT

After running, check the radiator and coolant passages for rusting or clogging. Since the cooling system uses water only, it should be drained completely at the end of each race day to prevent corrosion damage. Remove the radiator-to-water pump hose and drain the coolant.

Coolant OverFlow Catch Tank

The front engine hanger pipe of the frame serves as a coolant overflow catch tank to trap coolant vapor from the radiator through the overflow tube. Make sure that the end of the overflow tube is inserted into the hole in the front engine hanger pipe as shown. Before starting, remove the drain bolt to drain coolant from the hanger pipe. Drain the coolant into a suitable container.

After draining, be sure to tighten the drain bolt securely and lock wire it.

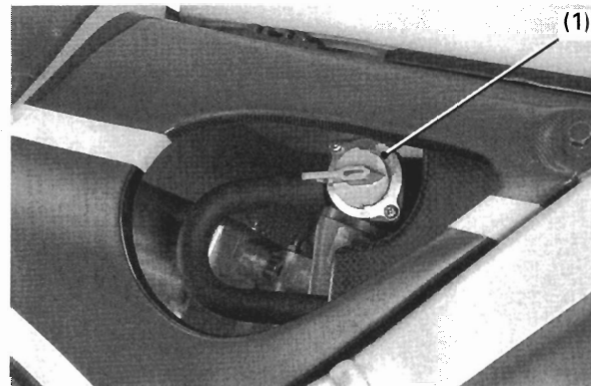

(1) FUEL VALVE

Basic Operation

Starting The Engine

Your NSR500V exhaust contains poisonous carbon monoxide gas. High levels of carbon monoxide can collect rapidly in enclosed areas such as a garage. Do not run the engine with the garage door closed. Even with the door open, run the engine only long enough to move your NSR out of the garage.

1. Turn the engine stop switch to RUN.
2. Turn the fuel valve ON.
3. Shift the transmission into low gear.
4. With the throttle closed, start the engine by pushing the machine.
5. After the engine starts, until it warms up enough to operating temperature (page 1-4).

To improve starting when the engine is hard to start, inject the few fuel into the main bore with oiler or equivalent.

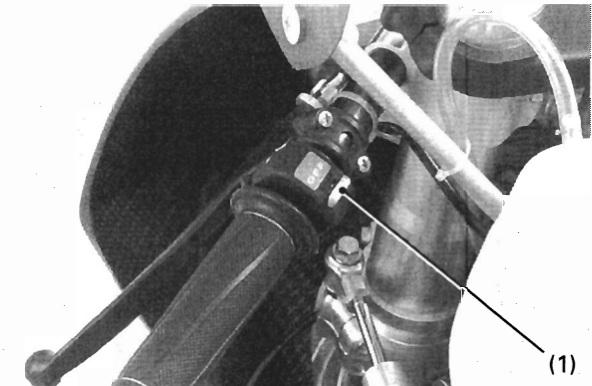

(1) ENGINE STOP SWITCH

Stopping The Engine

1. Shift the transmission into neutral.
2. Turn the fuel valve OFF.
3. Lightly open the throttle 2 - 3 times, and then close it.
4. When the engine slows down, turn the engine stop switch OFF until the engine stops completely.

If the fuel valve is not closed, the fuel could overflow through the carburetor, into the crankcase, causing hard starting.

Operating Instructions

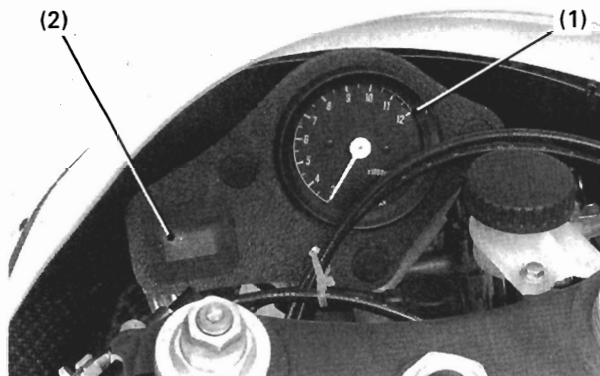

(1) TACHOMETER
(2) WATER TEMPERATURE METER

Warming-up The Engine

NOTICE

- Do not rev the engine more than necessary or engine damage may result.
- Do not race the engine for an extended period of time during the warm-up while the machine is stationary.

1. Vary the engine speed up to a maximum of 6,000 min^{-1} (rpm) until the water temperature meter indicates 50°C (122°F).
2. When the temperature meter indicates more than 50°C (122°F), vary the engine speed to a maximum of 9,000 min^{-1} (rpm) to warm-up the engine.
3. Warm-up the engine for a few minutes until it is heated to the operating temperature [60°C (140°F)].

Break-In Procedure

New Machine

Following proper break-in procedure helps ensure that the most important and expensive components on your new machine will provide maximum performance and service life. (Also follow proper break-in procedure for a newly rebuilt engine.)

When riding a new machine, operate the machine for the first 30 minutes using no more than half throttle and shifting gears so that the engine does not lug:

- Below 6,000 min^{-1} (rpm)...About 50 km (30 mi)
(About 30 minutes)
- Below 7,000 min^{-1} (rpm)...About 15 km (9 mi)
- Below 8,000 min^{-1} (rpm)...About 15 km (9 mi)
- Below 9,000 min^{-1} (rpm)...About 15 km (9 mi)
(About 30 minutes)

Total: About 95 km (57 mi) (About one hour)

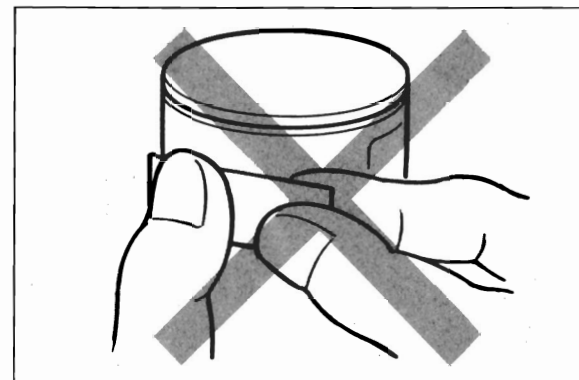

- When refueling, be sure to use a pre-mixed gasoline-oil mixture.
- Raise the main jet number by 2 ranks to enrich the mixture during breaking-in the machine.
- Do not repair the piston sliding surface. Engine damage will result if the piston is repaired.
- After brake-in, check the control cable for elongation.

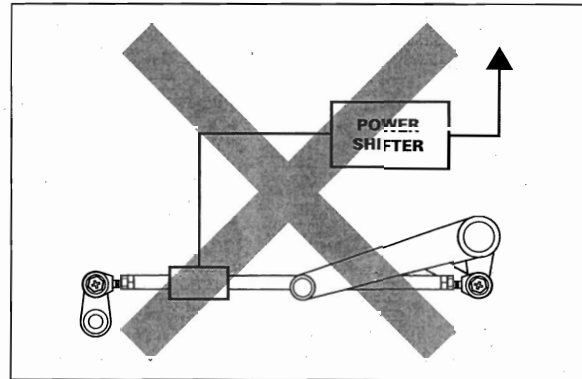

Reconditioned Machine

- After replacing the cylinder and crankshaft, operate the machine for the first 95 km (57 mi; about one hour) observing the same cautions as for a new machine.
- When the piston, piston ring, gears, etc. are replaced, they must be broken in for the first 50 km (30 mi; 30 minutes) using no more than half throttle and shifting gears so that the engine does not lug:

Below 6,000 min⁻¹ (rpm)...About 20 km (12 mi)
 Below 7,000 min⁻¹ (rpm)...About 10 km (6 mi)
 Below 8,000 min⁻¹ (rpm)...About 10 km (6 mi)
 Below 9,000 min⁻¹ (rpm)...About 10 km (6 mi)

Total: About 50 km (30 mi; about 30 minutes)

Controls

Gearshift Pedal

Before running, apply grease to the change pedal pivot surface.

⚠ CAUTION
 Do not use the power shifter. Transmission gear damage will result if the power shifter is used.

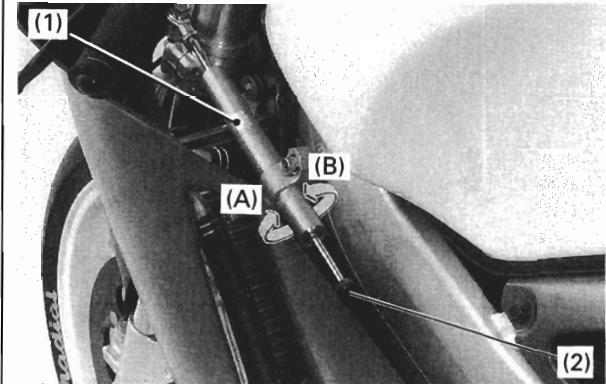

(1) STEERING DAMPER (2) ADJUSTER
 (A) HARD (B) SOFT

Steering Damper

Turn the adjuster clockwise to increase damping, counterclockwise to decrease damping. There are 12 – 17 notches between minimum and maximum. Do not force the adjuster to pass its limit.

Standard setting: Full soft position

NOTICE

Improper handling or failure to install the damper properly may damage the steering damper.

Operating Instructions

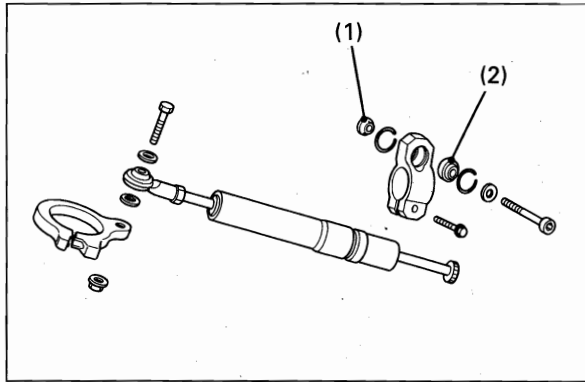

(1) THICK WASHER (2) SPHERICAL BEARING

- When installing the damper on the frame, pay careful attention to prevent the piston rod from being applied with excessive bending force beyond the allowable rotation angle of the spherical bearing.
- Handle carefully to avoid scratching, damaging or leaving foreign substances on the rod.
- Be sure that the adjuster knob on the lock nut of end joint is not touch the steering damper body when making a full turning sweep from left to right.
- Do not try to disassemble the steering damper.
- The steering damper must first be set at the standard (full soft) position, than adjust as required.
- At steering damper installation, set the thick washer (8 mm) between the spherical bearing and frame.



(1) STOPPER (2) AIR VALVE

Maintenance Stand

Use two people to place the NSR500V on the maintenance stand.

! CAUTION

Improper use of the maintenance stand may cause injury.

- **Be sure the maintenance stand is placed on a firm, level ground.**
- **Never ride the machine on the maintenance stand or run the engine while the machine is on the maintenance stand.**
- **Be sure the maintenance stand is fully engaged before working on the machine.**
- **When using the stopper, do not damage the air valve.**

2. Service Data

Specifications

	Item	Specification	
Dimensions	Overall length	1,955 mm (77.0 in)	
	Overall width	595 mm (23.4 in)	
	Overall height	1,050 mm (41.3 in)	
	Wheelbase	1,340 mm (52.8 in)	
	Ground clearance	105 mm (4.1 in)	
	Seat height	810 mm (31.9 in)	
	Half dry weight	109 kg (240 lbs)	
Frame	Type	Aluminum twin tube	
	Front suspension	Telescopic, inverted type	
	Rear suspension	Swingarm, Pro-arm/Pro-link	
	Front brake	Double disc with 4-piston caliper	
	Rear brake	Single disc with 2-piston caliper	
	Fuel tank capacity	26 liter (6.9 US gal, 5.7 Imp gal)	
	Caster angle	22° 30'	
Trail length	91 mm (3.6 in)		
Engine	Type	Liquid cooled, 2-stroke	
	Cylinder arrangement	2 cylinder 100° V	
	Bore and stroke	68 × 68.8 mm (2.68 × 2.71 in)	
	Displacement	499 cm ³ (30.4 cu-in)	
Drive Train	Clutch type	Multi-plate, dry	
	Transmission	6-speed, constant mesh	
	Gearshift pattern	Left foot operated return system 1 - N - 2 - 3 - 4 - 5 - 6	
	Primary reduction	1.963 (53/27)	
	Gear ratio	1st	2.000 (30/15)
		2nd	1.556 (28/18)
		3rd	1.300 (26/20)
		4th	1.190 (25/21)
		5th	1.091 (24/22)
	6th	0.957 (22/23)	
Final reduction	2.313 (16/37)		
Electrical	Ignition system	Digital advanced CDI	
	Ignition timing	27.5° BTDC at 3,000 min ⁻¹ (rpm)	

Service Data

Unit: mm (in)

Item	Standard	Service Limit
Lubrication		
Specified engine oil	ELF HTX976	—
Fuel/oil mixing ratio	25 : 1	—
Transmission oil capacity		
at disassembly	0.55 liter (0.58 US qt, 0.48 Imp qt)	—
at draining	0.53 liter (0.56 US qt, 0.47 Imp qt)	—
Specified transmission oil	ELF HTX740 Viscosity: SAE 75 W	—
Fuel System		
Carburetor identification number	PJ40 short	—
Main jet (Standard)	#1: #220, #2: #200	—
Slow jet (Standard)	#40	—
Jet needle (Standard)	1169/3167/1422	—
Jet needle clip position	3 ROW	—
Air screw initial opening	1 - 1/2 turns out	—
Float level	8.5 (0.33)	—
Throttle grip free play	3.0 (0.12)	—
Cooling System		
Recommended coolant	Clean tap water or distilled water	—
Radiator cap relief pressure	110 – 140 kPa (1.1 – 1.4 kg/cm ² , 16 – 20 psi)	—
Clutch System		
Clutch lever free play	10 – 20 (0.4 – 0.8)	—
Clutch spring free length	40.9 (1.61)	39.0 (1.54)
Clutch plate warpage	—	0.16 (0.006)
Cylinder Head		
Cylinder head warpage	—	0.10 (0.004)
Crankshaft		
Connecting rod small end I.D.	21.004 - 21.012 (0.8269 - 0.8272)	21.022 (0.8276)
Crankshaft side clearance	0.45 - 0.85 (0.017 - 0.033)	0.92 (0.036)
Crankshaft runout	—	0.05 (0.002)

Service Data

Unit: mm (in)

Item	Standard	Service Limit
Wheels/Tires		
Cold tire pressure	210 kPa (2.1 kg/cm ² , 30 psi)	—
Front		
Rear	200 kPa (2.0 kg/cm ² , 29 psi)	—
Front and rear axle runout	—	0.5 (0.02)
Front and rear wheel rim runout		
(Radial)	—	0.3 (0.01)
(Axial)	—	0.3 (0.01)
Drive chain slack	13 ± 2 (0.51 ± 0.08)	—
Drive chain slider thickness	—	2.0 (0.08)
Front Suspension		
Fork tube runout	—	0.20 (0.008)
Specified fork fluid	Showa SR6 (SAE 5 W) or equivalent	—
Fork oil level		
(Standard)	150 (5.91)	—
(Max.)	115 (4.53)	—
(Min.)	210 (8.27)	—
Fork oil capacity		
(Standard)	435 cc (14.7 US oz, 15.3 Imp oz)	—
(Max.)	477 cc (16.1 US oz, 16.8 Imp oz)	—
(Min.)	361 cc (12.2 US oz, 12.7 Imp oz)	—
Compression adjuster standard position	8 th notch back from maximum	—
Rebound adjuster standard position		
(High speed)	8 th notch back from maximum	—
(Low speed)	Minimum position	—
Rear Suspension		
Damper gas pressure	980 – 1,177 kPa (10.0 – 12.0 kg/cm ² , 142 – 171 psi)	—
Damper rod compressed force (at 10 mm compressed)	201 – 242 N (20.5 – 24.6 kg)	—
Shock absorber spring preload length	289 (11.4)	—
Compression adjuster standard position	10 th notch back from maximum	—
Rebound adjuster standard position	12 th notch back from maximum	—

Unit: mm (in)

Item	Standard	Service Limit
Brakes		
Front brake		
brake fluid	AP600 only	—
disc thickness	8.0 (0.31)	7.0 (0.28)
pad (with back plate) thickness	7.0 (0.28)	5.5 (0.21)
Rear brake		
brake fluid	AP600	—
disc thickness	10.2 (0.40)	8.0 (0.31)
pad lining thickness	5.8 (0.23)	1.8 (0.07)
Electrical		
Spark plug (Standard)	NGK: R6120M – 10.5	—
Spark plug gap	0.5 – 0.6 (0.020 – 0.024)	—
Ignition coil resistance		
(Pprimary)	0.5 – 0.7 Ω (20°C/68°F)	—
(Secondary: with plug cap)	12 – 16.5 kΩ (20°C/68°F)	—
(Secondary: without plug cap)	8.3 – 10.2 kΩ (20°C/68°F)	—
Ignition pulse generator coil resistance	85 – 105 Ω (20°C/68°F)	—
Alternator charging coil resistance	0.5 – 2.0 Ω (20°C/68°F)	—

Optional Parts

Engine	Item	Optional
Mainshaft/M1 gear (Standard: 15T)		16T
M2 gear (Standard: 18T)		17T (2 type), 18T (2 type)
M3/4 gear (Standard: 20/21T)		19/20T, 19/21T (2 type), 18/20T, 18/21T (2 type), 20/21T (2 type)
M5 gear (Standard: 22T)		21T, 23T
M6 gear (Standard: 23T)		22T, 23T, 24T
C1 gear (Standard: 30T)		30T, 31T (2 type), 32T
C2 gear (Standard: 28T)		27T, 29T, 30T
C3 gear (Standard: 26T)		27T (3 type), 28T (2 type)
C4 gear (Standard: 28T)		24T, 26T (2 type), 27T
C5 gear (Standard: 24T)		23T, 24T, 25T
C6 gear (Standard: 22T)		23T, 24T
Primary driven gear (Standard: 53T)		52T 54T
Main jet (Standard: #220/200)		#170 - #230 (17 size)
Slow jet (Standard: #42)		#40, #45
Jet needle (Standard: 1169)		1167 - 1172 (5 size)
Throttle valve (Standard: #5.0)		4.5, 5.5
Clutch shim		0.8 - 2.4 mm (5 size) Increments of 0.4 mm

Frame	Item	Optional
Fork spring (Standard: 0.675 kg/mm)		Hard: 0.725 kg/mm Soft: 0.625 kg/mm
Rear shock absorber spring (Standard: 6.0 kg/mm)		Hard: 6.4 kg/mm Soft: 5.6 kg/mm
Driven sprocket (Standard: 16T)		15 T, 17 T
Top/bottom bridge (Standard: 30)		27.5 32.5
Detonation counter unit		—

Service Data

Torque Values

Standard	Item	Torque N·m (kg-m, ft-lb)
	5 mm bolt and nut	5 (0.50, 3.6)
	6 mm bolt and nut	10 (1.0, 7)
	8 mm bolt and nut	22 (2.2, 16)
	10 mm bolt and nut	35 (3.5, 25)
	12 mm bolt and nut	55 (5.5, 40)
	5 mm screw	4 (0.40, 2.9)
	6 mm screw and flange bolt (SH type)	9 (0.9, 6.5)
	6 mm flange bolt and nut	12 (1.2, 9)
	8 mm flange bolt and nut	27 (2.7, 20)
	10 mm flange bolt and nut	40 (4.0, 29)

Engine	Item	Q'ty	Threads	Torque N·m (kg-m, ft-lb)	Remarks
	Cylinder head cap nut	12	8	25 (2.5, 18)	
	Cylinder flange nut	8	10	40 (4.0, 29)	Apply oil
	Upper crankcase flange 9 mm bolt	6	9	35 (3.5, 25)	Apply oil
	Upper crankcase flange 8 mm bolt	3	8	23 (2.3, 17)	
	Upper crankcase 6 mm nut	2	6	12 (1.2, 9)	
	Transmission oil drain bolt	1	10	20 (2.0, 14)	Wire lock
	Primary drive gear bolt	1	10	50 (5.0, 36)	Left hand threads
	AC generator rotor nut	1	12	65 (6.5, 47)	Apply locking agent
	Balancer driven gear bolt	1	10	35 (3.5, 25)	Apply locking agent
	Clutch center lock nut	1	22	110 (11.0, 80)	Apply locking agent
	Drive sprocket flange bolt	1	10	60 (6.0, 43)	Wire lock
	Spark plug	2	14	25 (2.5, 18)	
	Gearshift drum center bolt	1	8	25 (2.5, 18)	Apply locking agent
	Shift drum stopper arm pivot bolt	1	6	12 (1.2, 9)	
	Clutch arm special bolt	1	6	10 (1.0, 7)	Apply locking agent
	Water pump impeller	1	7	12 (1.2, 9)	Left hand threads
	Cylinder head air bleed bolt	2	6	10 (1.0, 7)	
	Cylinder air bleed bolt	2	6	10 (1.0, 7)	
	Air bleed bolt	5	6	10 (1.0, 7)	
	Flap valve arm nut	4	7	20 (2.0, 14)	Apply locking agent
	Transmission oil filler cap	1	20	—	Wire lock
	Transmission holder frange bolt	8	7	22 (2.2, 16)	

Frame	Item	Q'ty	Threads	Torque N·m (kg-m, ft-lb)	Remarks
	Engine hanger adjusting bolt	2	18	8 (0.8, 6)	Apply grease
	Engine hanger adjusting bolt lock nut	2	18	30 (3.0, 22)	
	Engine hanger nut/bolt	4	10	40 (4.0, 29)	
	Steering stem bearing adjusting nut	1	33	See page 5-2	Apply oil
	Steering stem nut	1	35	60 (6.0, 43)	Apply oil
	Fork bottom bridge pinch bolt	4	8	22 (2.2, 16)	
	Fork top bridge pinch bolt	2	8	20 (2.0, 14)	
	Front axle bolt	1	14	62 (6.2, 45)	
	Rear axle nut	1	38	240 (24.0, 174)	Apply grease
	Rear wheel nut	1	46	280 (28.0, 202)	Apply oil
	Swingarm pivot adjusting bolt	1	30	20 (2.0, 14)	Apply grease
	Swingarm pivot adjusting bolt lock nut	1	30	40 (4.0, 29)	Apply grease
	Swingarm pivot nut	1	18	60 (6.0, 43)	Apply grease
	Eccentric body pinch bolt	2	10	30 (3.0, 22)	Apply grease
	Front brake hose oil bolt	4	10	23 (2.3, 17)	
	Rear brake hose oil bolt	2	10	23 (2.3, 17)	
	Front brake oil bleeder bolt	3	8	23 (2.3, 17)	
	Rear brake oil bleeder bolt	2	8	23 (2.3, 17)	
	Rear brake torque rod end bolt	2	8	23 (2.3, 17)	
	Brake bleeder screw	5	8	7 (0.7, 5.1)	
	Front axle holder pinch bolt	4	8	22 (2.2, 16)	
	Handlebar pinch bolt	2	8	22 (2.2, 16)	
	Tw sensor	1	12	11 (1.1, 8)	Apply grease
	Fuel valve lock nut	1	20	19 (1.9, 14)	
	Rear shock absorber top bolt	1	8	25 (2.5, 18)	
	Ride height adjuster lock nut	1	—	35 (3.5, 25)	
	Stay steering damper pinch bolt	1	6	9 (0.9, 6.6)	

Lubrication & Seal Points

Engine	Item	Material	Remarks
	Crankcase mating surface	Three Bond 1207B	Wipe off the excess sealant. Do not apply the sealant to near the bearing.
	Crankshaft journals/bearings Connecting rod big end/small end Piston/piston pin outer surface Piston ring whole surface Cylinder inner surface	ELF: HTX976	
	Transmission gear teeth and sliding surface Mainshaft/countershaft bearings Shift drum bearings Water pump shaft bearing Mainshaft and countershaft spline and gear rotating area	ELF: HTX740 Viscosity: SAE 75W	
	Each O-ring Each Oil seal lips Clutch lifter steel ball	Multi-purpose grease	
	Clutch lifter cam area RC valve needle bearing Flap valve shaft sliding area	Molybdenum paste	
	Shift drum center bolt threads Primary drive gear bolt threads Clutch center lock nut threads Balancer driven gear bolt threads RC valve shaft nut threads Inner rotor nut threads Cylinder stud bolt threads	Locking agent	
	Crankcase 9 mm bolt threads and seating surface Cylinder flange 10 mm nut threads and seating surface Cylinder head cap nut threads and seating surface	ELF HTX 976	Apply for torque stabilizing Apply for torque stabilizing Apply for torque stabilizing

Frame	Item	Material	Remarks
	Handlebar lever pivot bolt surface Cable adjusting bolt threads Front/rear axle shaft surface Rear axle nut threads and seating surface Rear wheel nut threads and seating surface Eccentric body pinch bolt threads Steering head bearings/outer races Rear brake pedal pivot surface Gearshift pedal pivot surface Tw sensor threads Swingarm pivot needle/ball bearing Swingarm pivot dust seal lips Swingarm pivot adjusting bolt threads Eccentric body needle/ball bearing Shock arm needle bearing Engine hanger adjusting bolt threads	Multi-purpose grease	
	Rear caliper piston seal	Silicone grease (KS62F)	
	Silencer inner pipe and mouth cap	Three Bond 1207B	
	Silencer mouth cap and outer casing Silencer socket bolt threads Exhaust chamber and joint contact area	Silicone rubber (KE45)	
	Drive chain slider screw threads Blake hose clamp screw threads Blake hose guide bolt threads Drive chain guide roller bolt threads CHNG PIVOT BOSS	LOCKTITE 271	
	Steering stem bearing adjusting nut thread Steering stem nut threads	ELF HTX 976	
	Handle grip/throttle pipe Fuel tank mounting rubber STEP ARM/STEP ARM/END	Honda bond A or Cemedine #540	Protrusion limit 3 mm max.
	Induction Box seal rubber	ARON ALPHA 903P3 CYANOLIT 903P3	

Memo

3. Service And Maintenance

Maintenance Schedule

Perform the Pre-ride Inspection at each scheduled maintenance period.

I: Inspect and Clean, Adjust, Lubricate or Replace if necessary. C: Clean. R: Replace. L: Lubricate.

Item	Frequency	Each race or about 2.5 hours	Remarks
Throttle Operation		I	
Spark Plug		I	
Transmission Oil		I	R: First 100 km (60 mi) Every race
Cooling System		I	
Cylinder Head Decarbonizing		I	
Flap Valve Decarbonizing		C	
Piston And Piston Ring		C	R: See next page
Piston Pin And Connecting Rod Small End Bearing		I	R: Every 1,000 km (600 mi)
RC Valve		I	Check the alignment of both flap valves (page 4-6)
Crankshaft Oil Seals		I	R: See next page
Reed Valve		I	R: Every 1,000 km (600 mi)
Drive Chain		I•L	R: Every 500 km (300 mi)
Drive Chain Slider		I	
Drive Sprocket		I	
Driven Sprocket		I	
Brake Pad Wear		I	
Brake Fluid		I	R: Every 3 races (after riding in rain)
Brake System		I	
Clutch System		I	
Control Cables		I•L	
Expansion Chamber/Silencer		I	
Suspension		I	
Swingarm/Shock Linkage		C	Over haul at 2,000 km (1,200 mi) or every 3 race
Fork Oil		I	R: First 100 km (60 mi) Every 3 races
Wheels/Tires		I	
Nuts/Bolts/Fasteners		I	

Pre-ride Inspection

For your safety, it is very important to take a few moments before each ride to walk around your NSR500V and check its condition.

WARNING

Improperly maintaining this NSR500V or failing to correct a problem before riding can cause a crash in which you can be seriously hurt or killed.

Always perform a Pre-ride and Pre-race inspection before every ride and correct any problems.

Check the following items before you get on the NSR500V:

- Fuel, oil and water leaks
- Coolant for proper level
- Spark plugs for proper heat range, carbon fouling and spark plug cap terminals for looseness
- Clutch operation and free play
- Steering head bearings and related parts for condition
- Damaged or distorted frame
- Throttle grip and throttle valve operation
- Tires for damaged or improper inflation pressure
- Front and rear suspension for proper operation
- Front and rear brakes, for proper operation
- Drive chain for correct slack and adequate lubrication
- Drive chain slider for damage or wear
- Expansion chamber spring for damage or lack of tension
- Loose bolts, screws and other fasteners (particularly drain bolt lock wire)

Service And Maintenance

Warming-up Inspection

When warming-up the engine:

- Do not rev the engine more than necessary or engine damage may result.
- Avoid overheating the engine by observing the water temperature meter.
- Check for fuel, oil and water leaks
- Warm up the engine for a few minutes until it is heated to the operating temperature until the engine responds to the throttle smoothly [water temperature 50 – 60°C (122 – 140°F)].

Ride Inspection

When running the NSR, check the following:

- Water temperature meter and tachometer
- Carburetor setting
- Gear ratio
- Control system
- Brake stopping power

After Ride Inspection

After riding the NSR, check the following:

- Color condition of piston head and spark plug
- Signs of detonation
- Fuel, oil and water leaks
- Loose or missing bolts and nuts
- Conformity between piston, piston ring and cylinder
- After running, drain the fuel accumulated in the fuel catch tank.
If more than 100 cc is accumulated in a race, check the ram solenoid valve (page 4-2).
- After running, to prevent over flow of the carburetor, disconnect the fuel tank breather tube to release the pressure to the atmospheric pressure.

Replacement Parts

Parts Requiring Periodic Replacement

Item	Replacement Interval	Cause
Engine		
Plug cap	Every 1,000 km (600 mi) (clean every maintenance)	
Cylinder	Every 2,000 km (1,200 mi)	Damage or wear
Piston	Leaded gasoline: Every 400 km (250 mi) Unleaded gasoline: Every 500 km (300 mi)	Damage or wear at skirt
Piston ring	Every 500 km (300 mi)	Damage at ends or wear
Piston pin	Every 1,000 km (600 mi)	Burning, damage or wear
Piston pin clip	Every 500 km (300 mi) (every reassembling)	
Connecting rod small end bearing	Every 1,000 km (600 mi)	Burning, damage or wear
Clutch outer/center	Every 1,000 km (600 mi)	Damage or wear
Crankshaft oil seals	Leaded gasoline: Every 2,000 km (1,200 mi) Unleaded gasoline: Every 3,000 km (1,800 mi)	Damage or wear
Transmission oil	First 100 km (60 mi); thereafter, every race	Contamination or emulsification
Crankshaft Comp (include bearing)	Leaded gasoline: Every 2,000 km (1,200 mi) Unleaded gasoline: Every 3,000 km (1,800 mi)	Damage or distortion
Balancer ball bearing (R side)	Every 1,000 km (600 mi)	
Reed valve	Every 1,000 km (600 mi)	Fatigue or damage
Gear Position SW	Every 2,000 km (1,200 mi)	
Frame		
Drive chain	Every 500 km (300 mi)	Elongation or wear
Front fork fluid	First 100 km (60 mi); thereafter, every 3 races	
Brake fluid	Every 3 races (after riding in rain)	Contamination

- Intervals shown above are for sprint race.
- The repair or replacement of any components that are worn or damaged before the above intervals is not covered by the Warranty.

Fast Wearing/Expendable Parts

Item	Cause
Engine	
Clutch disc, plate	Wear or discoloration
Clutch spring	Fatigue
Drive sprocket	Wear or damage
Spark plug	Worn electrode or damaged insulator
Frame	
Front/rear tire	Wear
Brake pad	Wear
Chain slider	Wear
Driven sprocket	Wear or damage
Expansion chamber spring	Fatigue or damage
Silencer glass wool	Phone over

Transmission Oil

Specified transmission oil: ELF HTX740

NOTICE

Using the wrong oil can damage the transmission.

Oil is a major factor effecting the performance and service life of the transmission. Non-detergent, vegetable, or castor based racing oils are not recommended.

Recommended oil viscosity: SAE 75W

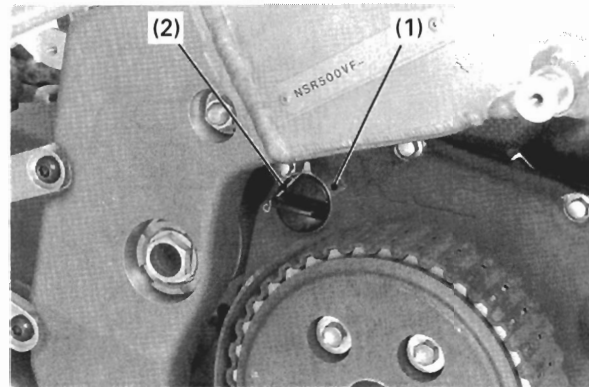

(1) FILLER CAP (2) LOCK WIRE

Oil Change

Change the transmission oil with the engine warm. Support the machine upright to assure complete and rapid draining.

1. Cut and remove the lock wire.
Remove the oil filler cap.

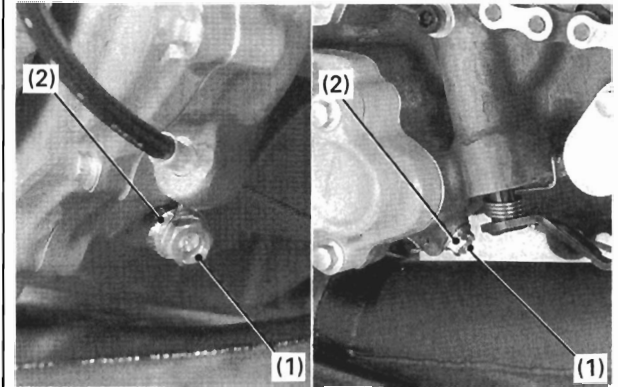

(1) DRAIN BOLT (2) LOCK WIRE

2. Cut and remove the lock wire.
Place an oil drain pan under the engine and remove the drain bolts.
3. After the oil has completely drained, make sure that the sealing washer is in good condition and reinstall the drain bolts. Tighten the drain bolt to the specified torque.

Torque:

10 mm drain bolt: 20 N·m (2.0 kg-m, 14 ft-lb)

Secure the bolts with lock wire.

4. Pour the recommended transmission oil slowly through the oil filler hole.

Capacity:

at disassembly: 0.55 liter (0.58 US qt, 0.48 Imp qt)
at draining: 0.53 liter (0.56 US qt, 0.47 Imp qt)

Install the oil filler cap.
Secure the cap with lock wire.

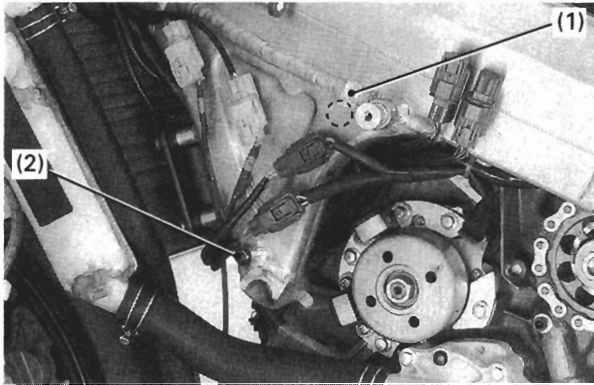

- (1) BREATHER TUBE (REVERSE SIDE)
(2) DRAIN BOLT

Oil Catch Tank

The front engine hanger pipe of the frame serves as an oil catch tank to trap oil bled from the crankcase through the breather tube. Make sure that the end of the crankcase breather tube is inserted into the hole in the reverse side of the front engine hanger pipe. Before starting, remove the drain bolt to drain oil from the hanger pipe into a proper container.

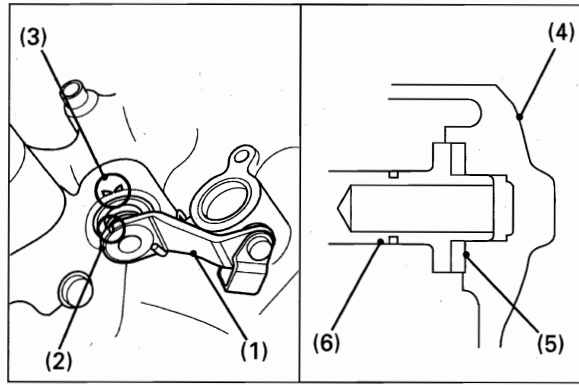

- (1) CLUTCH LEVER ARM (2) CUT-OUT
(3) INDEX MARK (4) PRESSURE PLATE (5) SHIM
(6) CLUTCH LIFTER

Clutch

Clutch Shim

When rebuilding the clutch or if it starts to slip while riding, use the following procedure to verify proper clutch function.

1. Remove the clutch cable from the clutch lever arm (crankcase end).
2. Turn the clutch lever arm clockwise (as viewed from the bottom) until resistance is felt. Check the cut-out location in relation to the index mark on the crankcase.
3. Remove the pressure plate then raise the thickness of the shim by 1 size if the cut-out is on the right side of the index mark.

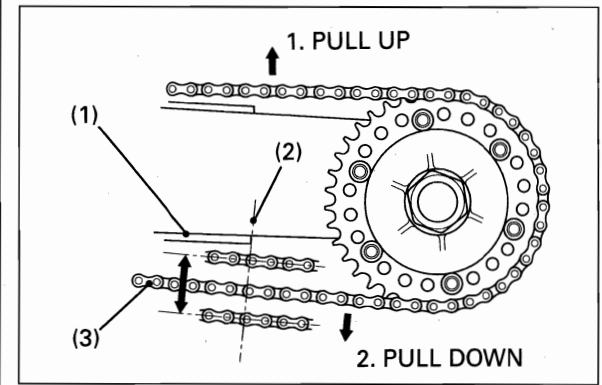

- (1) DRIVE CHAIN SLIDER (2) MEASURING POINT
(3) DRIVE CHAIN SLACK

Drive Chain

Drive Chain Slack Inspection

During the break-in period, drive chain slack should be checked and adjusted often. Also check the drive chain slack after the drive chain replacement.

Turn the engine off and place the machine on the maintenance stand.

With the transmission in neutral and measure the chain slack as follows:
Place the measure align the end of drive chain slider as shown.

1. Pull up the drive chain upper section with your finger and read the measure.
2. Pull down the drive chain lower section with your finger and read the measure.
3. Calculate the drive chain slack.

Drive chain slack: 13 ± 2 mm (0.51 ± 0.08 in)

Rotate the wheel and chain slack in several sections. If slack in one section increases beyond the standard measurement, this indicates the chain has stretched and needs to be replaced.

Take care to prevent catching your fingers between the chain and sprocket.

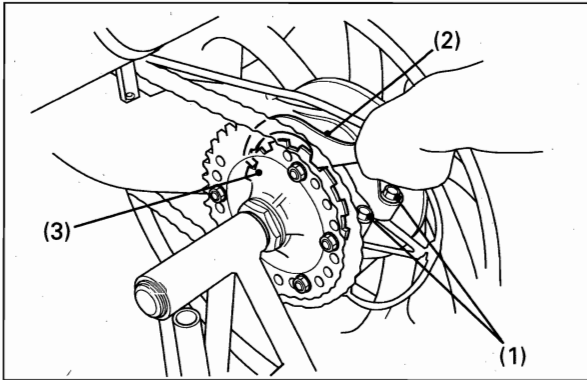

(1) PINCH BOLTS (2) PIN SPANNER
(3) ECCENTRIC BODY

Drive Chain Slack Adjustment

Loosen the eccentric body pinch bolts.
Turn the eccentric body with the pin spanner until the correct drive chain slack obtained.

TOOLS:
Pin spanner **89201-MR7-000**
Wrench handle, 120 mm **89217-422-000**

Improper chain adjustment can affect performance.
Be sure it is adjusted properly.

Tighten the eccentric body pinch bolts.

Torque: 30 N•m (3.0 kg-m, 22 ft-lb)

Recheck the drive chain slack and free wheel rotation.

Check the ride height, adjust if necessary (page 7-7).
Lubricate the drive chain.

Drive sprocket \ Driven Sprocket	15	16	17
35	112L	112L	114L
36	112L	112L	114L
37	112L	114L	114L
38	114L	114L	114L
39	114L	114L	114L
40	114L	116L	116L

Sprockets

Optional drive and driven sprockets and drive chains are available.
Select the drive sprocket, driven sprocket and drive chains as a set according to the above chart.

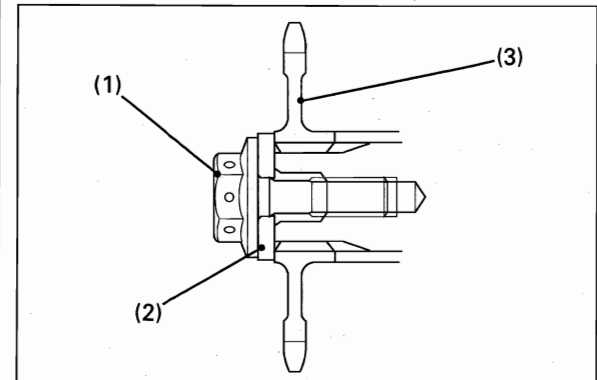

(1) BOLT (2) WASHER (3) DRIVE SPROCKET

Drive Sprocket Replacement

Remove the lower cowl.
Loosen the drive chain (page 3-5).

Cut and remove the lock wire.
Place the rear wheel on the ground.
Shift the transmission into low gear, apply rear brake.

Remove the following:
- Drive sprocket bolt
- Washer
- Drive sprocket

Install the drive sprocket with its etched number (number of teeth) facing outward.
Install the washer as shown.

Place the rear wheel on the ground.
Shift the transmission into low gear, apply rear brake.
Tighten the drive sprocket bolt to the specified torque.

Torque: 60 N•m (6.0 kg-m, 43 ft-lb)

Secure the drive sprocket bolt with a lock wire.

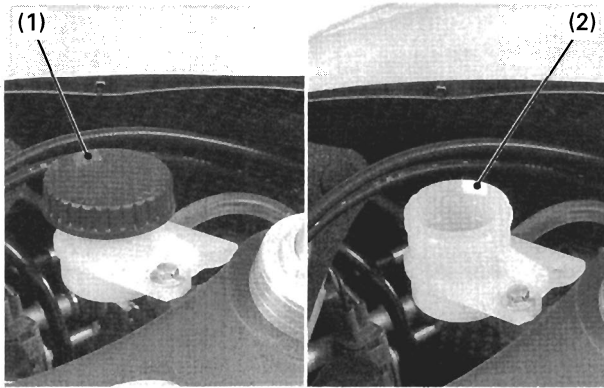

(1) COVER (2) FLUID LEVEL

Brake Fluid

Front Brake Master Cylinder

Always inspect the brake fluid level, and relief the vacuum pressure in the reservoir.

Remove the master cylinder cover, set plate and diaphragm.

If the fluid level is lower than the lower level, check for the brake pad wear.
Replace the brake pad if necessary.

Also check the brake system for leaks.

Check that the brake hose do not bind or kink in all steering position, and is not pulled when the suspension is extended.

Replace the brake fluid after every three race.
Do not service the brake system in high humidity.
Replace the brake fluid after riding in the rain.

Brake fluid: AP600 Only

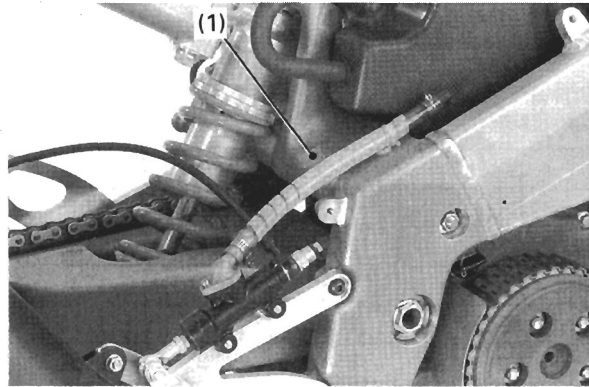

(1) VINYL TUBE

Rear Master Cylinder

The rear master cylinder uses a vinyl tube in place of the reservoir.

Always inspect the brake fluid level, and relief vacuum pressure in the tube.

Fluid level: 40 – 50 mm (1.6 – 2.0 in) from the top of the tube

If the fluid level is low, check the brake pad for wear.
Replace the brake pads if necessary.

Replace the brake fluid after every three race.
Do not service the brake system in high humidity.
Replace the brake fluid after riding in the rain.

Brake fluid: AP600

The vinyl tube will harden over time so it should be replaced every 6 months.

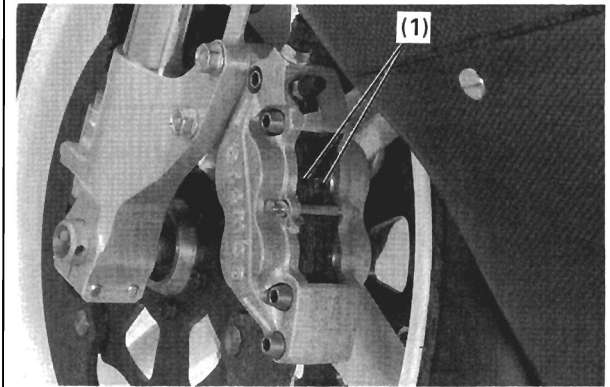

(1) BRAKE PADS

Brake Pad Wear

Inspect the brake pads visually to determine the pad wear.

If either pad is worn anywhere to a thickness of 5.5 mm (0.21 in), both pads must be replaced.

If the lever feels judder or increase in free play when operated, replace the brake pads and disc as a set.

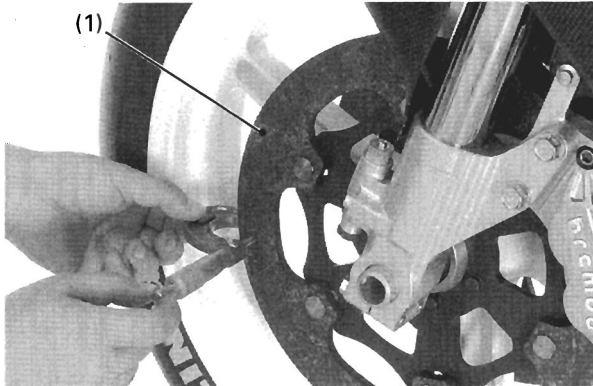

(1) BRAKE DISC

Brake System

Brake Discs

Measure the brake disc thickness.

Service limit: Front: 7.0 mm (0.28 in)
Rear: 8.0 mm (0.31 in)

Replace the brake disc if necessary.

If the lever feels judder or increase in free play when operated, replace the brake pads and disc as a set.

To purchase the front brake parts or service and maintenance for front brake system, consult a BREMBO S.p.a.

BREMBO S.p.a.

Divisione sistemi frenanti
 Mrs. Enrica Mangili (commercial office)
 Mr. Eugenio Gandolfi (technical office)
 Via Brembo, 25
 24035 CURNO (BG)
 ITALY

Tel. +39 (0) 35 / 60. 51. 11
 Fax. +39 (0) 35 / 40. 12. 00

Silencer

Glass Wool Replacement

The silencer consists of an inner pipe, outer casing, and noise-absorbing glass wool.

To replace the glass wool:

1. Remove the silencer from the silencer joint.
2. Drill off the heads of 8 rivets at the rear end of the outer casing. Press the rivets down into the casing using a 3 mm pin or rod.
3. Remove the inner pipe from the outer casing.

4. Remove the glass wool from the outer casing. Install the new glass wool (9 μ , 142 g) onto the inner pipe.
5. Apply Three Bond 1207B or equivalent sealant to the mating surface between the inner pipe and mouth cap. Then slide the inner tube and glass wool into the outer casing. Apply silicon rubber (KE45) to the mating surface between the mouth cap and outer casing. Install the mouth cap aligning the rivet holes between cap and outer casing.
6. Drive 8 stainless pop rivets (3.2 \times 6.4 mm) through the holes in the outer casing after applying epoxy based adhesive.
7. When installing the silencer on the silencer joint, apply silicon rubber (KE45) to the mating surface and socket bolts, and tighten the bolts gradually.

Memo

4. Engine Servicing

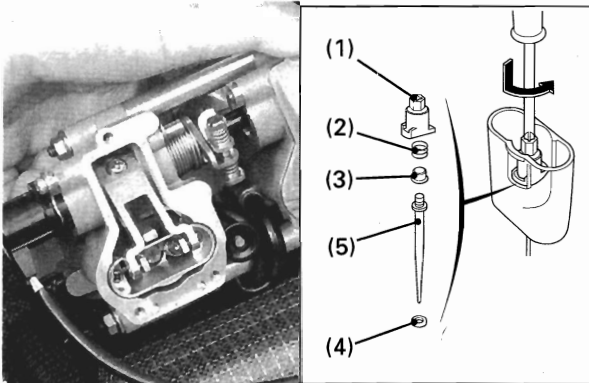

(1) CABLE HOLDER (2) SPRING (3) SEAT
(4) SHIM (5) JET NEEDLE

Carburetor

Jet Needle Removal/Installation

Turn the fuel valve OFF and remove the fuel tank.

Remove the screws and carburetor top.
Lift the bottom of the throttle valve with your finger.

Push down on the jet needle holder and turn it 90 degree. Remove the jet needle holder, spring, spring seat, shim and jet needle.

Inspect both the straight portion and tapered portion of the jet needle for wear and replace if necessary. Inspect the jet needle clip groove for wear or damage and replace if necessary.
The jet needle should be replaced every season.

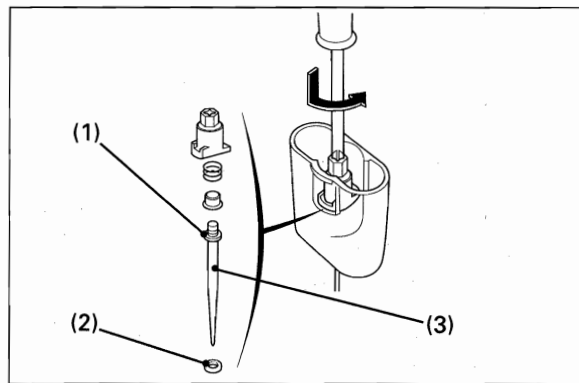

(1) CLIP (2) SHIM (3) JET NEEDLE

Fine adjustment of the jet needle setting is conducted by changing the positions of the clip and shim. For delivery (i.e., normal position), the shim is positioned below the clip. However, it is possible to change the jet needle setting by minus 0.5 step by leaving the clip in the original position and moving the shim to a location above it.
Be sure to set the shim either above or below the clip.

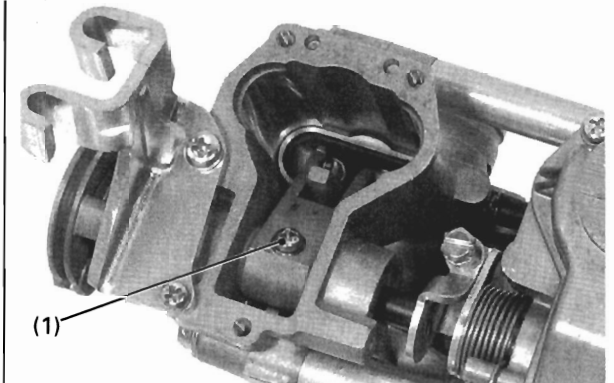

(1) THROTTLE ARM SCREW/WASHER

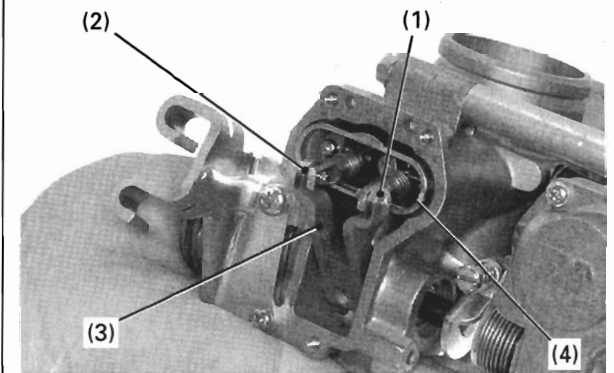

(1) THROTTLE VALVE LINK (2) LINK SPRINGS
(3) THROTTLE VALVE ARM (4) THROTTLE VALVE

Throttle Valve Removal/Installation

Remove the screws and carburetor top.

Remove the throttle valve arm screw and washer. Remove the throttle valve link springs from the throttle arm, then remove the link spring, throttle valve link and throttle valve.

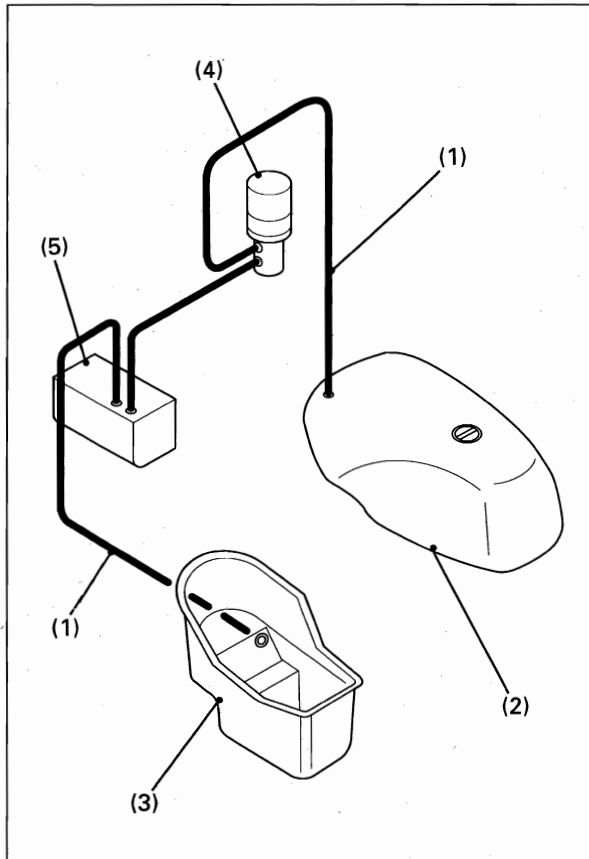

(1) FUEL CATCH TANK TUBE/BREATHER TUBE
 (2) FUEL TANK (3) CARBURETOR BOX
 (4) RAM SOLENOID VALVE (5) FUEL CATCH TANK

Ram Air Intake System

When the NSR500V is running, the carburetor box is ram-charged, and this pressure is also applied fuel in the carburetor float chamber. On the NSR, the ram pressure in the carburetor box is applied to the inside of the fuel tank through the catch tank tube and the catch tank breather tube to balance the pressures applied to the fuel in the carburetor (Ram pressure) and in the fuel tank.

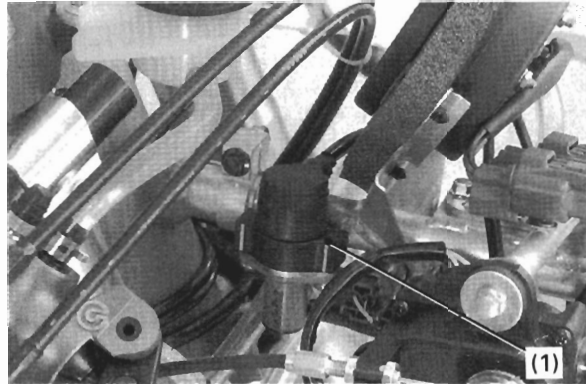

(1) RAM AIR SOLENOID VALVE

When the throttle is closed (when decelerating), the ram solenoid valve operates to close these passages.

If the ram pressure generated in the carburetor box is not transferred to the fuel tank and the pressure in the carburetor is higher than in the fuel tank, the carburetor float level is lowered and causes the symptom similar to the lack of fuel at full throttle in 5th and 6th gear.

When the symptom like above is observed, check each tube for binding and disconnection, the ram solenoid valve and the throttle sensor.

Inspection

Check the fuel catch tank tube and catch tank breather tube for deterioration, damage, loose connections or clogging.

- After running, drain the fuel accumulated in the fuel catch tank.
 If more than 100 cc is accumulated in a race, check the ram solenoid valve.
- After running, to prevent over flow of the carburetor, disconnect the fuel tank breather tube to release the pressure to the atmospheric pressure.
- When the tank is removed, check the sponge located between the fuel tank and the carburetor box for damage or peeling.

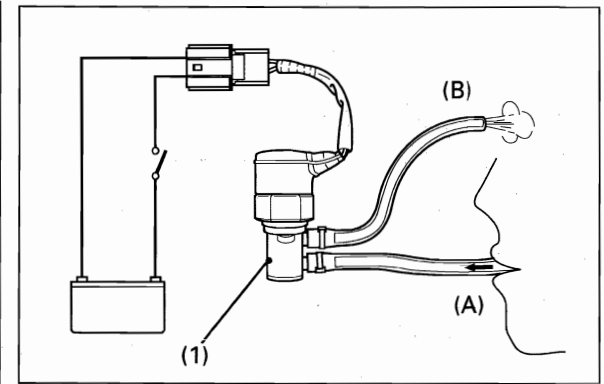

(1) RAM AIR SOLENOID VALVE

Ram Solenoid Valve

Connect the suitable tubes to the ram solenoid valve. Disconnect the ram solenoid valve 2P connector from the main wire harness.

Connect the full charged 12 V battery to the solenoid valve 2P connector (Black: +, Pink: -), air should not flow A to B. Disconnect the battery, air should flow A to B.

If the ram solenoid valve operation is incorrect, replace the ram solenoid valve.

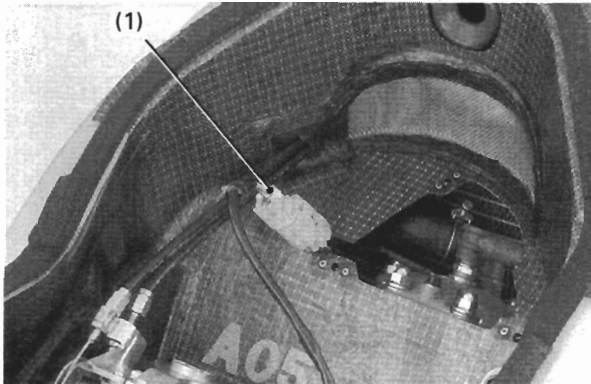

(1) THROTTLE SENSOR CONNECTOR

Throttle Position Sensor

Disconnect the throttle position sensor connector and measure the resistance between the Yellow/Blue and Green/Blue terminals when throttle is closed.

Standard: 0.7 – 0.8 kΩ (20°C/68°F)

Check the resistance between the Yellow/Blue and Green/Blue terminals when throttle is opened.

Standard:

Open the throttle: increase resistance
Close the throttle: decrease resistance

Replace the throttle position sensor if it is out of specification when open or close the throttle.

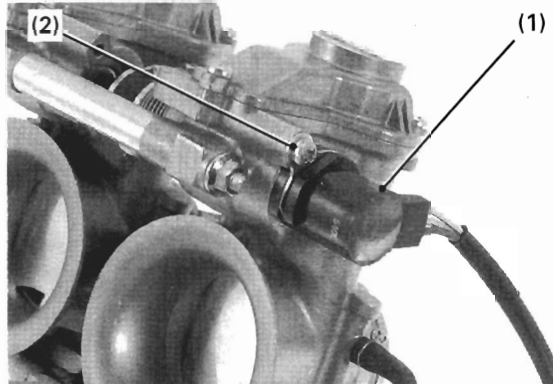

(1) THROTTLE SENSOR (2) SCREW

Use this procedure to adjust throttle sensor setting if the throttle sensor removed or replaced.

Measure the resistance between the Yellow/Blue and Green/Blue terminals when throttle is closed and adjust the resistance by turning the sensor.

Standard: 0.7 – 0.8 kΩ (20°C/68°F)

Tighten the throttle sensor mounting screw and recheck the resistance.

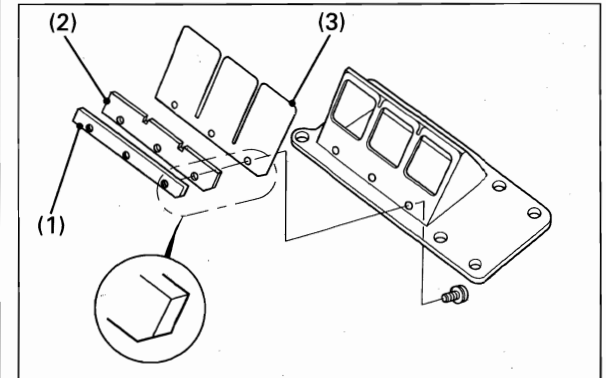

(1) FRONT REED VALVE STOPPER
 (2) REED VALVE STOPPER (3) REED VALVE 0.42

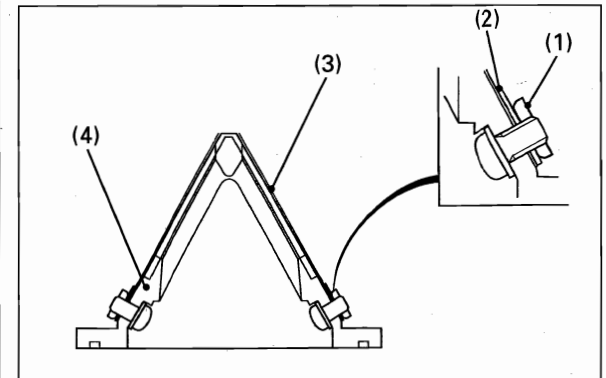

(1) FRONT REED VALVE STOPPER
 (2) REED VALVES STOPPER (3) REED VALVE 0.42
 (4) REED VALVE BODY

Reed Valve

Disassembly/Assembly

Install the reed valves and reed valve stoppers as shown.

Because it has a flat surfaces, both sides of a reed valve can be used. In situations where one side of reed valve becomes separated, use the reverse side.

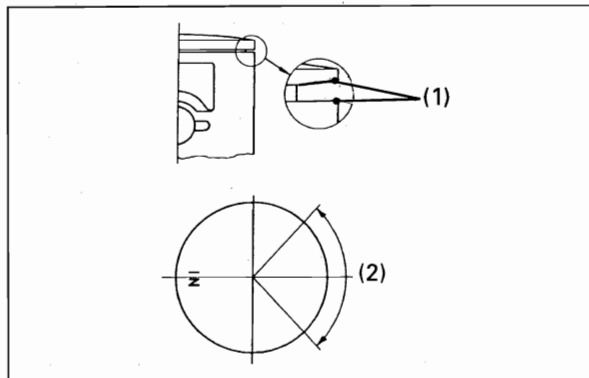

(1) CHAMFER (2) AREA TO BE CHAMFERED

Cylinder/Piston/Flap Valve

Piston/Piston Ring

The specified piston must be used for this model. Always inspect the piston crown for cracking or other damage.

Also inspect the piston ring for sticking.

To prevent a stuck piston in the cylinder, chamfer the ring groove with an oil stone and cutting oil as shown before installing a new piston.

After breaking in, check for sticking. If there is any evidence of piston sticking, observe the following procedures:

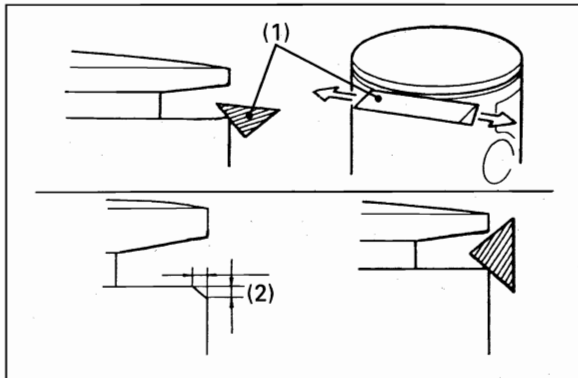

(1) OIL STONE (2) 0.3 mm (0.012 in)

1. Sand off high spots or ridges with fine (#600) emery cloth by sanding around the piston, not up and down the sides.
2. On one portion of the ring groove, carefully chamfer the upper and lower edges to about 0.3 mm on each side (see illustration). Then, continue chamfering the remaining area of the ring groove.

Area to be chamfered: 0.3 mm (0.012 in)

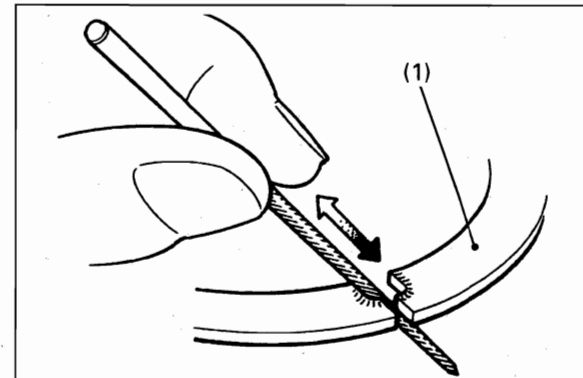

(1) PISTON RING

3. To prevent scuffing by the ring ends, dress the ends to about 0.2 mm with a round file.

Area to be chamfered: 0.2 mm (0.008 in)

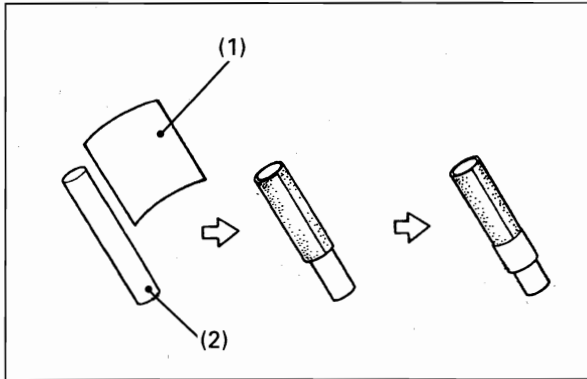

(1) SAND PAPER (2) DOWEL

Cylinder Maintenance During Piston Replacement

Piston replacement is scheduled for every 500 km. Minor maintenance of the cylinder at that time can reduce piston friction.

Use a very gentle touch and sand the cylinder bore using a #600 – 800 sand paper with a side motion. Do not touch the thin bridge portion of the cylinder.

Wrap a 25 × 60 mm piece of #600 – 800 sand paper around a dowel and tape it in place.

NOTICE

Do not use the cylinder more than 2,000 km (1,200 mi). It may cause of crack or other trouble.

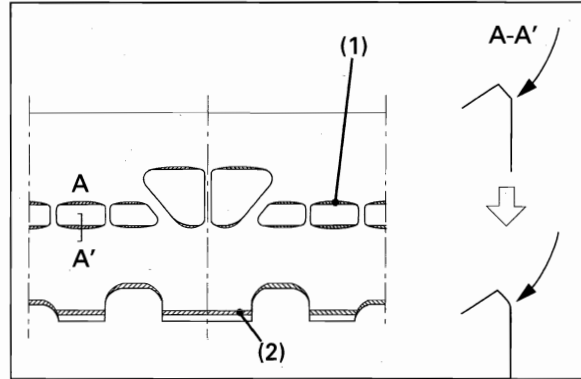

(1) CYLINDER PORT
(2) CYLINDER BORE AT CYLINDER SKIRT

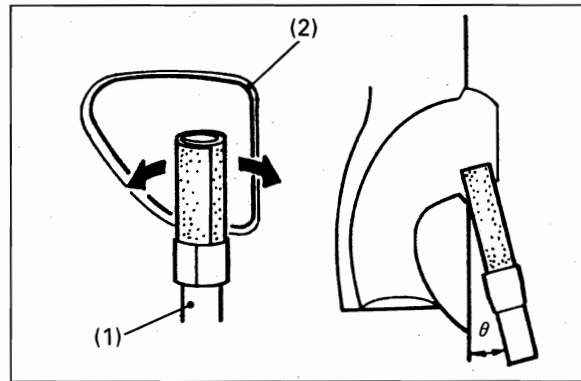

(1) DOWEL (2) PORT

Intake port

Soak the sandpaper in clean machining oil. Use the dowel to remove residue from the chamfered edge of the ports. Use a very gentle touch and sand the edge with a side to side motion. Try to achieve a smooth, rounded edge where the chamfer meets the cylinder wall. The plating on the cylinder wall is very fragile. Do not use a grinder or file on this surface.

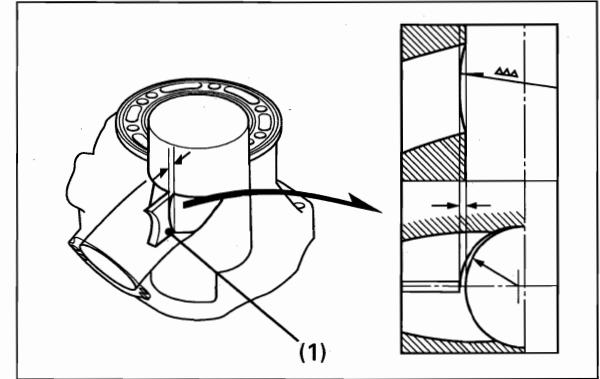

(1) RECESSED SECTION

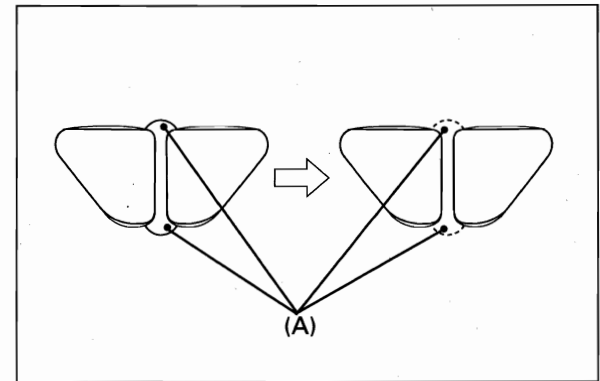

(A) EDGE

Exhaust port

The bridge between the exhaust ports(see illustration) is recessed so that exhaust gas residue will be deposited in this area. If the edge A of this recess is too sharp, use # 600 – 800 sandpaper to round the edge. Sand gently, with a side motion.

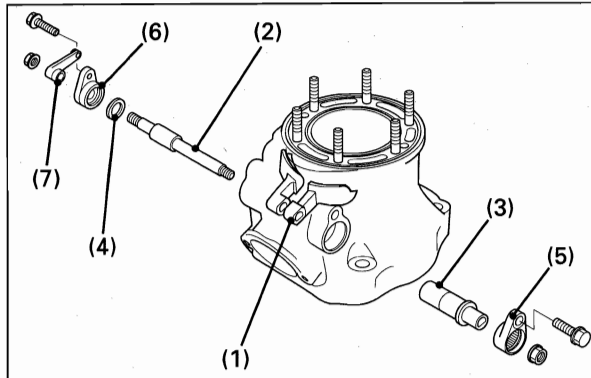

(1) FLAP VALVE (2) FLAP VALVE SHAFT
 (3) SHAFT COLLAR (4) SHIM (5) OIL SEAL
 (6) SHAFT HOLDER (7) VALVE ARM

Flap Valve Replacement

Apply molybdenum paste the following:

- Flap valve shaft
- Flap valve shaft collar
- Needle bearing
- Oil seal lip

Install the following:

- Flap valves
- Flap valve shaft
- Oil seal
- Shim
- Valve shaft holders
- Valve arm

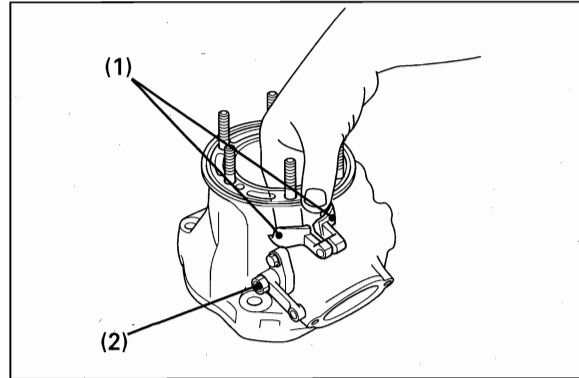

(1) FLAP VALVE (2) VALVE ARM NUT

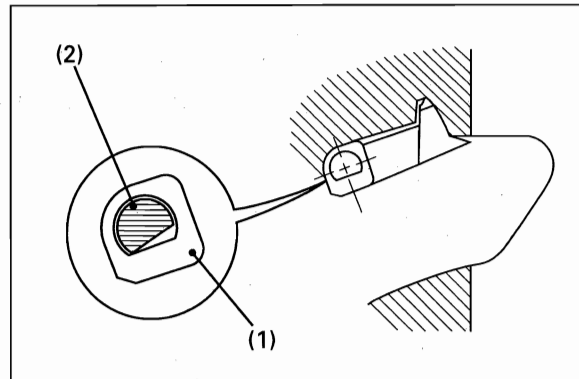

(1) FLAP VALVE (2) FLAP VALVE SHAFT

Coat the threads with locking agent before installing the valve arm nut.

Hold the valve in the high position and turn the flap valve shaft counterclockwise until it stops.
 Tighten the valve arm nut to the specified torque.

Torque: 20 N·m (2.0 kg-m, 14 ft-lb)

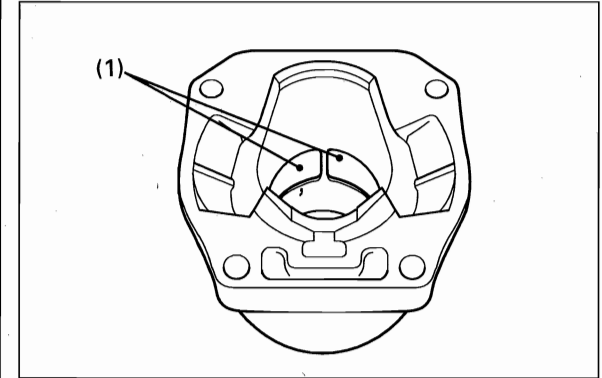

(1) FLAP VALVE

After Installation, check the valve for following:

- That the valve moves smoothly.
- The alignment of both valves.

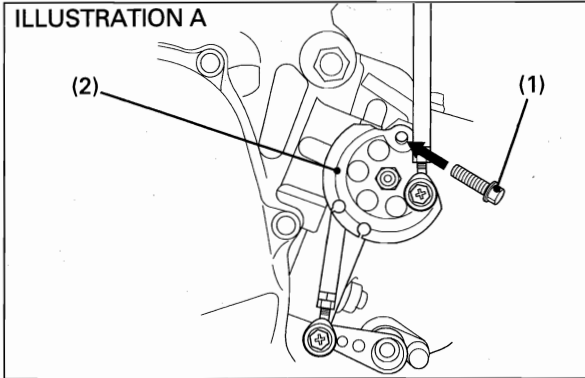

(1) BOLT (2) DRIVEN PULLEY

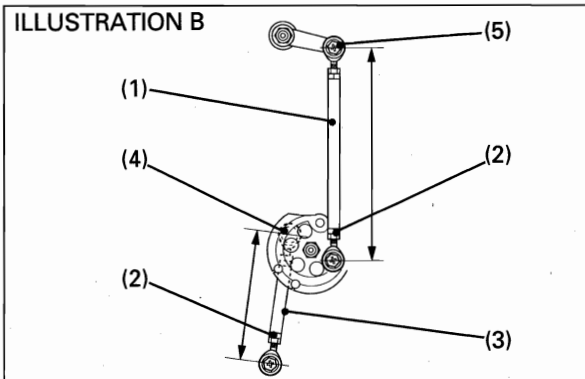

(1) REAR ROD (2) LOCK NUTS (3) FRONT ROD
(4) PULLEY ARM (5) VALVE ARM

RC Valve Adjustment

RC Valve Linkage Adjustment

Screw a proper 6 mm threads bolt in the driven pulley as shown and secure the pulley (illustration A).

Extend the both valve rods until it stops lightly (the flap valves in high position) and tighten the lock nuts (illustration B).

Remove the bolt from the driven pulley.

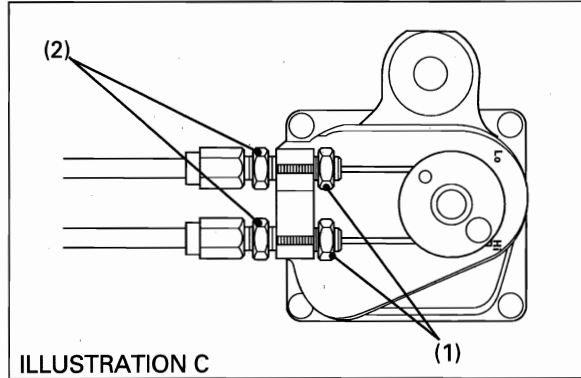

ILLUSTRATION C
(1) ADJUSTER NUTS (2) LOCK NUTS

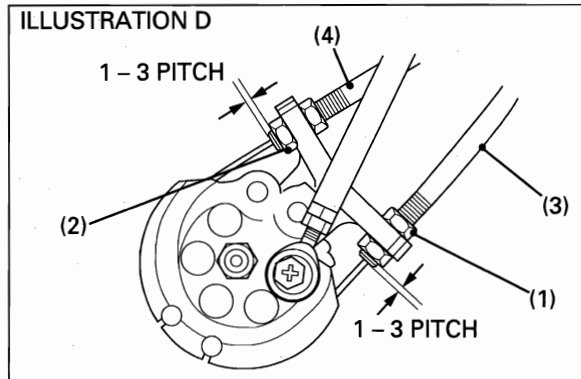

ILLUSTRATION D
(1) ADJUST NUTS (2) LOCK NUTS
(3) LOW CONTROL CABLE
(4) HI CONTROL CABLE

RC Valve Cable Adjustment

1. Disconnect the throttle sensor connector.
2. Loosen the lock nuts on the HI and LOW control cables (illustration C).
3. Adjust the cables as shown in the illustration D.
4. Tighten the lock nuts.
5. Connect the full charged 12 V battery (Red: +, Green: -).

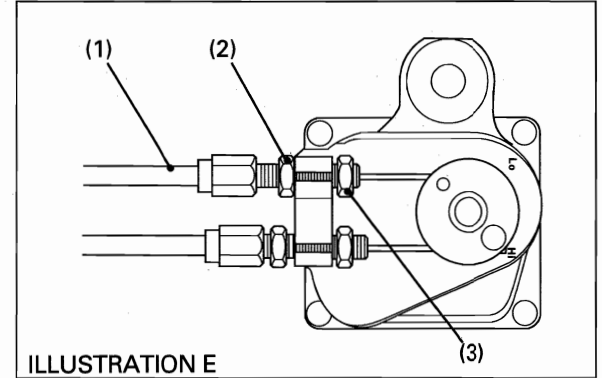

ILLUSTRATION E
(1) LOW CONTROL CABLE (2) ADJUSTER NUT
(3) LOCK NUT

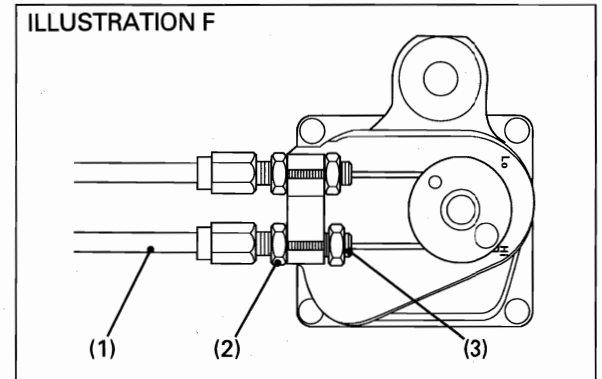
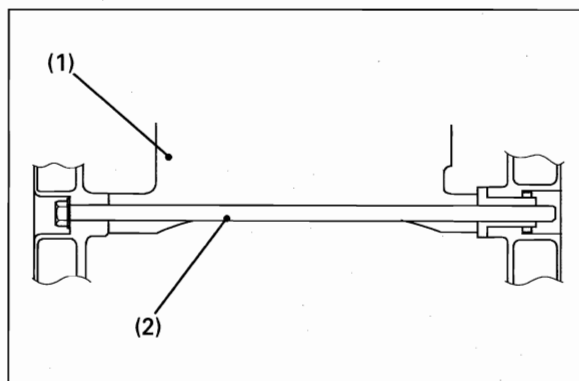

ILLUSTRATION F
(1) HI CONTROL CABLE (2) ADJUSTER NUT
(3) LOCK NUT

6. Turn the engine stop switch RUN.
7. Tighten the adjuster nut on the LOW control cable until the pulley starts to vibrate slightly, then turn the nut 1/2 turn past the point where the pulley starts vibrating. Tighten the lock securely (illustration E).
8. Tighten the adjuster nut on the HI control cable until the pulley stops to vibrate, then turn the nut 1/3 turn past the point where the pulley stops vibrating. Tighten the lock securely (illustration F).

9. Replace the fully charged 12 V battery if the servo motor does not operation or servo motor operation is incorrectly while the RC valve adjustment.



(1) ENGINE (2) UPPER HANGER BOLT

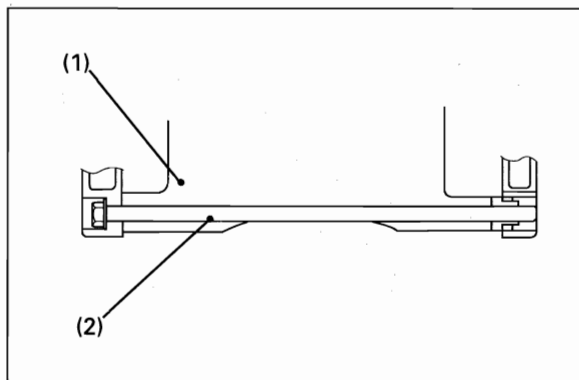

(1) ENGINE (2) LOWER HANGER BOLT

Engine Installation

Apply grease to the engine hanger adjusting bolt threads.

Use a floor jack or other adjustable support to carefully maneuver the engine into place.

Install the engine assembly.

Install the upper engine hanger bolt.

Install the lower engine hanger bolt.

Do not tighten the adjusting bolts yet.

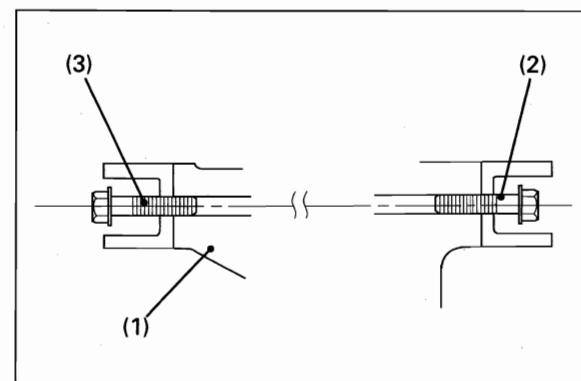

(1) ENGINE (2) RIGHT HANGER BOLT
(3) LEFT HANGER BOLT

Install the right engine hanger bolt.
Install the left engine hanger bolt.

Do not tighten the left and right hanger bolts yet.

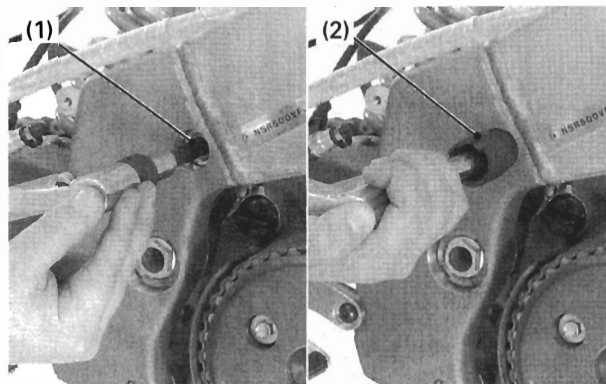

(1) ADJUSTING BOLT (2) LOCK NUT WRENCH

Use the left end of the hanger at the rear of the upper case as the base.

Adjust the clearance to zero (0) with the adjusting bolt on the right of the hanger at the rear of the upper side.

Tighten the adjusting bolt to specified torque.

Torque: 20 N·m (2.0 kg-m, 14 ft-lb)

Tighten the lock nut to specified torque.

TOOL:

Lock nut wrench, 20 × 24 mm 07716-0020100

Torque: 30 N·m (3.0 kg-m, 22 ft-lb)

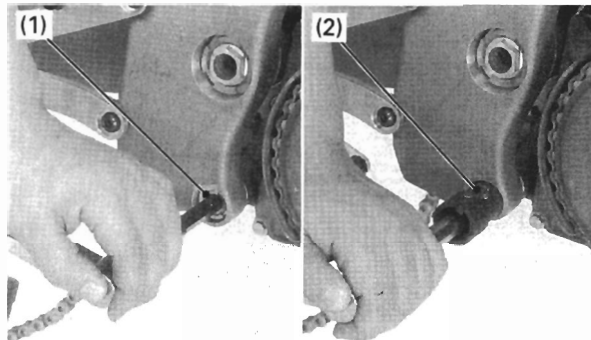

(1) ADJUSTING BOLT (2) LOCK NUT WRENCH

Adjust the clearance to zero (0) with the adjusting bolt on the right of the hanger at the rear of the lower side.

Tighten the adjusting bolt to specified torque.

Torque: 20 N·m (2.0 kg-m, 14 ft-lb)

Tighten the lock nut to specified torque.

TOOL:

Lock nut wrench, 20 × 24 mm 07716-0020100

Torque: 30 N·m (3.0 kg-m, 22 ft-lb)

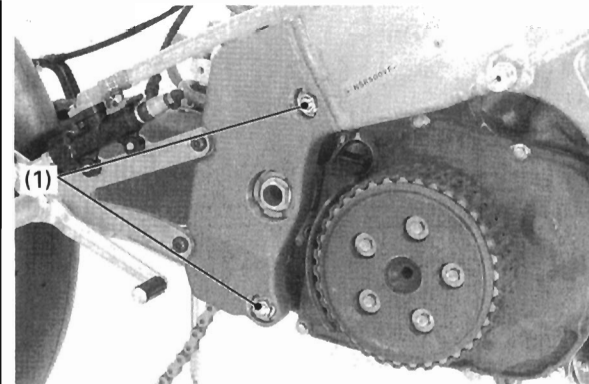

(1) HANGER NUTS

Tighten the upper engine hanger nut.

Torque: 40 N·m (4.0 kg-m, 29 ft-lb)

Tighten the lower engine hanger nut.

Torque: 40 N·m (4.0 kg-m, 29 ft-lb)

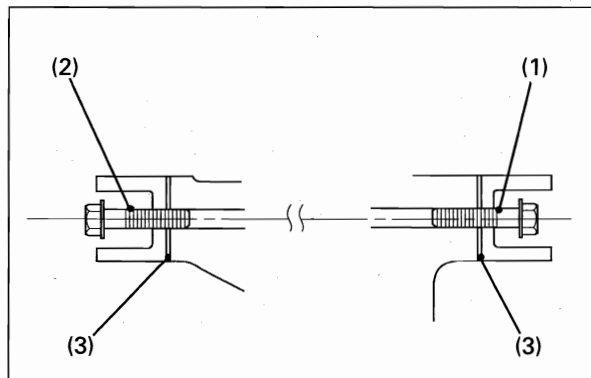

(1) RIGHT HANGER BOLT
 (2) LEFT HANGER BOLT
 (3) SHIM

Measure the clearance by inserting a feeler gauge between the right hanger on the crankcase and frame.

Measure the old shim thickness and adjust the clearance to zero (0) using shim.

Measure the clearance by inserting a feeler gauge between the left hanger on the crankcase and frame. Measure the old shim thickness and adjust the clearance to zero (0) using shim.

Engine mount shim:

- 0.2 mm: 90510-NX4-000
- 0.6 mm: 90511-NX4-000
- 1.0 mm: 90512-NX4-000
- 1.5 mm: 90513-NX4-000

Tighten the engine hanger bolts.

Torque: 40 N·m (4.0 kg-m, 29 ft-lb)

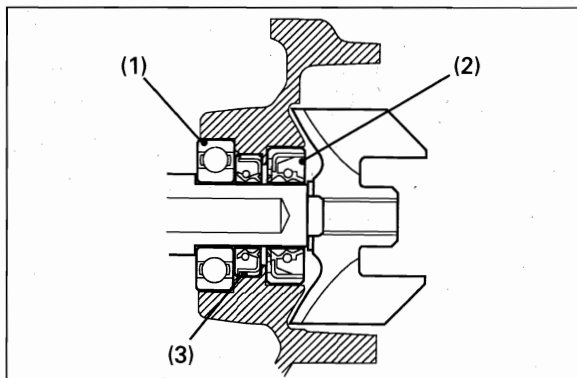

(1) BEARING (2) WATER SEAL (3) OIL SEAL

Water Pump

Water Seal/Oil Seal Replacement

Install a new water seal and oil seal in the direction shown in the illustration above.

Install the new water pump bearing.

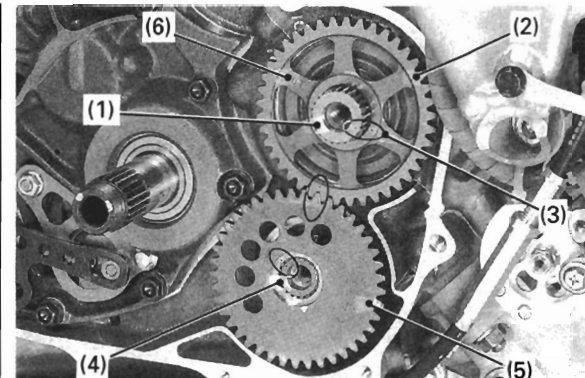

(1) CRANKSHAFT (2) BALANCER DRIVE GEAR
 (3) PUNCH MARKS (4) BALANCER SHAFT
 (5) BALANCER DRIVEN GEAR (6) OUT MARK

Balancer

NOTICE

The primary drive gear bolt has left hand threads.

Installation

Install the balancer shaft from the left side of the crankcase.

Install the balancer drive gear with its "OUT" mark facing out, aligning the punch marks on the balancer drive gear and crankshaft.

Install the balancer driven gear align the punch marks on the balancer driven gear and balancer shaft, between the balancer drive and driven gear.

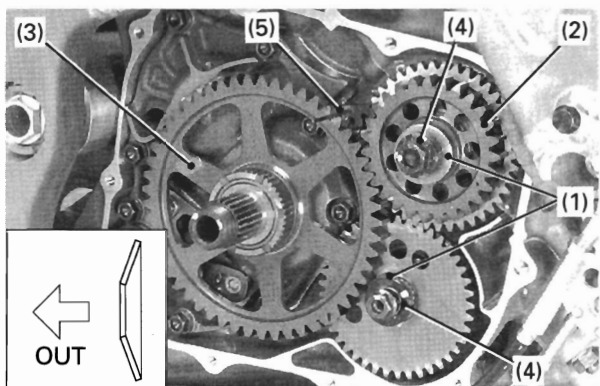

(1) WASHER (2) PRIMARY DRIVE GEAR
(3) PRIMARY DRIVEN GEAR (4) BOLT
(5) GEAR HOLDER

Install the washer onto the balancer shaft with the direction as shown.
Clean and apply a locking agent to the primary drive gear bolt threads and balancer driven gear bolt threads.

Install the following:

- Primary drive gear
- Washer
- Primary drive gear bolt with locking agent
- Balancer driven gear bolt with locking agent
- Primary driven gear guide
- Needle bearing
- Primary driven gear

Attach a gear holder between the balancer drive and driven gear.
Tighten the primary drive gear bolt and balancer driven gear bolt to the specified torque.

TOOL:

Gear holder 07724-0010100

Torque:

Primary drive gear bolt: 50 N·m (5.0 kg-m, 36 ft-lb)
Balancer driven gear bolt: 35 N·m (3.5 kg-m, 25 ft-lb)

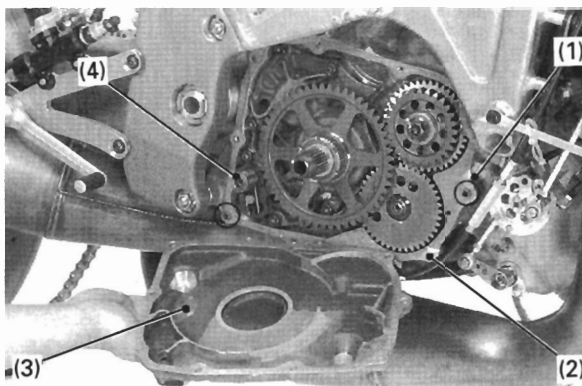

(1) DOWEL PINS (2) GASKET
(3) RIGHT CRANKCASE COVER (4) COLLAR

Install the dowel pins and a new gasket.
Install the gearshift spindle collar onto the gearshift spindle and right crankcase cover.
Install and tighten the bolts in a crisscross pattern in 2 or 3 steps.
Secure the oil drain bolt and filler cap using a lock wire.

Fill the transmission oil (Section 3).

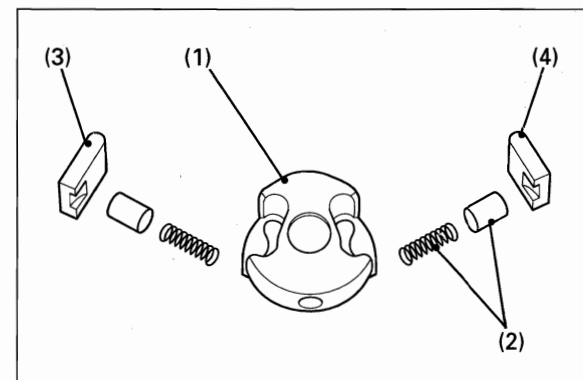

(1) DRUM SHIFTER (2) PLUNGERS/SPRINGS
(3) RATCHET PAWL A (4) RATCHET PAWL B

Drum Shifter

Assembly

Apply clean transmission oil to the ratchet pawls, springs and plungers.

Do not confuse the "A" and "B" ratchet pawls.

The ratchet pawl B is longer than pawl A.

Ratchet pawl A: L = 12.0 mm (0.47 in)

Ratchet pawl B: L = 12.75 mm (0.50 in)

Assemble the drum shifter, springs, plungers and ratchet pawls in the guide plate as shown.

Transmission Disassembly/Assembly

- Always install the thrust washers and snap rings with the chamfered (rolled) edge facing away from thrust load.
- After installing a snap ring, slightly open the ring and rotate it in its groove to be sure it is fully seated.
- Do not reuse the snap rings which could easily spin in the groove. They may be too loose to properly seat in groove. Align the gap in the snap ring with the spline groove.

Mainshaft:

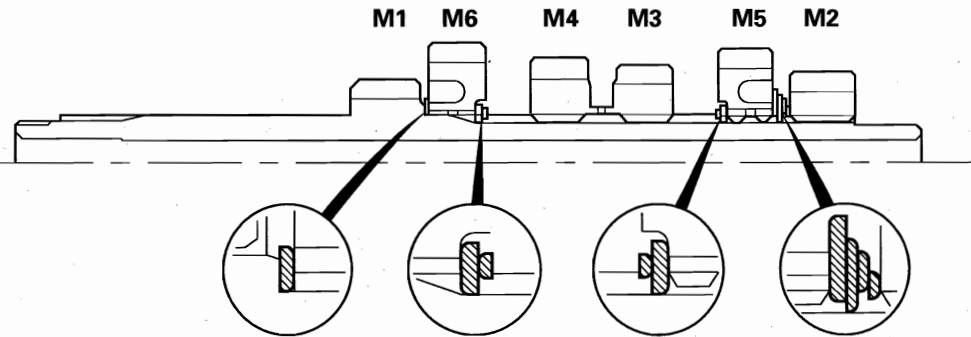

Countershaft:

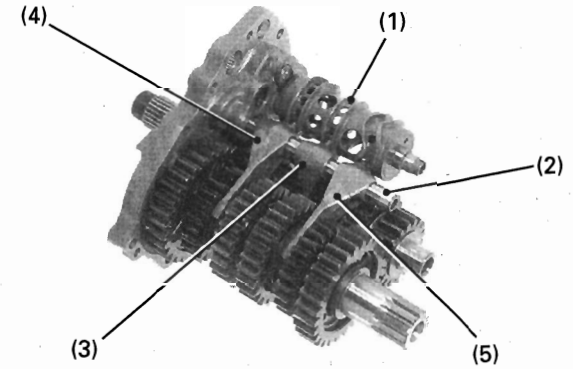
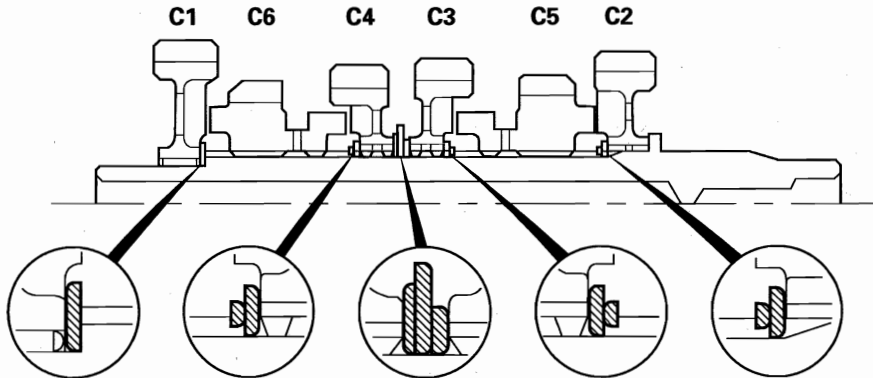

- (1) SHIFT DRUM (2) SHIFT FORK SHAFT
(3) CENTER SHIFT FORK (4) RIGHT SHIFT FORK
(5) LEFT SHIFT FORK

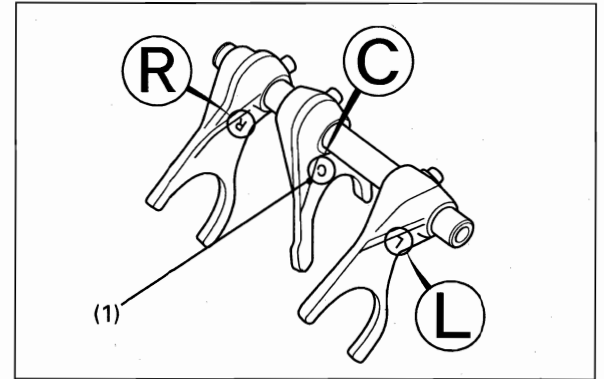

- (1) MARKS

Installation the shift drum.
Coat each gear with clean transmission oil and check for smooth movement.
Install the shift forks into the shifter gear grooves with its identification marks facing to reverse of the bearing holder.
Slide the shift fork shaft through the shift forks, and into the bearing holder.
After installation, check for smooth transmission operation.

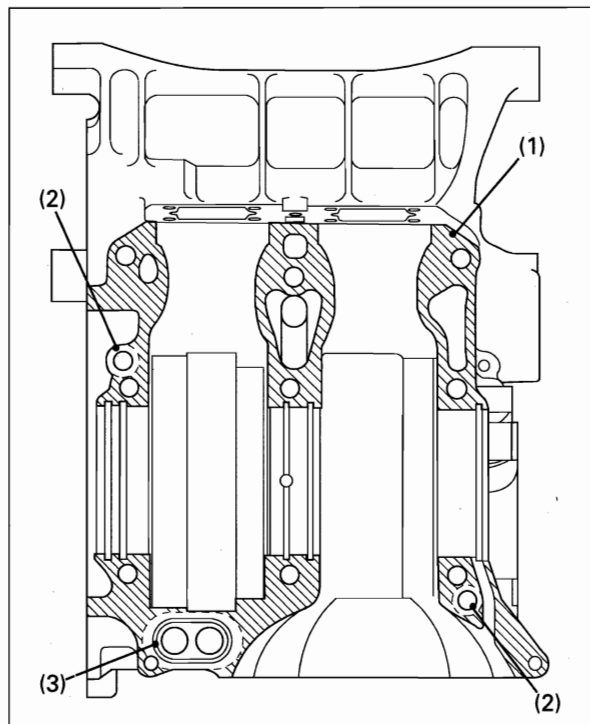

(1) LIQUID SEALANT APPLY AREA
(2) DOWEL PINS (3) O-RING

Crankcase Assembly

Clean the crankcase mating surfaces before assembling and check for wear or damage.

If there is minor roughness or irregularities on the crankcase mating surfaces, dress them with an oil stone.

Apply Three Bond 1207B or an equivalent commercially available liquid sealant to the mating surface of the lower crankcase as shown. Do not apply sealant into the dowel pin holes.

Install the dowel pins and new O-ring.

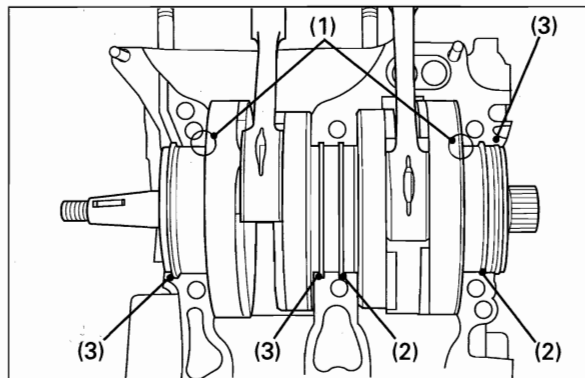

(1) DOWEL PINS (2) SET RINGS
(3) PROJECTIONS

Apply Three Bond 1207B or an equivalent commercially available liquid sealant to the outer surface of the crankshaft oil seals.

When installing the crankshaft, align the crankshaft bearing dowel pin and set ring with the groove of the lower crankcase.

Align the crankshaft oil seal projection with the groove of the lower crankcase.

Lubricate the crankshaft bearings with clean specified engine oil.

- Part No. for the liquid sealant: 88887-NX4-000

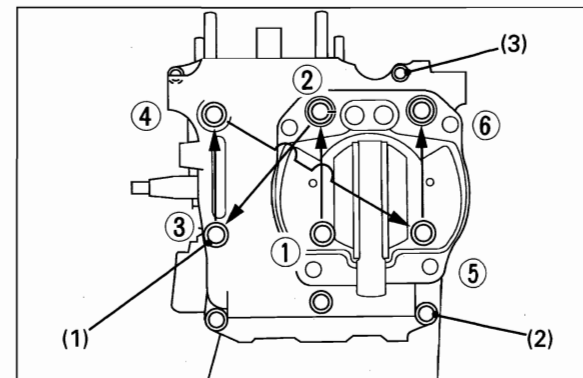

(1) 9 mm BOLTS (2) 8 mm BOLTS (3) NUTS

Place the upper crankcase onto the lower crankcase.

Apply engine oil to the 9 mm crankcase bolt threads. Apply engine oil to the 9 mm crankcase bolt washers. Install the 9 mm crankcase bolts and washers.

Refer to illustration for proper torque tightening sequence, such as the three steps; 10 N·m (1.0 kg-m, 7 ft-lb), 20 N·m (2.0 kg-m, 14 ft-lb) and 35 N·m (3.5 kg-m, 25 ft-lb).

Torque:
9 mm crankcase bolt: 35 N·m (3.5 kg-m, 25 ft-lb)

Install and tighten the 8 mm crankcase bolts and nuts in a crisscross pattern in 2 to 3 steps.

Torque:
8 mm crankcase bolt: 23 N·m (2.3 kg-m, 17 ft-lb)
6 mm nut: 12 N·m (1.2 kg-m, 9 ft-lb)

After installation, check the crankshaft turns smoothly. If you feel binding, disassemble and reassemble it again.

Memo

5. Frame Servicing

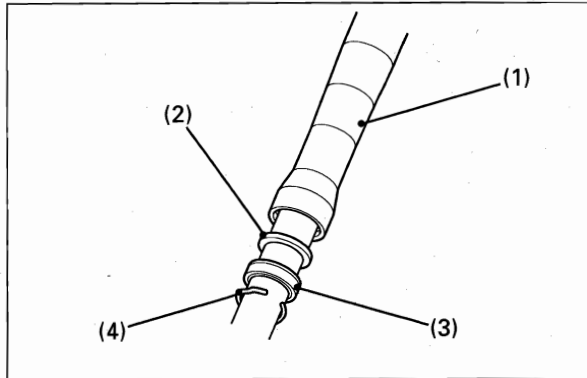

(1) OUTER TUBE (2) SEAL SPACER
(3) OIL SEAL (4) STOPPER RING

Fork Oil Seal Replacement

1. Remove the front fork.
2. Remove the stopper ring.
3. Remove the fork bolt and drain the fork fluid, then pull out the outer tube.
4. Pull out the oil seal using a commercially available oil seal remover or screw driver.
5. Replace the oil seal with new one.

NOTICE

- Apply grease on inner side of the seal.
- Check oil leak after replacement.

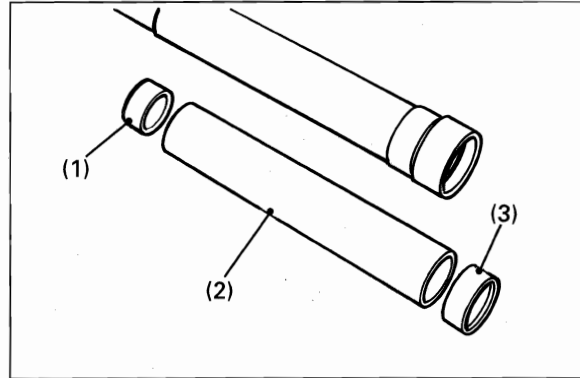

(1) GUIDE BUSHING B (2) DISTANCE COLLAR
(3) GUIDE BUSHING

Fork Guide Bushing Replacement

1. Push out the guide bushing B using a suitable pipe (Outer dia 45 mm).
2. Remove the guide bushing and distance collar.

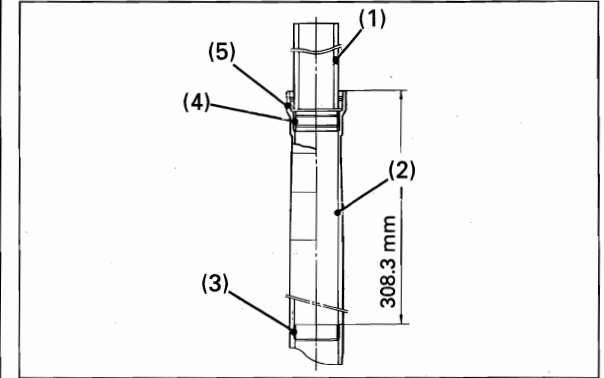

(1) PIPE (46 mm) (2) OUTER TUBE
(3) GUIDE BUSHING B (4) GUIDE BUSHING
(5) SEAL SPACER

3. Press in the guide bushing B using a suitable pipe (Outer dia 46 mm) after apply recommended fork fluid on it.
4. Press the guide bushing B in so that it is 308.3 mm below the outer tube.
5. Install the distance collar.
6. Press in the guide bushing with the seal spacer using a suitable pipe (Outer dia 46 mm).

NOTICE

Be careful not to scratch the teflon coating off the bushing.

To purchase the front fork and rear cushion parts or service and maintenance, consult a SHOWA EUROPE S.A.

SHOWA EUROPE S.A.

Mr. Antonio Jimenez
C/PRESSEGUERAR, S/N.
POLIGONO INDUSTRIAL MARTORELLES
08107 MARTORELLES (BARCELONA)
SPAIN

Tel. +34 (9) 3 / 570. 68. 58
Fax. +34 (9) 3 / 570. 54. 11

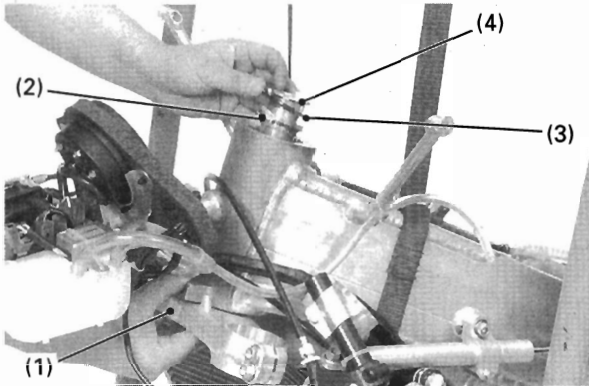

(1) STEERING STEM (2) UPPER INNER RACE
(3) DUST SEAL (4) BEARING ADJUSTING NUT

Steering Stem Installation

Apply grease to the upper and lower bearings and races.

Slide the steering stem through the steering head from the bottom.

Install the upper bearing and dust seal.

Apply oil to the stem bearing adjusting nut threads.

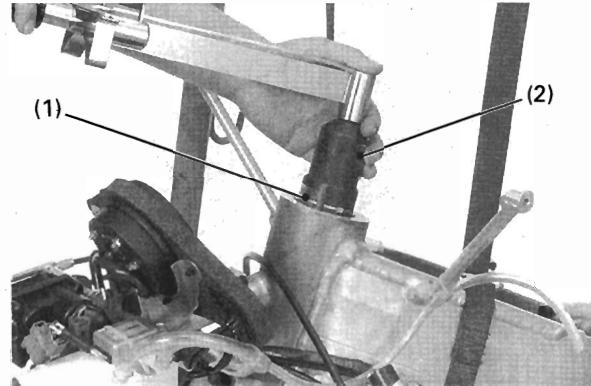

(1) BEARING ADJUSTING NUT
(2) STEERING STEM SOCKET

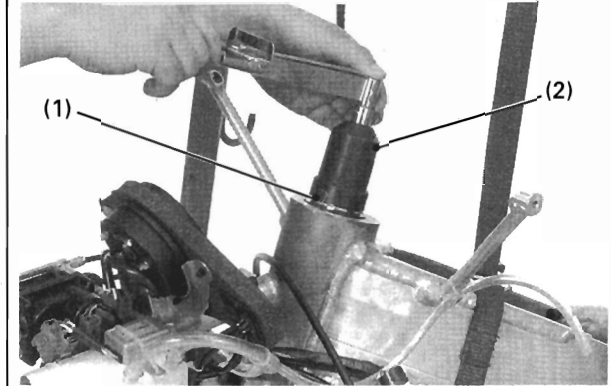

(1) BEARING ADJUSTING NUT
(2) STEERING STEM SOCKET

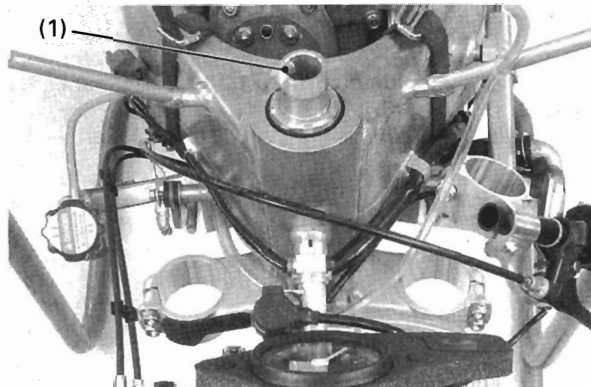

(1) STEERING STEM

Tighten the adjusting nut to the specified torque using the special tool.

TOOL:
Steering stem socket **07HMA-MR70100**

Torque: 20 N·m (2.0 kg-m, 14 ft-lb)

Move the steering stem right and left, lock-to-lock several times to seat the bearings.

Make sure that the steering stem moves smoothly, without play or binding.

Loosen the bearing adjusting nut, so that the nut turns by hand.
Do not loosen the nut more than necessary.

Retighten the stem bearing adjusting nut to the specified torque using the special tool.

TOOL:
Steering stem socket **07HMA-MR70100**

Torque: 4 N·m (0.4 kg-m, 2.9 ft-lb)

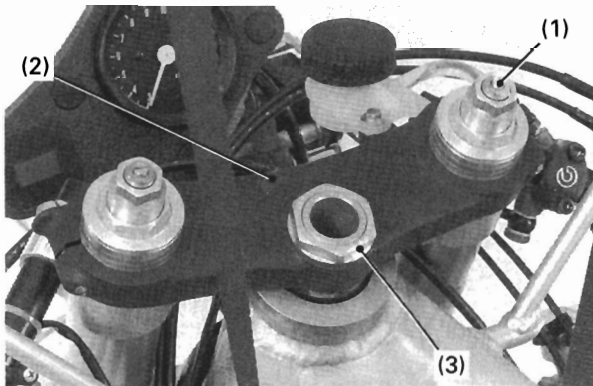

(1) FORK LEGS (2) TOP BRIDGE
(3) STEM NUT

Install the following:

- Fork legs
- Handlebar
- Top bridge

Apply oil to the steering stem nut threads.
Install and tighten the steering stem nut to the specified torque.

Torque: 60 N·m (6.0 kg·m, 43 ft·lb)

Install the front wheel and upper cowl.



(1) LOCK PIN (2) STOPPER (3) REAR WHEEL
(4) WHEEL NUT (LEFT-HAND THREADS)

Rear Wheel

To purchase the wheel or service, consult a RUOTE MARCHESINI S.r.l.

RUOTE MARCHESINI S.r.l.
Mrs. Silvia Marchesini
V. Beata Giuliana, 5
21010 VERGHERA DI SAMARATE (VA)
ITALY

Tel. +39 (0) 331 / 22. 41. 81
Fax. +39 (0) 331 / 22. 31. 62

Removal

Support the machine using the maintenance stand and install the stopper.

Remove the lock pin and loosen the wheel nut.

NOTICE

The wheel nut has left-hand threads.

Remove the rear axle nut and rear wheel.

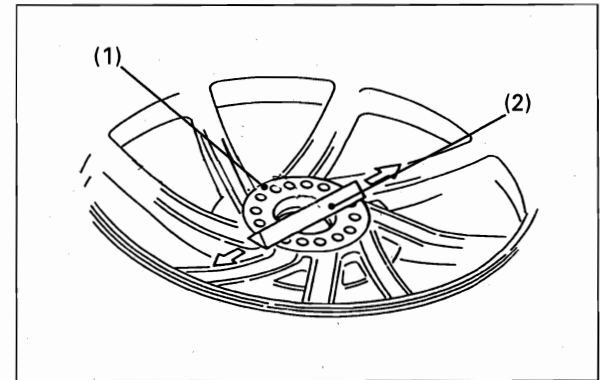

(1) DRIVE PIN HOLES (2) OIL STONE

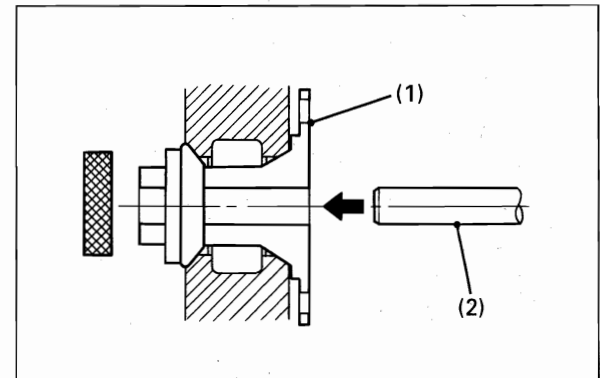

(1) WHEEL BALANCE ATTACHMENT
(2) 20 mm O.D. SHAFT

Inspection

Check the drive pin holes for wear, cracks or damage. Always clean the axle hub mating surface of the wheel using a fine oil stone.

Wheel Balance

Place the rear wheel in an inspection stand using the special tool.

TOOL:

Wheel balance attachment KFL-50-3-N

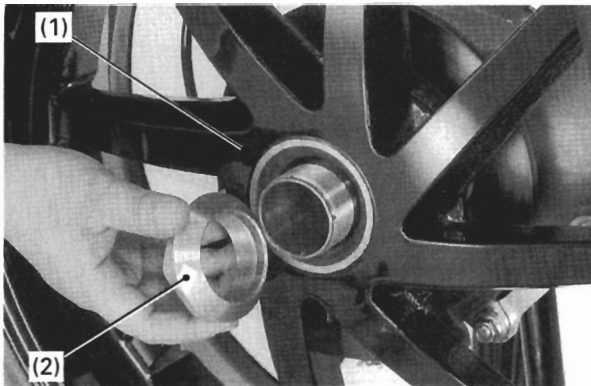

(1) REAR WHEEL
(2) WHEEL NUT (LEFT-HAND THREADS)

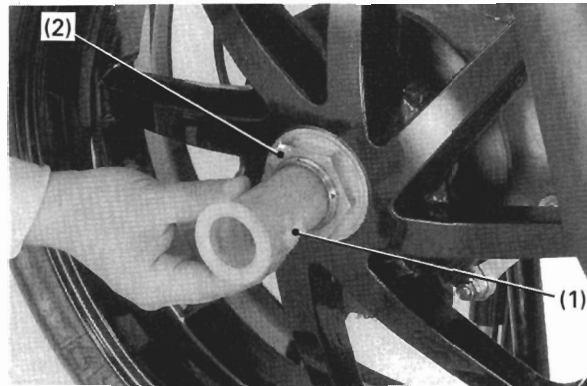

(1) STAND SET COLLAR
(2) WHEEL NUT (LEFT-HAND THREADS)

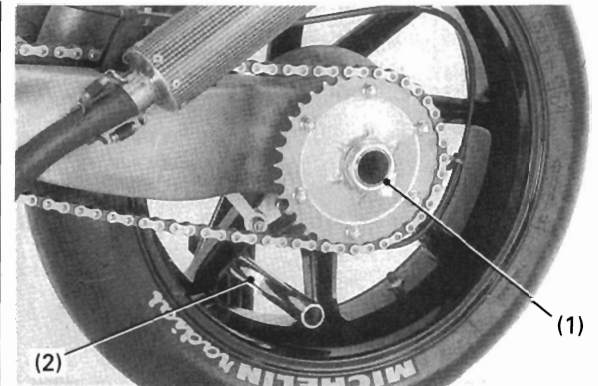

(1) AXLE NUT (2) STOPPER



(1) LOCK PIN (2) STOPPER

Rear Axle/Eccentric Body

Removal

Loosen the eccentric body pinch bolts and make a drive chain slack fully (page 3-4).

Loosen the wheel nut (page 5-3), then install the stand set collar.

Make the stand set collar by yourself refer to the illustration below.

Material: Nylon

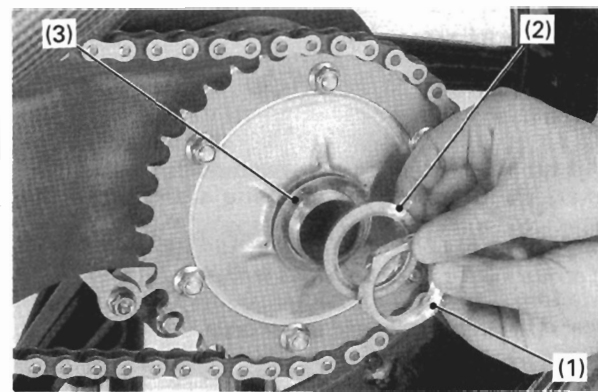
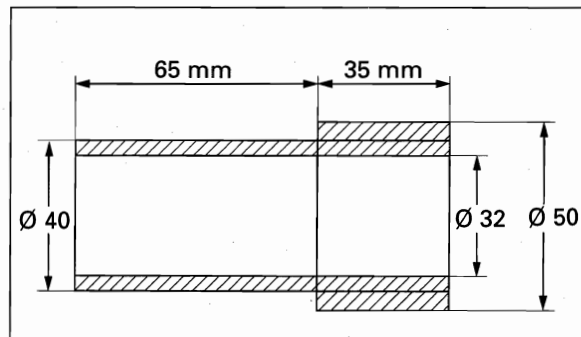

(1) AXLE NUT (2) CONICAL WASHER
(3) SHIM

Installation

Install the rear wheel aligning the holes with the rear axle drive pin.
Apply grease to the wheel nut threads and seating surface.
Tighten the wheel nut to the specified torque.

Torque: 280 N·m (28.0 kg-m, 202 ft-lb)

Install the lock pin.

Support the machine using the maintenance stand and install the stopper.

Remove the lock wire and loosen the axle nut.

Remove the rear axle nut, conical washer and shim.

Installation

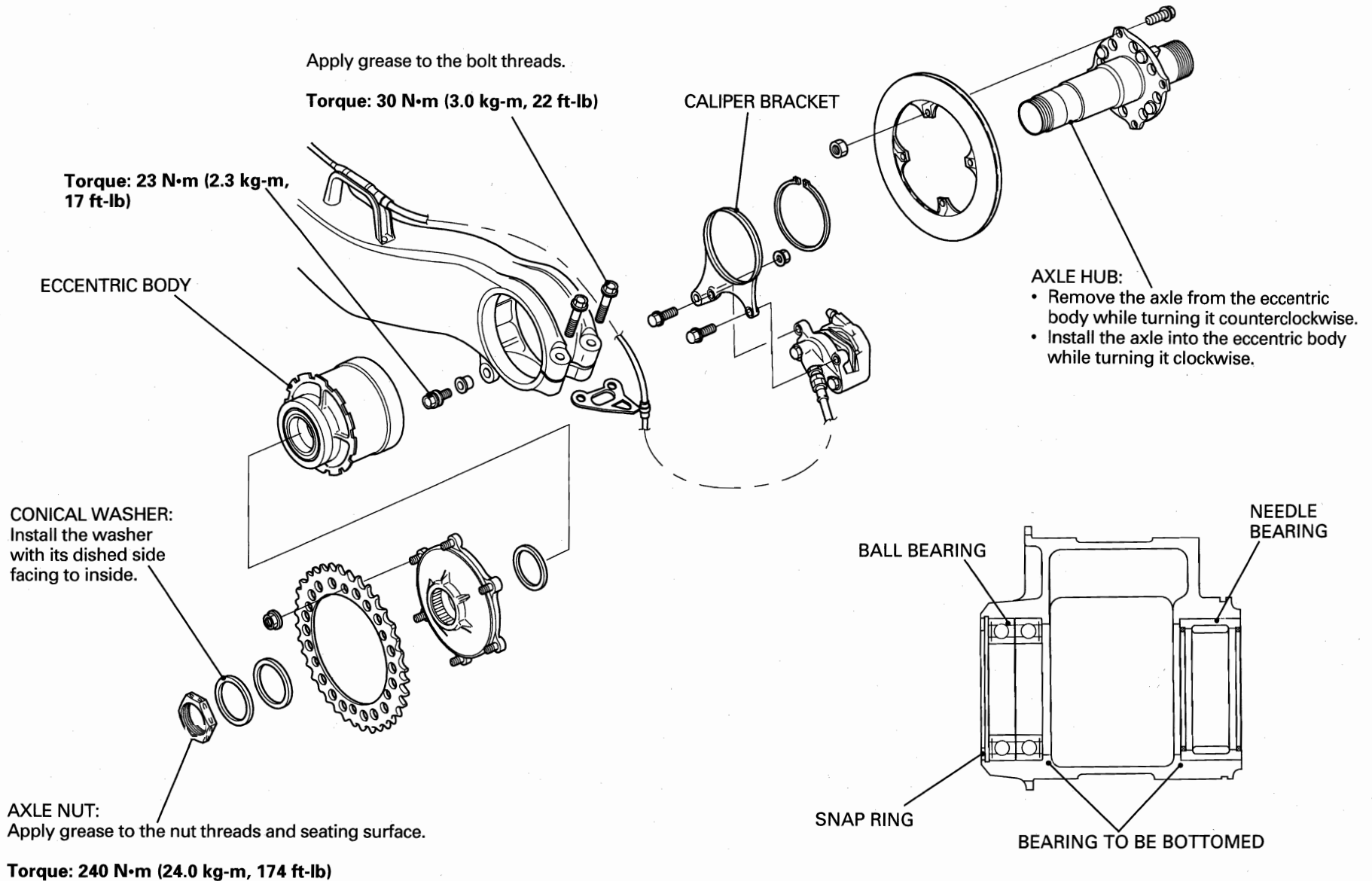

Memo

(

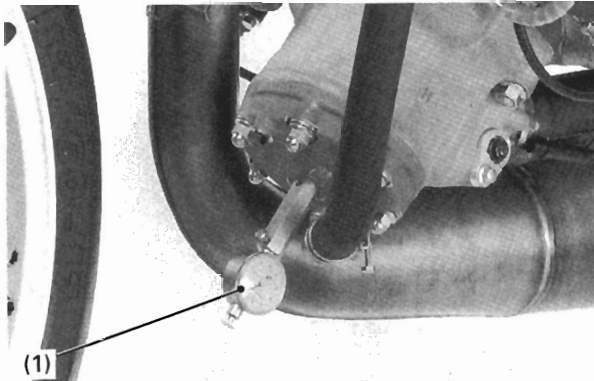

(1) TOP GAUGE

Ignition Timing Adjustment

Inspection

- Your machine's exhaust contains poisonous carbon monoxide gas. High levels of carbon monoxide can collect rapidly in enclosed areas such as a garage. Do not run the engine with the garage door enclosed. Even with the door open, run the engine only long enough to move your machine out of the garage.
- The CDI unit system is factory pre-set so that ignition timing inspection is not necessary.

- Place the #1 piston (front cylinder) at TDC using the dial gauge.

TOOL:

Top gauge set

07542-400-000

To purchase the " Top gauge set ", consult HRC - JAPAN/EUROPE.

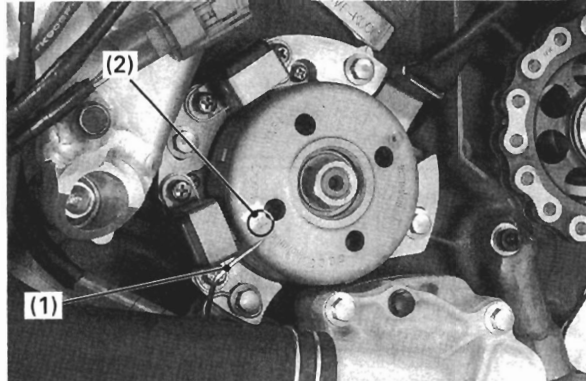

(1) WIRE (2) T1 MARK

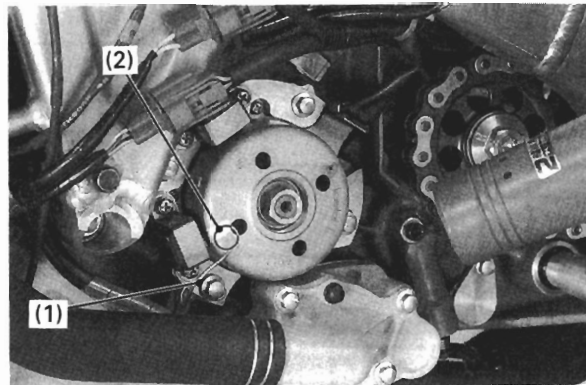

(1) WIRE (2) T1 MARK

- Attach a piece of wire to crankcase as a pointer and align it to the T1 mark on the AC generator rotor.
- Connect the timing light. Start the engine and warm it up to operating temperature.

Check for ignition timing using a timing light.

Ignition timing (#1, 2): $27.5^\circ \pm 1^\circ / 3,000 \text{ min}^{-1} \text{ (rpm)}$

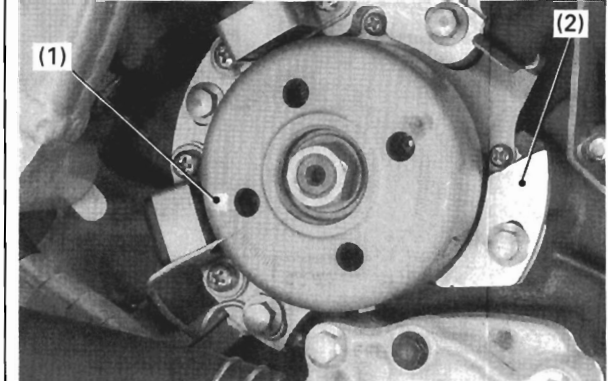

(1) T1 MARK (2) STATOR

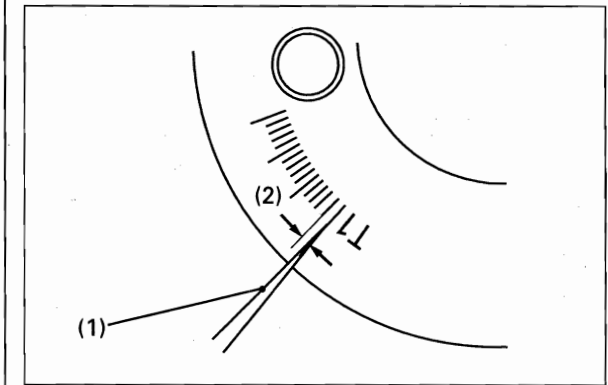

(1) WIRE (2) 2°

Adjustment

- If the ignition timing is not correct, scribe a mark on the crankcase to indicate where the timing mark is in relation to the pointer. Recode the angle and distance.
- Loosen the stator mount bolts. Rotate the stator in the opposite direction the same angle and distance as you recorded above.
- Tighten the stator mount bolts and recheck the ignition timing.



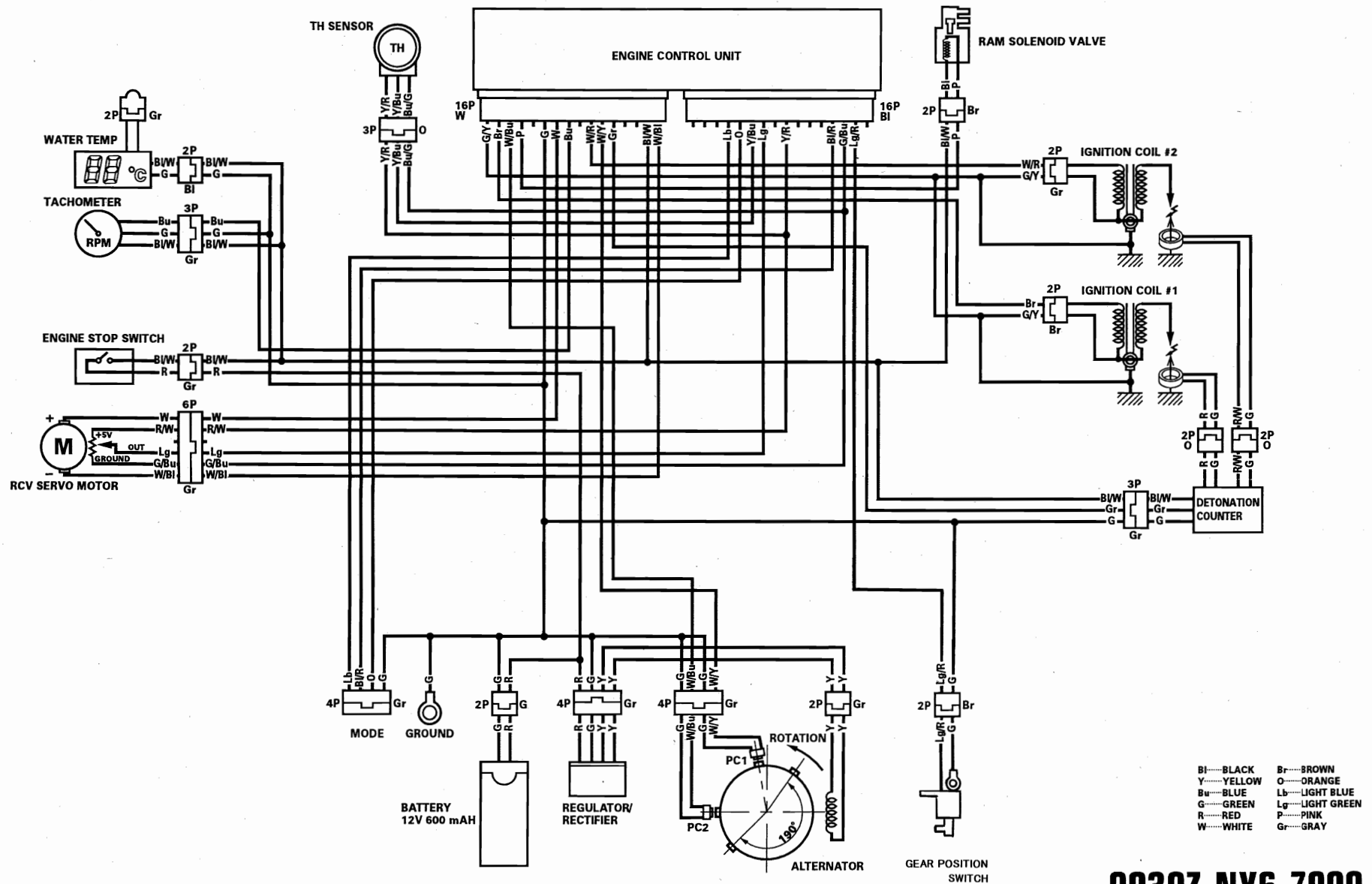

Electrical Servicing

Wiring Diagram

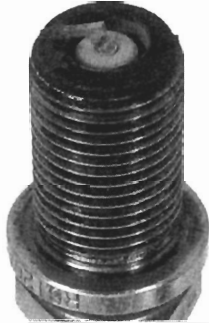

0030Z-NX6-7000

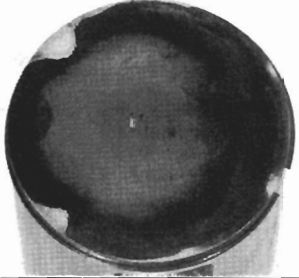
7. Machine Settings

<p>Burn condition</p>			
			
<p>Standards for determining the burn condition</p>	<p>Over rich: engine setting is incorrect</p>	<p>Good</p>	<p>Overburned; engine setting is incorrect (lean mixture)</p>
<p>Gasoline type</p>	<p>Premium unleaded gasoline (research octane number of 100 or higher)</p>		

Appraisal Of The Burn Condition: Premium unleaded gasoline

Piston head and spark plug burn condition varies according to several conditions, engine performance, course type, running distance, fuel, oil and weather. Also, the burn condition is in a state of constant flux according to conditions so it will vary depending on when the plug is removed. When looking at the head's and plug's burn condition, it may be an oversimplification to conclude that it is overburned because is white, or sooty because it is black. Such conclusions are not always justified. If you misjudge, not only will your time be poor, it may actually cause engine trouble and force you to retire from the race.

How to ascertain the unleaded gasoline's burn condition

The burn condition is determined from both the piston head and spark plug.

- * Piston head: Check the coloration and detonation.
- * Insulator: Check the coloration.
- * Ground electrode: Check the dimensions of the portion that is burned white.

Also, the burn condition refers to the condition immediately before the engine was stopped, so you must check the burn condition by turning the engine off while running with the throttle wide open and then gliding into the pit stop through inertia.

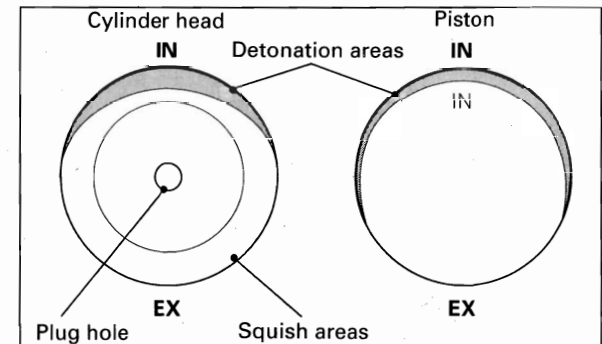

Machine Settings

Optional Transmission Gears

Optional transmission gears are available for use in the transmission. Care should be taken when substituting optional gears for the standard gears. The optional low gear/mainshaft has marking etched on the shaft end for identification. Identification for other gears is aided by a marking located on the side of the gear.

Gears		Marking And Parts Number				No. of Teeth		Ratio	
		Main		Counter		M	C		
1st	OP	1 LINE	23211-NX6-000	C1-P1	23411-NX6-000	15	32	2.133	
	OP	1 LINE	23211-NX6-000	C1-P2	23412-NX6-000	15	31	2.067	
	STD	1 LINE	23211-NX6-000	C1-P3	23413-NX6-000	15	30	2.000	
	OP	2 LINES	23212-NX6-000	C1-P4	23414-NX6-000	16	31	1.938	
	OP	2 LINES	23212-NX6-000	C1-P5	23415-NX6-000	16	30	1.875	
2nd	OP	M2-P1	23421-NX6-000	C2-P1	23431-NX6-000	17	30	1.765	
	OP	M2-P2	23422-NX6-000	C2-P2	23432-NX6-000	17	29	1.706	
	OP	M2-P2	23422-NX6-000	C2-P3	23433-NX6-000	17	28	1.647	
	OP	M2-P3	23423-NX6-000	C2-P2	23432-NX6-000	18	29	1.611	
	STD	M2-P4	23424-NX6-000	C2-P3	23433-NX6-000	18	28	1.556	
	OP	M2-P5	23425-NX6-000	C2-P4	23434-NX6-000	18	27	1.500	
3rd/4th	OP	M34-P1	23441-NX6-010	3rd	C3-P1	23451-NX6-700	18	28	1.556
					C3-P2	23452-NX6-700	18	27	1.500
				4th	C4-P1 C3-P5	23455-NX6-700	20	27	1.350
					C4-P2 C3-P6	23456-NX6-700	20	26	1.300
	OP	M34-P2	23442-NX6-010	3rd	C3-P1	23451-NX6-700	18	28	1.556
					C3-P2	23452-NX6-700	18	27	1.500
				4th	C4-P3	23473-NX6-700	21	26	1.238
					C4-P4	23474-NX6-700	21	25	1.190
	OP	M34-P3	23443-NX6-010	3rd	C3-P1	23451-NX6-700	18	28	1.556
					C3-P2	23452-NX6-700	18	27	1.500
	OP	M34-P4	23444-NX6-010	4th	C4-P5	23475-NX6-700	21	24	1.143
				3rd	C3-P3	23453-NX6-700	19	28	1.474
					C3-P4	23454-NX6-700	19	27	1.421
					C4-P1 C3-P5	23455-NX6-700	20	27	1.350
	OP	M34-P5	23445-NX6-010		C4-P2 C3-P6	23456-NX6-700	20	26	1.300
				3rd	C3-P3	23453-NX6-700	19	28	1.474
					C3-P4	23454-NX6-700	19	27	1.421
					C4-P3	23473-NX6-700	21	26	1.238
	OP	M34-P6	23446-NX6-010		C4-P4	23474-NX6-700	21	25	1.190
				3rd	C3-P3	23453-NX6-700	19	28	1.474
					C3-P4	23454-NX6-700	19	27	1.421
					C4-P5	23475-NX6-700	21	24	1.143
	STD	M34-P7	23447-NX6-010	3rd	C3-P5 C4-P1	23455-NX6-700 (OP)	20	27	1.350
						C3-P6 C4-P2	23456-NX6-700 (STD)	20	26
4th				C4-P3	23473-NX6-700 (OP)	21	26	1.238	
				C4-P4	23474-NX6-700 (STD)	21	25	1.190	
OP	M34-P8	23448-NX6-010	3rd	C3-P5 C4-P1	23455-NX6-700	20	27	1.350	
					C3-P6 C4-P2	23456-NX6-700	20	26	1.300
			4th	C4-P5	23475-NX6-700	21	24	1.143	
5th	OP	M5-P1	23481-NX6-010	C5-P1	23491-NX6-700	21	25	1.190	
	OP	M5-P1	23481-NX6-010	C5-P2	23492-NX6-700	21	24	1.143	
	STD	M5-P3 M6-P1	23483-NX6-010	C5-P3 C6-P1	23493-NX6-700	22	24	1.091	
	OP	M5-P3 M6-P1	23483-NX6-010	C5-P4 C6-P2	23494-NX6-700	22	23	1.045	
	OP	M5-P4 M6-P3	23484-NX6-010	C5-P4 C6-P2	23494-NX6-700	23	23	1.000	
6th	OP	M6-P1 M5-P3	23483-NX6-010	C6-P1 C5-P3	23493-NX6-700	22	24	1.091	
	OP	M6-P1 M5-P3	23483-NX6-010	C6-P2 C5-P4	23494-NX6-700	22	23	1.045	
	OP	M6-P3 M5-P4	23484-NX6-010	C6-P2 C5-P4	23494-NX6-700	23	23	1.000	
	STD	M6-P4	23504-NX6-010	C6-P4	23514-NX6-700	23	22	0.957	
	OP	M6-P5	23505-NX6-010		C6-P4	23514-NX6-700	24	22	0.917

Speed List (10,000 rpm) Primary reduction: 27/52 Tire: R=315 mm

Gears	No. of Teeth		Gear ratio	15	15	15	16	15	16	15	16	17	15	16	17	16	17	16	17	17	17	Drive
	M	C		40	39	38	40	37	39	36	38	40	35	37	39	36	38	35	37	36	35	
1st	15	32	2.133	108	111	114	116	117	119	120	122	123	124	125	126	128	129	132	133	137	140	
	15	31	2.067	112	115	118	119	121	122	124	126	127	128	129	130	133	133	136	137	141	145	
	15	30	2	116	119	122	123	125	126	128	130	131	132	133	134	137	138	141	142	146	150	
	16	31	1.938	119	122	126	127	129	131	133	134	135	136	138	139	141	142	145	146	150	155	
	16	30	1.875	123	126	130	132	133	135	137	138	140	141	142	143	146	147	150	151	155	160	
2nd	17	30	1.765	131	134	138	140	142	143	146	147	148	150	151	152	155	156	160	161	165	170	
	17	29	1.706	136	139	143	145	147	148	151	152	154	155	156	158	161	162	165	166	171	176	
	17	28	1.647	140	144	148	150	152	154	156	158	159	160	162	163	166	167	171	172	177	182	
	18	29	1.611	144	147	151	153	155	157	159	161	163	164	166	167	170	171	175	176	181	186	
	18	28	1.556	149	152	156	159	161	163	165	167	168	170	171	173	176	177	181	182	187	192	
	18	27	1.5	154	158	162	164	167	169	171	173	175	176	178	179	183	184	188	189	194	200	
3rd	18	28	1.556	149	152	156	159	161	163	165	167	168	170	171	173	176	177	181	182	187	192	
	18	27	1.5	154	158	162	164	167	169	171	173	175	176	178	179	183	184	188	189	194	200	
	19	28	1.474	157	161	165	167	170	172	174	176	178	179	181	182	186	187	191	192	198	203	
	19	27	1.421	163	167	171	174	176	178	181	183	184	186	188	189	193	194	198	199	205	211	
	20	27	1.35	171	176	180	183	185	187	190	192	194	196	198	199	203	204	209	210	216	222	
	20	26	1.3	178	182	187	190	192	195	198	200	202	203	205	207	211	212	217	218	224	230	
4th	20	27	1.35	171	176	180	183	185	187	190	192	194	196	198	199	203	204	209	210	216	222	
	20	26	1.3	178	182	187	190	192	195	198	200	202	203	205	207	211	212	217	218	224	230	
	21	26	1.238	187	192	197	199	202	204	208	210	212	213	215	217	221	223	228	229	235	242	
	21	25	1.19	194	199	205	207	210	213	216	218	220	222	224	226	230	232	237	238	245	252	
	21	24	1.143	202	207	213	216	219	221	225	227	229	231	233	235	240	241	247	248	255	262	
5th	21	25	1.19	194	199	205	207	210	213	216	218	220	222	224	226	230	232	237	238	245	252	
	21	24	1.143	202	207	213	216	219	221	225	227	229	231	233	235	240	241	247	248	255	262	
	22	24	1.091	212	217	223	226	229	232	235	238	240	242	244	246	251	253	258	260	267	275	
	22	23	1.045	221	227	233	236	239	242	246	248	251	253	255	257	262	264	270	271	279	287	
	23	23	1	231	237	243	247	250	253	257	260	262	264	267	269	274	276	282	283	291	299	
6th	22	24	1.091	212	217	223	226	229	232	235	238	240	242	244	246	251	253	258	260	267	275	
	22	23	1.045	221	227	233	236	239	242	246	248	251	253	255	257	262	264	270	271	279	287	
	23	23	1	231	237	243	247	250	253	257	260	262	264	267	269	274	276	282	283	291	299	
	23	22	0.957	242	248	254	258	261	264	268	271	274	276	279	281	286	288	295	296	304	313	
	24	22	0.917	252	259	265	269	273	276	280	283	286	288	291	293	299	301	307	309	318	327	
			2.667	2.6	2.533	2.5	2.467	2.438	2.4	2.375	2.353	2.333	2.313	2.294	2.25	2.235	2.188	2.176	2.118	2.059	Final ratio	

Machine Settings

Speed List (10,000 rpm) Primary reduction: 27/53 Tire: R=315 mm

Gears	No. of Teeth		Gear ratio	15	15	15	16	15	16	15	16	17	15	16	17	16	17	16	17	17	17	Drive
	M	C		40	39	38	40	37	39	36	38	40	35	37	39	36	38	35	37	36	35	
1st	15	32	2.133	106	109	112	113	115	116	118	119	121	122	123	124	126	127	130	130	134	138	
	15	31	2.067	110	113	116	117	119	120	122	123	124	125	127	128	130	131	134	134	138	142	
	15	30	2	113	116	119	121	123	124	126	127	129	130	131	132	134	135	138	139	143	147	
	16	31	1.938	117	120	123	125	127	128	130	131	133	134	135	136	139	140	143	143	147	152	
	16	30	1.875	121	124	127	129	131	132	134	136	137	138	140	141	143	144	147	148	152	157	
2nd	17	30	1.765	129	132	135	137	139	141	143	144	146	147	148	149	152	153	157	157	162	166	
	17	29	1.706	133	136	140	142	144	145	148	149	151	152	153	155	158	159	162	163	167	172	
	17	28	1.647	138	141	145	147	149	151	153	155	156	157	159	160	163	164	168	169	173	178	
	18	29	1.611	141	144	148	150	152	154	156	158	160	161	162	164	167	168	172	173	177	182	
	18	28	1.556	146	150	153	156	158	160	162	164	165	167	168	169	173	174	178	179	184	189	
	18	27	1.5	151	155	159	161	164	165	168	170	171	173	174	176	179	180	184	185	190	196	
3rd	18	28	1.556	146	150	153	156	158	160	162	164	165	167	168	169	173	174	178	179	184	189	
	18	27	1.5	151	155	159	161	164	165	168	170	171	173	174	176	179	180	184	185	190	196	
	19	28	1.474	154	158	162	164	166	168	171	173	174	176	177	179	182	184	188	189	194	199	
	19	27	1.421	160	164	168	170	173	175	177	179	181	182	184	186	189	190	195	196	201	207	
	20	27	1.35	168	172	177	179	182	184	187	189	190	192	194	195	199	200	205	206	212	218	
	20	26	1.3	175	179	184	186	189	191	194	196	198	199	201	203	207	208	213	214	220	226	
4th	20	27	1.35	168	172	177	179	182	184	187	189	190	192	194	195	199	200	205	206	212	218	
	20	26	1.3	175	179	184	186	189	191	194	196	198	199	201	203	207	208	213	214	220	226	
	21	26	1.238	183	188	193	195	198	200	204	206	208	209	211	213	217	219	223	225	231	237	
	21	25	1.19	191	196	201	203	206	209	212	214	216	218	220	222	226	227	232	234	240	247	
	21	24	1.143	198	204	209	212	215	217	221	223	225	227	229	231	235	237	242	243	250	257	
5th	21	25	1.19	191	196	201	203	206	209	212	214	216	218	220	222	226	227	232	234	240	247	
	21	24	1.143	198	204	209	212	215	217	221	223	225	227	229	231	235	237	242	243	250	257	
	22	24	1.091	208	213	219	222	225	227	231	233	236	238	240	242	246	248	253	255	262	269	
	22	23	1.045	217	223	229	232	235	238	241	244	246	248	250	252	257	259	265	266	273	281	
	23	23	1	227	233	239	242	245	248	252	255	257	259	262	264	269	271	277	278	286	294	
6th	22	24	1.091	208	213	219	222	225	227	231	233	236	238	240	242	246	248	253	255	262	269	
	22	23	1.045	217	223	229	232	235	238	241	244	246	248	250	252	257	259	265	266	273	281	
	23	23	1	227	233	239	242	245	248	252	255	257	259	262	264	269	271	277	278	286	294	
	23	22	0.957	237	243	250	253	256	259	263	266	269	271	273	276	281	283	289	290	299	307	
	24	22	0.917	247	254	260	264	267	271	275	278	280	283	285	288	293	295	302	303	312	320	
			2.667	2.6	2.533	2.5	2.467	2.438	2.4	2.375	2.353	2.333	2.313	2.294	2.25	2.235	2.188	2.176	2.118	2.059	Final ratio	

Speed List (10,000 rpm) Primary reduction: 27/54 Tire: R=315 mm

Gears	No. of Teeth		Gear ratio	15	15	15	16	15	16	15	16	17	15	16	17	16	17	16	17	17	17	Drive
	M	C		40	39	38	40	37	39	36	38	40	35	37	39	36	38	35	37	36	35	35
1st	15	32	2.133	104	107	110	111	113	114	116	117	118	119	120	121	124	125	127	128	131	135	
	15	31	2.067	108	110	113	115	116	118	120	121	122	123	124	125	128	129	131	132	136	140	
	15	30	2	111	114	117	119	120	122	124	125	126	127	128	129	132	133	136	136	140	144	
	16	31	1.938	115	118	121	123	124	126	128	129	130	131	132	134	136	137	140	141	145	149	
	16	30	1.875	119	122	125	127	128	130	132	133	135	136	137	138	141	142	145	145	150	154	
2nd	17	30	1.765	126	129	133	135	136	138	140	142	143	144	145	147	150	150	154	155	159	163	
	17	29	1.706	131	134	137	139	141	143	145	147	148	149	151	152	155	156	159	160	164	169	
	17	28	1.647	135	139	142	144	146	148	150	152	153	155	156	157	160	161	165	166	170	175	
	18	29	1.611	138	142	145	147	149	151	154	155	157	158	159	161	164	165	168	169	174	179	
	18	28	1.556	143	147	151	153	155	157	159	161	162	164	165	166	170	171	174	175	180	185	
	18	27	1.5	148	152	156	158	160	162	165	167	168	170	171	173	176	177	181	182	187	192	
3rd	18	28	1.556	143	147	151	153	155	157	159	161	162	164	165	166	170	171	174	175	180	185	
	18	27	1.5	148	152	156	158	160	162	165	167	168	170	171	173	176	177	181	182	187	192	
	19	28	1.474	151	155	159	161	163	165	168	170	171	173	174	176	179	180	184	185	190	196	
	19	27	1.421	157	161	165	167	169	171	174	176	178	179	181	182	186	187	191	192	197	203	
	20	27	1.35	165	169	174	176	178	180	183	185	187	188	190	192	195	197	201	202	208	214	
	20	26	1.3	171	176	180	183	185	187	190	192	194	196	198	199	203	204	209	210	216	222	
4th	20	27	1.35	165	169	174	176	178	180	183	185	187	188	190	192	195	197	201	202	208	214	
	20	26	1.3	171	176	180	183	185	187	190	192	194	196	198	199	203	204	209	210	216	222	
	21	26	1.238	180	184	189	192	194	197	200	202	204	206	207	209	213	215	219	220	226	233	
	21	25	1.19	187	192	197	200	202	205	208	210	212	214	216	217	222	223	228	229	236	242	
	21	24	1.143	195	200	205	208	211	213	216	219	221	223	225	226	231	232	237	239	245	252	
5th	21	25	1.19	187	192	197	200	202	205	208	210	212	214	216	217	222	223	228	229	236	242	
	21	24	1.143	195	200	205	208	211	213	216	219	221	223	225	226	231	232	237	239	245	252	
	22	24	1.091	204	209	215	218	221	223	227	229	231	233	235	237	242	243	249	250	257	264	
	22	23	1.045	213	219	224	227	230	233	237	239	241	244	246	248	253	254	260	261	268	276	
	23	23	1	223	228	234	238	241	244	247	250	252	254	257	259	264	266	271	273	280	288	
6th	22	24	1.091	204	209	215	218	221	223	227	229	231	233	235	237	242	243	249	250	257	264	
	22	23	1.045	213	219	224	227	230	233	237	239	241	244	246	248	253	254	260	261	268	276	
	23	23	1	223	228	234	238	241	244	247	250	252	254	257	259	264	266	271	273	280	288	
	23	22	0.957	233	239	245	248	252	255	259	261	264	266	268	270	276	278	284	285	293	301	
	24	22	0.917	243	249	256	259	263	266	270	273	275	278	280	282	288	290	296	298	306	315	
			2.667	2.6	2.533	2.5	2.467	2.438	2.4	2.375	2.353	2.333	2.313	2.294	2.25	2.235	2.188	2.176	2.118	2.059	Final ratio	

Machine Settings

Suspension Adjustment

Standard Setting

Always start from standard setting when adjusting the suspension.
If you become confused about adjustment settings, return to the standard setting and start over.

A shock absorber spring length of 289 mm (11.4 in) is the factory specification. As there is some variation between springs from machine, make sure to perform the preloading adjustment again.

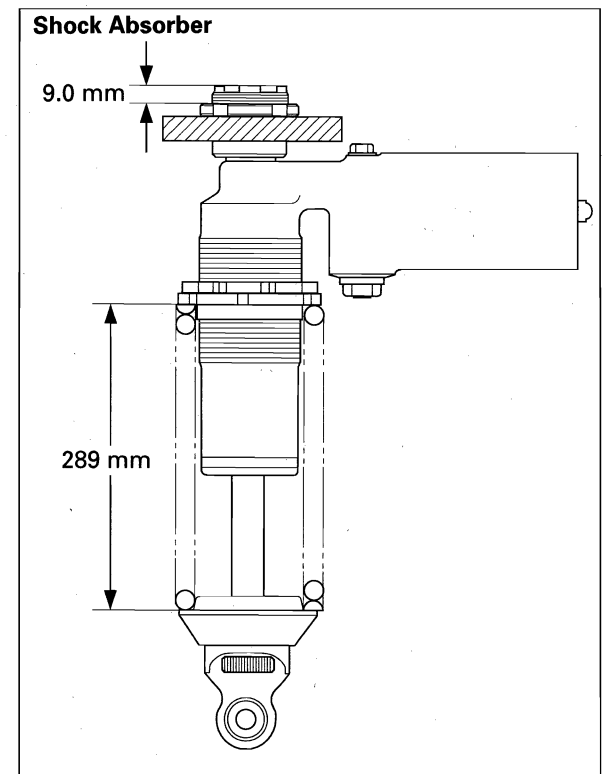
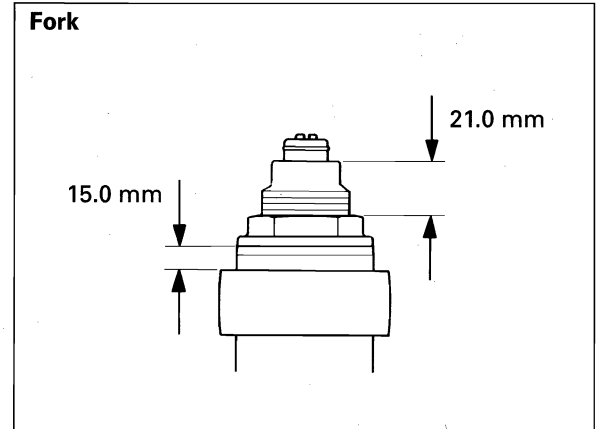

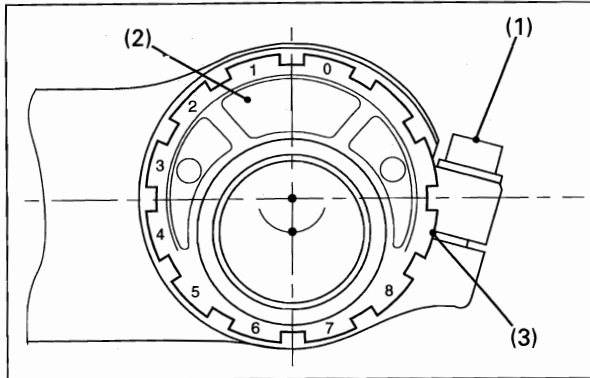

(1) PINCH BOLTS (2) ECCENTRIC BODY
(3) PROJECTION

How To Adjust The Standard Ride Height

Front Suspension

Set the spring pre-load adjuster and fork tube height to the standard position (detail on page 7-6).

Rear Suspension

Set the spring pre-load length and ride height adjuster to the standard position (detail on page 7-6).

NOTICE

- The NSR500V is equipped eccentric axle body that changes the ride height when you move it for adjustment of the drive chain slack. Also the ride height changes if you adjust the spring pre-load length. Always inspect the ride height if you adjust the eccentric body or spring pre-load length.
- Make sure the suspension is not loaded when checking the ride height.

Check and adjust the ride height as follows:

1. Loosen the eccentric body pinch bolts and position the eccentric body as shown. Temporarily note the index number as shown in the illustration.

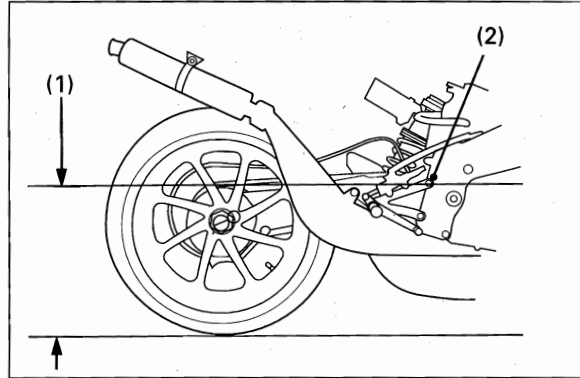

(1) RIDE HEIGHT (2) FOOTPEG HOLDER BOLT

2. Measure the distance between the suitable frame point (example: footpeg holder bolt) and the ground to get reference data for the ride height adjustment.
3. As a pre-load adjustment method matching the rider's weight it is recommended to measure with 1G load applied. The ride height measured in step 2 will change under the weight of the rider. This height change usually amounts to 25 – 30 mm. If it is less than 25 mm, however, pre-load should be reduced, and if it is more than 30 mm, pre-load should be increased.

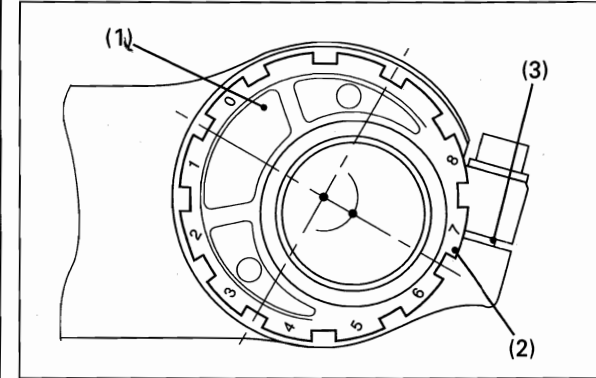

(1) ECCENTRIC BODY (2) PROJECTION
(3) SPLIT

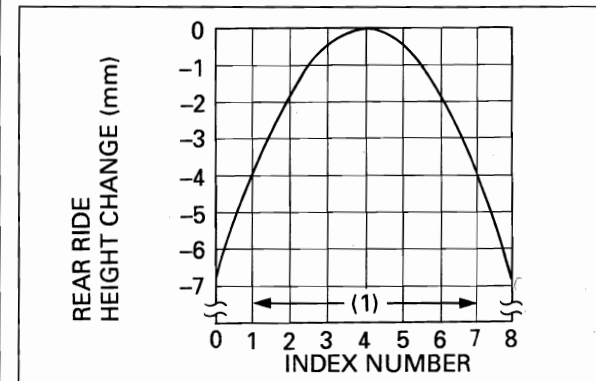

(1) USABLE AREA

4. Adjust the drive chain slack (page 3-4).
5. Inspect the eccentric body position. Check the projection number aligned with the split on the swingarm.
6. Read the ride height change referring to above chart.

Machine Settings

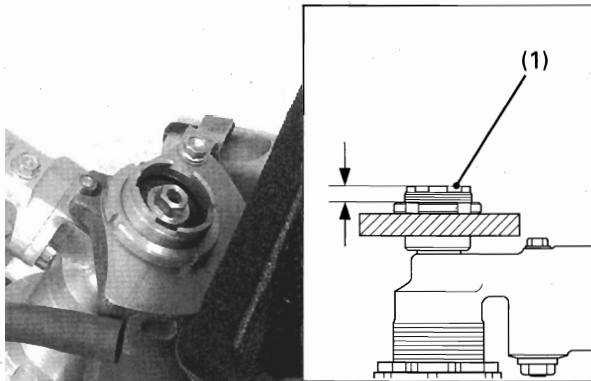

(1) RIDE HEIGHT ADJUSTER

7. Adjust the ride height by turning the ride height adjuster.
Each complete turn is 1.0 mm and ride height changes 3.0 mm (0.12 in).

Example:

Aligned projection number: 6 groove
Ride height change: about - 1.5 mm (0.06 in)
Adjuster turns: $1.5/3.0 = 1/2$ turns out

Recheck the ride height.



(1) O-RING

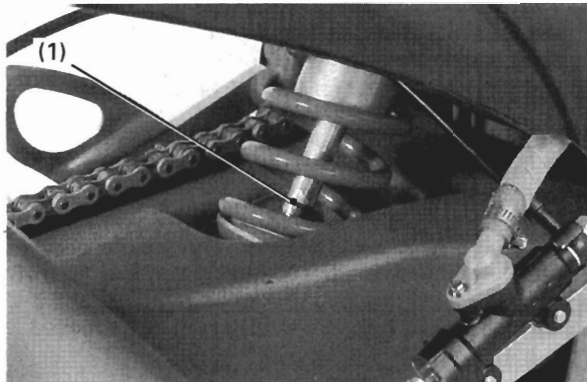

(1) O-RING

How To Obtain The Correct Suspension Stroke

As the first step in setting the suspension, be sure to know the range of the suspension stroke.
For the front and rear suspension use, the installed O-ring.

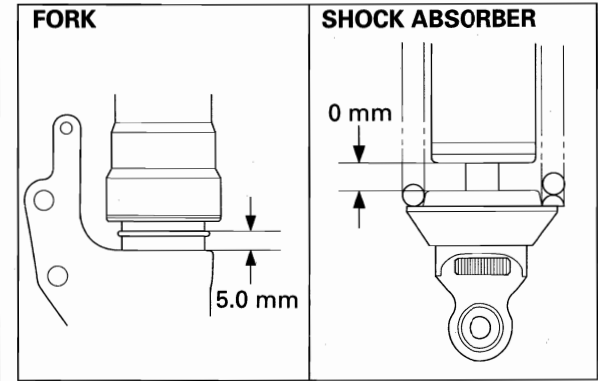

(1) SUSPENSION STOPS POSITION

Suspension stroke is affected by lap times, tire grip, temperature, and many other factors. Test ride your machine as close to your racing speed and pattern as possible.

To get the correct stroke, measure the distance from the suspension stops to the full stroke position with your test ride.
Suspension stops are shown in the illustration above.

Front: 5 mm (0.19 in) from the axle holder
Rear: Damper case fouching the rubber bumper

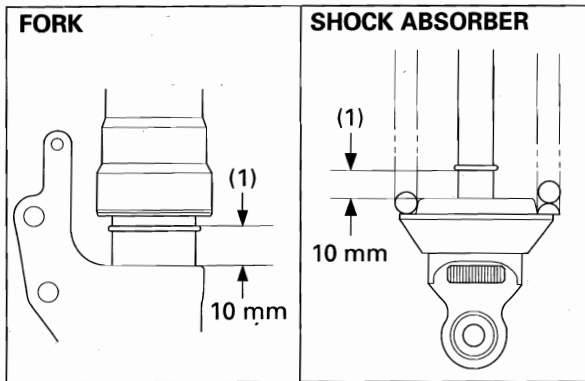

(1) FULLY STROKE POSITION

Set the fully stroke position depending upon test runs so that it is shown in the illustration above.

Front: 10 mm (0.39 in) from the axle holder
Rear: 10 mm (0.39 in) from the rubber bumper

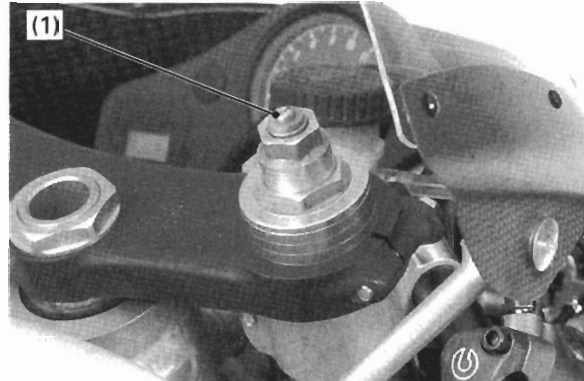

(1) REBOUND ADJUSTER

Front Suspension Adjustment

Rebound Damping Adjustment

The adjuster is located at the center of the fork bolt. Turn the adjuster clockwise to increase damping, counterclockwise to decrease damping. There are 12 - 16 notches between minimum and maximum.

Standard setting: 8 th notch back from maximum

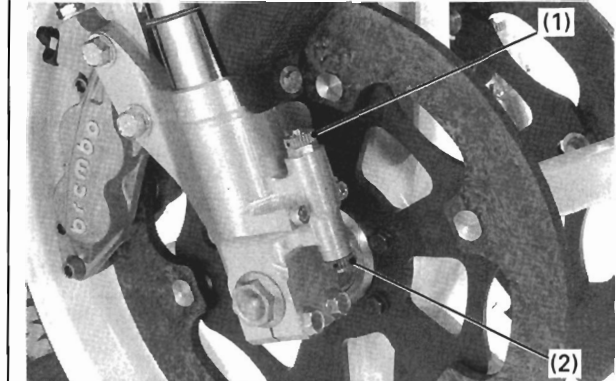

(1) COMPRESSION ADJUSTER (LOW SPEED)
 (2) COMPRESSION ADJUSTER (HIGH SPEED)

Compression Damping Adjustment

The adjuster is located at the bottom of the axle holder.

- High speed (Red)
Turn the adjuster clockwise to increase damping, counterclockwise to decrease damping. There are 12 - 16 notches between minimum and maximum.

Standard setting: 8 th notch back from maximum

- Low speed (Yellow)
Turn the adjuster clockwise to increase damping, counterclockwise to decrease damping. There are 12 - 16 notches between minimum and maximum. The adjuster operate during pitching and nosedive.

Standard setting: minimum position

NOTICE

- Although the damping adjuster can be set between clicks, use the click settings to prevent during motor-cycle operation. If the control moves, the shock absorber might engage at a different setting.
- Do not force the adjuster past its limits.

Machine Settings

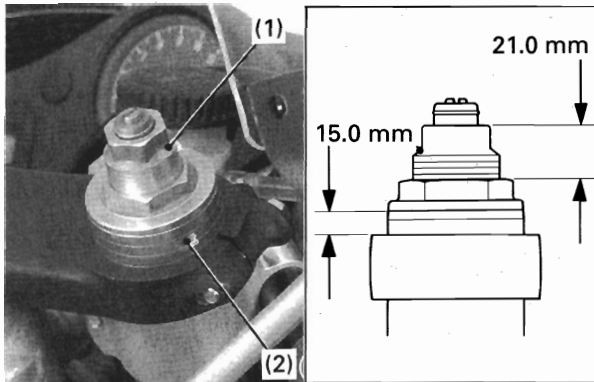

(1) PRELOAD ADJUSTER (2) FORK TUBE HEIGHT

Spring Preload Adjustment

Turn the Preload adjuster clockwise to increase preload and counterclockwise to decrease preload. One complete turn of the preload adjuster corresponds to 1 mm variation in preload.

Adjustment range: 10 – 25 mm (0.39 – 0.98 in)
Standard setting: 21.0 mm (0.83 in)

The height of the machine will change when spring preload is changed. You can maintain the correct ride height with a fork tube adjustment.

NOTICE

Check the clearance between all parts after adjusting.

Fork Tube Height Adjustment

The fork tubes can be adjusted to maintain correct ride height when spring preload is changed.

Adjustment range: 5 – 20 mm (0.19 – 0.79 in)
Standard setting: 15 mm (0.59 in)

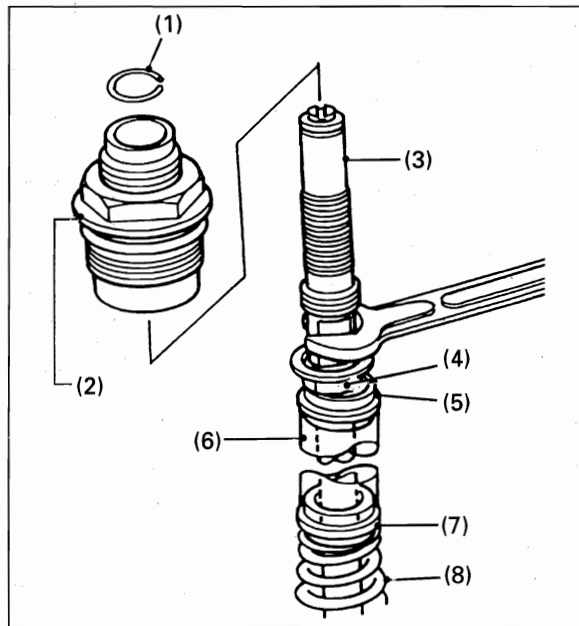

(1) STOPPER RING (2) FORK BOLT (3) ROD
 (4) LOCK NUT (5) SEAT STOPPER
 (6) COLLAR (7) JOINT PLATE (8) SPRING

Fork Spring Replacement

1. Loosen the fork bolt to allow rod to project.
2. Push down spring seat stopper and spring collar and hook then upper lock nut (as shown the illustration).
3. Remove the stopper ring, then loosen the fork bolt completely using a wrench braced on the adjuster case.
Do not loosen the lock nut or you will have to reset your damping adjustment.
4. Remove the spring seat stopper, spring collar and spring joint plate to remove spring.

For reassemble, reverse above mentioned procedures. Spring must be installed with the small coil end face up.

Spring Identification

Spring rate	Identification	Class
0.675 kg/mm	2 coils	Standard
0.625 kg/mm	3 coils	Soft
0.725 kg/mm	1 coils	Hard

NOTICE

After changing, always check remaining stroke of front fork after running, and adjust it to the proper value.

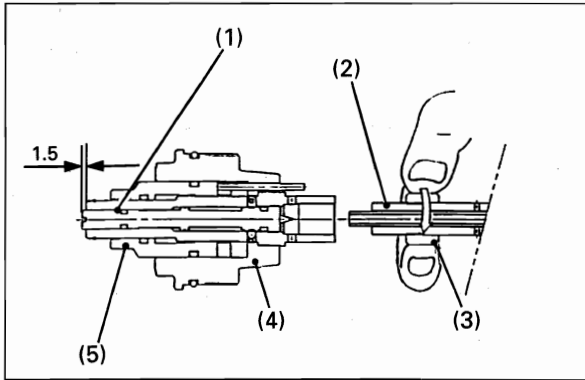

(1) ADJUST PIECE (2) DAMPER ROD
(3) LOCK NUT (4) FORK BOLT
(5) PRELOAD ADJUSTER

Use this procedure to adjust damper rod setting if the lock nut has been loosened.

- A loose lock nut will make it difficult to establish and hold proper damper settings.
1. Turn the damper rod lock nut until it reaches the lower limits of its travel.
 2. Turn the adjuster piece out so that 1.5 mm of the end is exposed. Turn it back and forth slightly until it "clicks" into a detent.

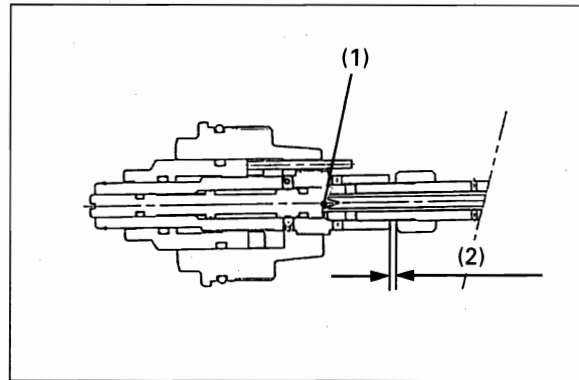

(1) AGAINST (2) CLEARANCE

3. Screw the damper rod into the preload adjuster until seats lightly against the adjuster piece. At this point there should be clearance between the lock nut and preload adjuster.
4. Tighten the lock nut against the preload adjuster, finger tight. Back the adjust piece out one "click" and torque the lock nut.

Torque: 20 N·m (2.0 kg-m, 14 lb-ft)

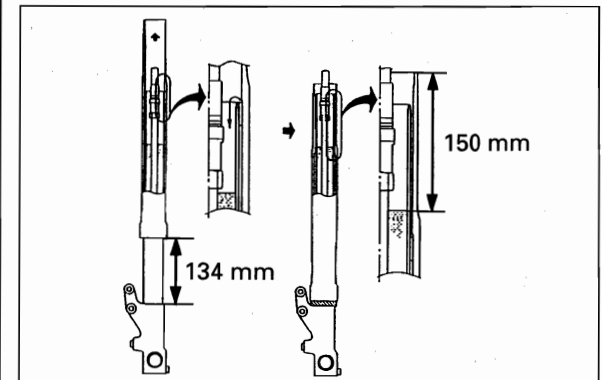

(1) OIL LEVEL

Fluid Level Adjustment

Remove the fork spring from the fork (see fork spring replacement).

Then, fully compress the fork. Be careful not to damage any parts when bottoming the machine.

Press the rod down until it comes into contact with the inner bottom of the fork.

With the rod at this position, the fluid level can be adjusted.

When using this method, the fluid between the outer tube and slide pipe must be drained into slide pipe.

NOTICE

- Temporarily extend the outer tube 134 mm (5.3 in) from the axle holder for the correct fluid level adjustment.
- Down the outer tube onto the axle holder and leave it few minutes.
- Check the oil level at center of fluid surface.

Standard fluid level: 150 mm (435 cc)
Recommended fork fluid: Showa SR6
(51417-NL5-760 Fork Oil Front SR6 - 1 liter)

Machine Settings

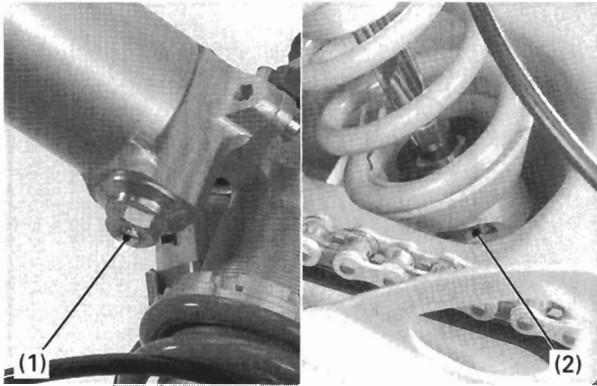

(1) COMPRESSION ADJUSTER
(2) REBOUND ADJUSTER

Rear Suspension adjustment

Compression Damping Adjustment

The compression damping adjuster is on the under side of the reservoir.

Turn the adjuster toward the H mark to increase damping.

Turn the adjuster toward the S mark to decrease damping.

The adjuster has 22 – 26 notches with 10 notches for one full turn.

Standard position: 10 th notch back from maximum

Rebound Damping Adjustment

The rebound damping adjuster is at the base of the shock absorber.

Turn the dial toward the H mark to increase damping.

Turn the dial toward the S mark to decrease damping.

The dial has 12 – 16 notches with a detent every 60 degree.

Standard position: 12 th notch back from maximum

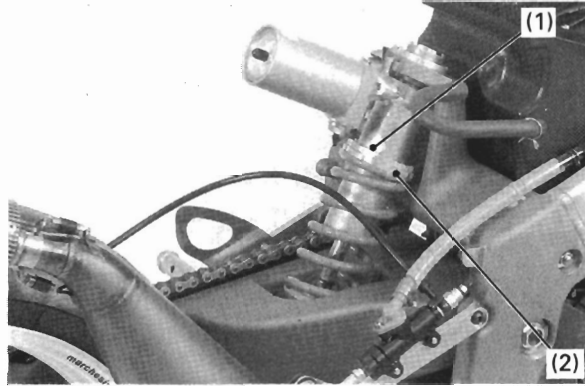

(1) LOCK NUT (2) ADJUST NUT

Spring Preload Adjustment

Loosen the lock nut and turn the spring preload adjuster. One full turn changes the length of the spring by 1.5 mm and ride height changes 4.5 mm.

To prevent damage to the shock mounts and to assure the lock nut is properly tightened, use two wrenches to tighten the lock nut.

Standard installed length: 289 mm (11.4 in)

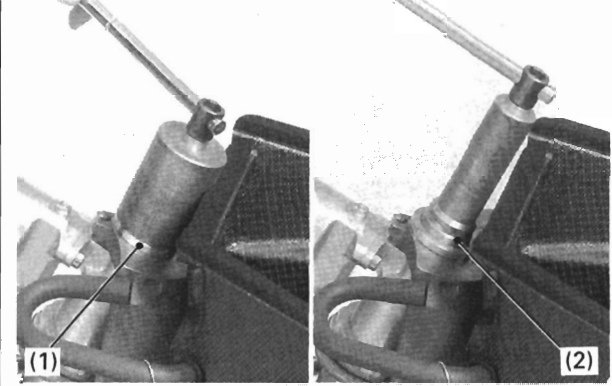

(1) LOCK NUT (2) RIDE HEIGHT ADJUSTER

Ride Height Adjustment

Make sure the suspension is not loaded when checking the ride height.

To adjust ride height, loosen the lock nut at the rear shock absorber upper joint and turn the ride height adjuster at the upper joint to the desired position. Each complete turn is 1.0 mm and change the ride height 3 mm.

TOOL:

JIG A RR CUSSION

89501-NC8-000

JIG B RR CUSSION

89502-NC8-000

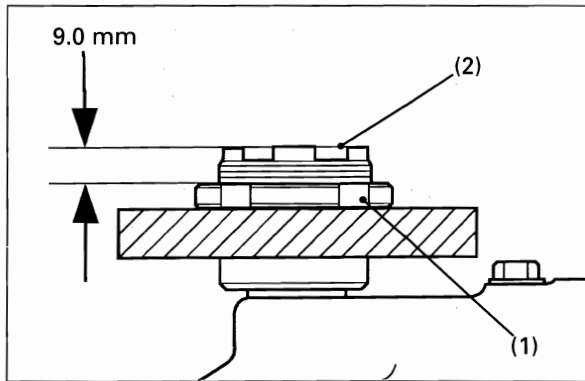

(1) LOCK NUT (2) RIDE HEIGHT ADJUSTER

Standard length: 9.0 mm (0.35 in)

Adjustment range: ± 5 mm (± 0.19 in) from standard length

After adjustment, tighten the lock to 35 N·m (3.5 kg·m, 25 ft·lb).

Spring Identification

Spring rate	Identification	Class
6.0 kg/mm	Yellow	Standard
5.6 kg/mm	White	Soft
6.4 kg/mm	Blue	Hard

Spring Replacement

Remove the rear shock absorber, then remove the spring.

Install the rear shock absorber spring.
Adjust the ride height (page 7-8).

Memo

'97-'98-NSR500V PARTS LIST

CONTENTS

INSTRUCTIONS FOR USE OF PARTS LIST 2-2

ENGINE GROUP

E-1	Cylinder. Cylinder head	2-3
E-2	R. Crankcase cover	2-4
E-3	Exhaust valve pulley Rear adjuster rod	2-5
E-4	A. C. generator	2-6
E-5	Water pump	2-7
E-6	Crankcase	2-8-9
E-7	Crankshaft	2-10
E-8	Transmission	2-11-12
E-9	Gearshift fork Gearshift drum	2-13
E-10	Carburetor	2-14-15

FRAME GROUP

F-1	Servo motor • Meter Meter panel	2-16
F-2	Cable • Switch Handlebar	2-17
F-3	Front brake caliper Front brake mastercylinder	2-18
F-4	Steering stem Steering damper Front fender	2-19
F-5	Front wheel	2-20
F-6	Rear brake caliper Rear brake master cylinder	2-21
F-7	Rear wheel	2-22
F-8	Fuel tank	2-23
F-9	Carburetor box	2-24
F-10	Expansion chamber	2-25
F-11	Gearshift pedal Footpeg	2-26
F-12	Swingarm	2-27
F-13	Shock absorber (Front fork) (Rear cushion)	2-28
F-14	Ignition coil Wire harness	2-29
F-15	Frame body	2-30
F-16	Radiator	2-31
F-17	Cowl	2-32
INDEX		2-33-34-35-36

INSTRUCTIONS FOR USE OF PARTS LIST

This parts list is to be used when ordering replacement parts; it contains all parts for model '97-'98- NSR500V

I. How to order parts

● Information required

Replacement parts orders/must contain both the part number and the stamped number(s) as described below. This is because any changes and modifications of parts are registered at HONDA with the pertinent parts and stamped numbers.

- If quantities are shown in (), the parts are optional.
- If "N" is indicated in the quantity column, the parts quantity is to be determined as required.

II. How to read this parts list

● Make-up of the part number

(Example) General parts

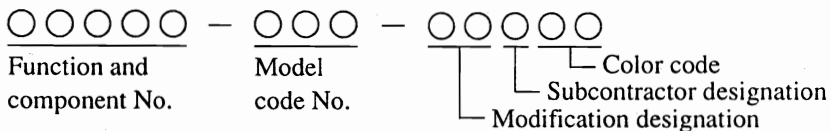

(Example) Bolts, nuts and other standard parts

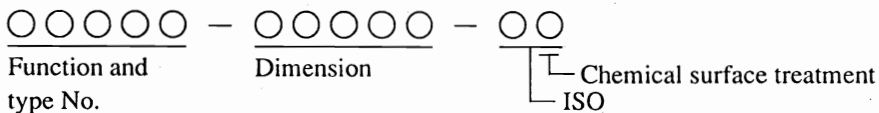

● Abbreviations

The following abbreviations are used in this parts list.

A.C. Alternating current	M. Middle
ASSY. Assembly	mm Millimeter
C. Center	R. Right
COMP. Complete	STD. Standard
G. Gram	T(22T). Tooth (22 Teeth)
L. Left	T.W. Thermo Water
L (100L). Link (100 Links)	

● Serial number

Frame No. NSR500VF-71001~('97), NSR500VF-81001~('98)
 Engine No. NSR500VE-71001~('97), NSR500VE-81001~('98)

IMPORTANT INFORMATION

- The parts which have a dot "•" on the left side of the "Ref. No." are exclusive for HRC products. To purchase these parts, consult your Honda dealer.
- The parts which have no dot are Honda products and can be purchased from your nearest Honda motorcycle dealer, or from HRC-JAPAN/EUROPE if you can't obtain the parts locally.

MEMO

REVISION OF '98NSR500V PARTS LIST

97.12.26
HRC Service

- 1, '98Model crankcase No. B1 and B18 must be installed
91012-NX6-003. BEARING, ball 62/28

'98Model crankcase from No. B2 to B17 and B19 must be installed
91012-NX6-303. BEARING, ball 62/28

The case number is stamped as the picture in below.

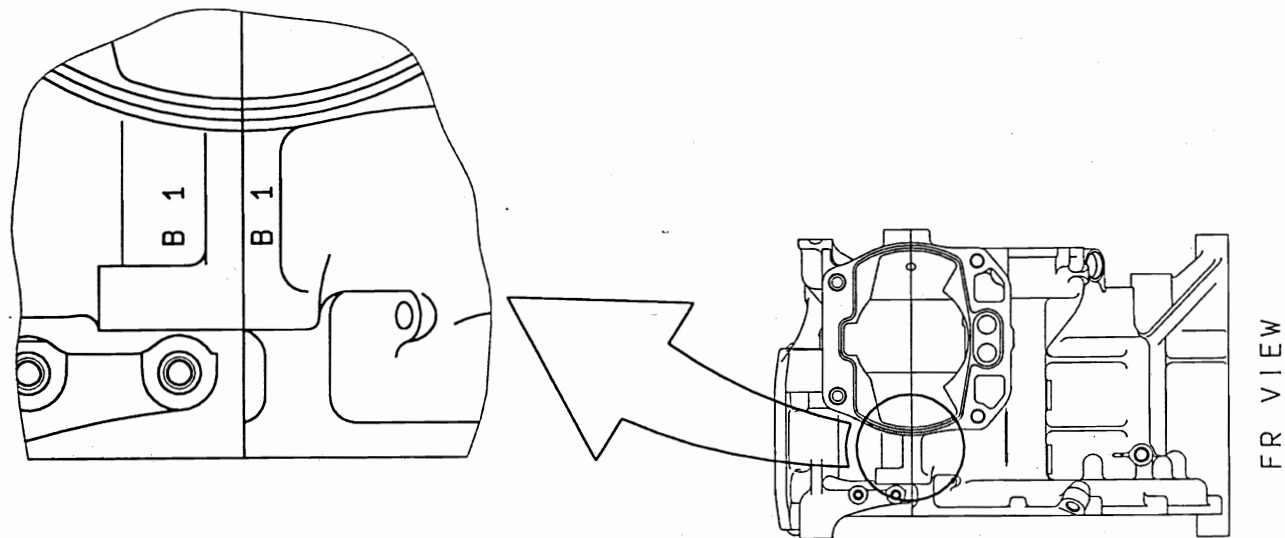

2, REVISION OF PARTS NUMBER

BLOCK No.	INDEX PAGE	OLD PART No. OLD DESCRIPTION		NEW PART No. NEW DESCRIPTION
E-7	2-33	13121-NX6-700 RING,piston	→	13121-NX6-701 RING,piston
E-8	2-35	90404-KV3-830 WASHER,10mm	→	90404-NX6-700 WASHER,10 × 36 × 3.8
E-7	2-35	91001-NX6-700 BEARING,A.63/28spl	→	91001-NX6-701 BEARING,A.63/28spl
F-3	2-36	95003-11015-60 V-TUBE,5 × 9 × 150	→	95003-11012-60 V-TUBE,5 × 9 × 120
F-7	2-34	42615-NX6-000 FLANGE,driven	→	42615-NX6-700 FLANGE,driven

Block No.

E-1

Cylinder, Cylinder head

'97 NSR500V

'98 NSR500V

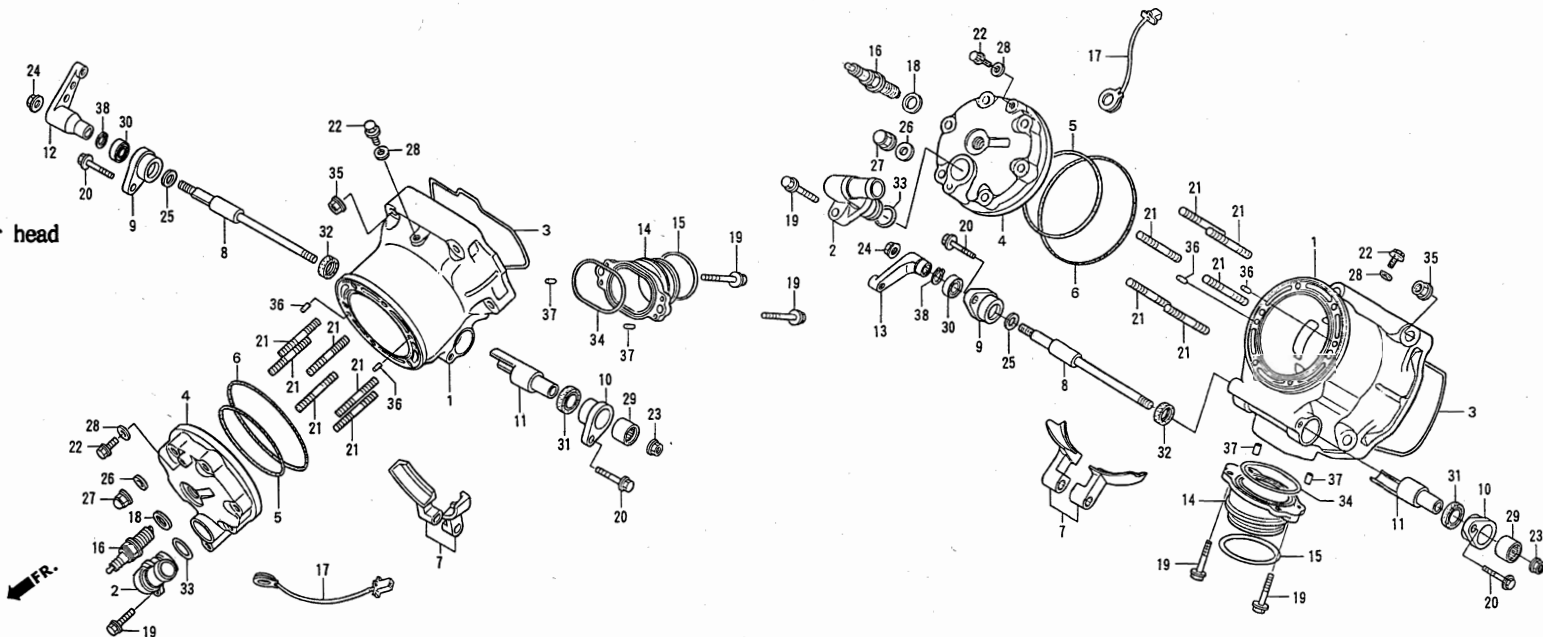

Ref. No.	Part No.	Description	Reqd. No.	Remarks	Ref. No.	Part No.	Description	Reqd. No.	Remarks	
			'97 '98					'97 '98		
• 1	12101-NX6-000	CYLINDER,	2	—	• 21	90006-NX6-000	BOLT, stud(2) 8×32	12	12	
•	12101-NX6-700	CYLINDER,	—	2	• 22	90037-NX5-000	BOLT, water check 6×10	4	4	
2	12103-KZ3-700	JOINT, water hose	2	2	• 23	90204-NX6-000	NUT, flange 7mm LH	2	2	
• 3	12191-NX6-000	GASKET, cylinder	2	2	• 24	90205-NX6-000	NUT, flange 7mm	2	2	
• 4	12211-NX6-000	HEAD, cylinder	2	—	For unleaded	• 25	90404-NX6-000	SHIM, 8mm T0.9	N	N
•	12211-NX6-600	HEAD, cylinder	(2)	—	For leaded	•	90405-NX6-000	SHIM, 8mm T1.0	N	N
•	12211-NX6-700	HEAD, cylinder	—	2	For unleaded	•	90406-NX6-000	SHIM, 8mm T1.1	N	N
• 5	12212-NX6-003	O-RING, 74×2	2	2	•	90407-NX6-000	SHIM, 8mm T1.2	N	N	
•	12213-NX6-003	O-RING, 103×1.9	2	2	•	90408-NX6-000	SHIM, 8mm T1.3	N	N	
• 6	14210-NX6-305	VALVE, set exhaust	2	2	•	90409-NX6-000	SHIM, 8mm T1.4	N	N	
• 7	14311-NX6-000	SHAFT, exhaust valve	2	2	26	90441-422-000	WASHER, sealing 8mm	12	12	
• 8	14312-NX6-000	HOLDER, A. valve shaft	2	2	27	90443-107-000	NUT, cap 8mm	12	12	
• 9	14312-NX6-000	HOLDER, A. valve shaft	2	2	28	90543-273-000	PACKING, front fork drain	4	4	
• 10	14313-NX6-000	HOLDER, B. valve shaft	2	2	29	91024-GJ5-003	BEARING, needle 12×16×10	2	2	
• 11	14315-NX6-000	COLLAR, valve shaft	2	2	• 30	91034-NX6-003	BEARING, ball 8×19×6	2	2	
• 12	14411-NX6-000	ARM, front cylinder	1	1	31	91205-KF0-003	OIL SEAL, 12×20×5	2	2	
• 13	14421-NX6-000	ARM, rear cylinder	1	1	32	91205-PH8-005	OIL SEAL, 12×18×4	2	2	
• 14	18351-NX6-000	JOINT, exhaust	2	—	33	91301-147-023	O-RING, 18.3×2.3	2	2	
•	18351-NX6-700	JOINT, exhaust	—	2	• 34	91302-NX6-003	O-RING, 47×1.8	2	2	
• 15	18352-NX6-000	SEAL, chamber	2	2	35	94050-10000	NUT, flange 10mm	8	8	
• 16	31940-NX6-000	SPARK PLUG, R6120M-105	2	2	36	94301-06100	DOWEL PIN, 6×10	4	4	
• 17	38510-NX6-600	SENSOR ASSY, PI	(2)	2	37	94303-04065	DOWEL PIN, 4×6.5	4	4	
• 18	38511-NX6-000	WASHER, spark plug	2	(2)	38	94520-19000	CIRCLIP, internal 19	2	2	
• 19	90004-GHB-650	BOLT, flange NSHF 6×20	6	6						
20	90004-GHB-660	BOLT, flange NSHF 6×22	4	4						

Block No.

E-2

R. Crankcase cover
Clutch

'97 NSR500V
'98 NSR500V

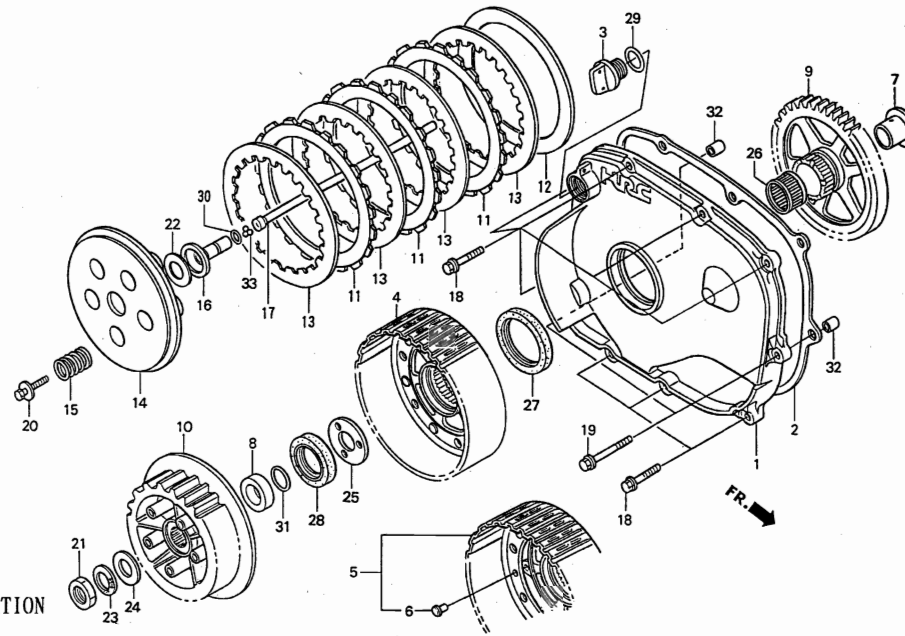

NOTE: Ref No. 8, 31.
CAN BE APPLY FOR TYPE '97 IN CASE OF COMBINATION
WITH 22108-NX6-700 AND 91361-NX6-700.

Ref. No.	Part No.	Description	Reqd. No.		Remarks	Ref. No.	Part No.	Description	Reqd. No.		Remarks
			'97	'98					'97	'98	
• 1	11331-NX6-000	COVER, R. crankcase	1	1		• 21	90208-NX6-000	NUT, lock 22mm	1	1	
• 2	11395-NX6-000	GASKET, R. cover	1	1		• 22	90411-NX6-000	SHIM, clutch adjusterT0.8	(1)	(1)	
• 3	15611-NF4-900	CAP, oil filler	1	1		•	90412-NX6-000	SHIM, clutch adjusterT1.2	(1)	(1)	
• 4	22100-NX6-000	OUTER COMP. clutch	1	1		•	90413-NX6-000	SHIM, clutch adjusterT1.6	1	1	
• 5	22100-NX6-305	OUTER SET, clutch	1	1		•	90414-NX6-000	SHIM, clutch adjusterT2.0	(1)	(1)	
• 6	22103-HA0-300	RIVET, 7mm	6	6		•	90415-NX6-000	SHIM, clutch adjusterT2.4	(1)	(1)	
• 7	22106-NX6-000	COLLAR, primary driven gear	1	1		23	90432-MB0-010	WASHER, spring 22mm	1	1	
• 8	22108-NX6-000	COLLAR, 25×34×7.5	1	—		24	90451-KG4-000	WASHER, thrust 22×39×2	1	1	
•	22108-NX6-700	COLLAR, 27.2×34×7.5	(1)	1	NOTE	• 25	90497-NX6-000	WASHER, 25mm	1	1	
• 9	22111-NX6-000	GEAR, primary driven P-1(52T)	(1)	(1)		26	91021-415-005	BEARING, needle 32mm	1	1	
•	22112-NX6-000	GEAR, primary driven P-2(53T)	1	1		• 27	91222-NX6-003	OIL SEAL, 54×66×7	1	1	
•	22113-NX6-000	GEAR, primary driven P-3(54T)	(1)	(1)		28	91253-KM1-003	OIL SEAL, 34×52×5	1	1	
• 10	22120-NX6-000	CENTER, clutch	1	1		29	91304-MJ0-003	O-RING	1	1	
• 11	22201-NX6-000	DISK, clutch friction	7	7		• 30	91312-NC8-000	O-RING, 10.6×1.3	1	1	
• 12	22210-NX6-000	SPACER, clutch	1	1		31	91361-MT3-003	O-RING, 24.5×1.9	1	—	
• 13	22321-NX6-000	PLATE, clutch	8	8		•	91361-NX6-700	O-RING, 24.5×1.4	(1)	1	NOTE
• 14	22351-NX6-000	PLATE, clutch pressure	1	1		32	94301-08100	DOWEL PIN, 8×10	2	2	
• 15	22401-NX6-000	SPRING, clutch	5	5		33	96211-07000	BALL STEEL, 7	3	3	
• 16	22841-NX6-000	PIECE, clutch lifter	1	1							
• 17	22850-NX6-000	ROD COMP. clutch lifter	1	1							
• 18	90004-GHB-650	BOLT, flange NSHF 6×20	8	8							
19	90004-GHB-680	BOLT, flange NSHF 6×28	2	2							
20	90022-MM5-000	BOLT WASHER, 6×25	5	5							

Block No.

E-3

Exhaust valve pulley
Rear adjuster rod

'97 NSR500V
'98 NSR500V

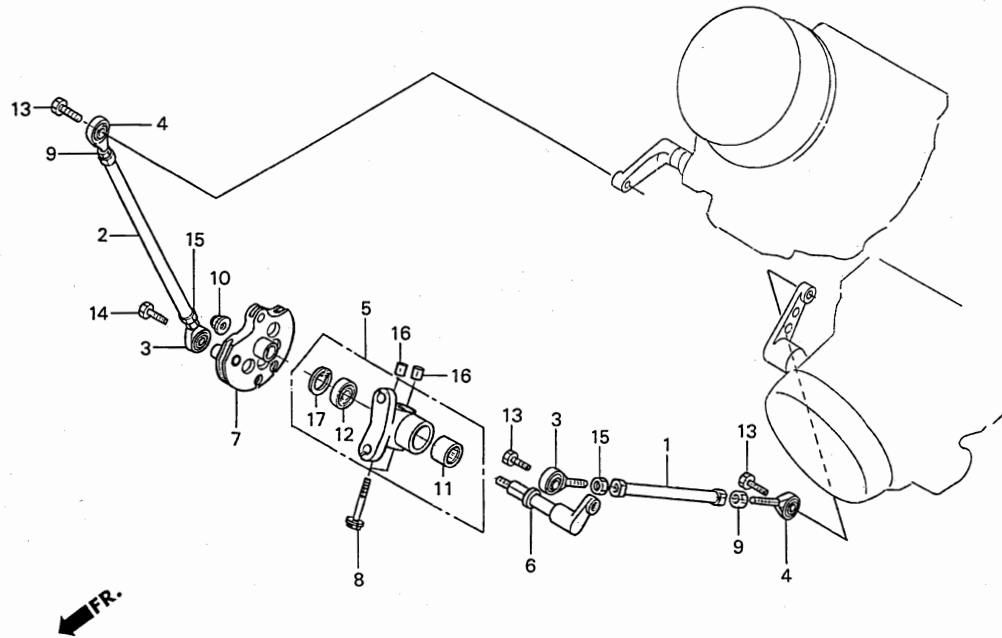

Ref. No.	Part No.	Description	Reqd. No.		Remarks	Ref. No.	Part No.	Description	Reqd. No.		Remarks
			'97	'98					'97	'98	
• 1	14248-NX6-000	ADJUSTER ROD, front	1	1							
• 2	14249-NX6-000	ADJUSTER ROD, rear	1	1							
• 3	14337-NX5-003	ROD-END, 5mm	2	2							
• 4	14338-NX5-003	ROD-END, 5mm LH	2	2							
• 5	18100-NX6-000	HOLDER, ASSY. pulley	1	1							
• 6	18152-NX6-000	SHAFT, driven pulley	1	1							
• 7	18155-NX6-000	PULLEY, driven	1	1							
8	90004-GHB-720	BOLT, flange NSHF 6×45	2	2							
• 9	90201-NF5-000	NUT, LH. 5mm	2	2							
10	90301-473-003	NUT, U. 6mm	1	1							
11	91024-GJ5-003	BEARING, needle 12×16×10	1	1							
• 12	91034-NX6-003	BEARING, ball 8×19×6	1	1							
13	92301-05014-0A	BOLT(recessed), 5×14	3	3							
14	92301-05016-0A	BOLT(recessed), 5×16	1	1							
15	94001-05000-0S	NUT, hex 5mm	2	2							
16	94301-08100	DOWEL PIN, 8×10	2	2							
17	94520-19000	CIRCLIP, internal 19	1	1							

Block No.

E-4

A. C. generator

'97 NSR500V

'98 NSR500V

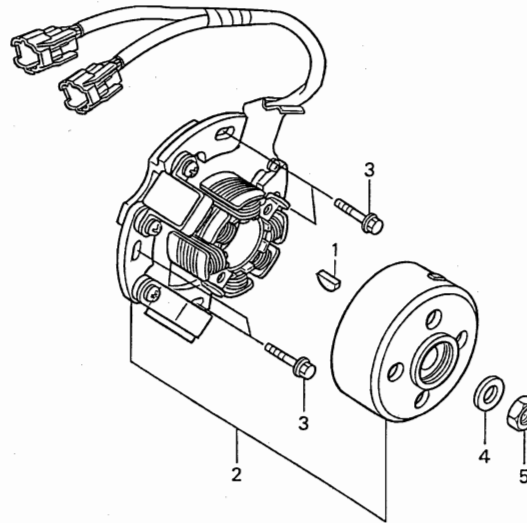

Ref. No.	Part No.	Description	Reqd. No.		Remarks	Ref. No.	Part No.	Description	Reqd. No.		Remarks
			'97	'98					'97	'98	
1	13331-360-000	KEY, special woodruff 25×14	1	1							
• 2	31100-NX6-003	A. C. GENERATOR ASSY.	1	—							
•	31100-NX6-700	A. C. GENERATOR ASSY.	(1)	1							
• 3	90004-GHB-650	BOLT, flange NSHF 6×20	4	4							
• 4	90441-NX6-700	WASHER, plain 12mm	1	1							
5	94001-12200-0S	NUT, hex 12mm	1	1							

Block No.

E-5

Water pump

'97 NSR500V

'98 NSR500V

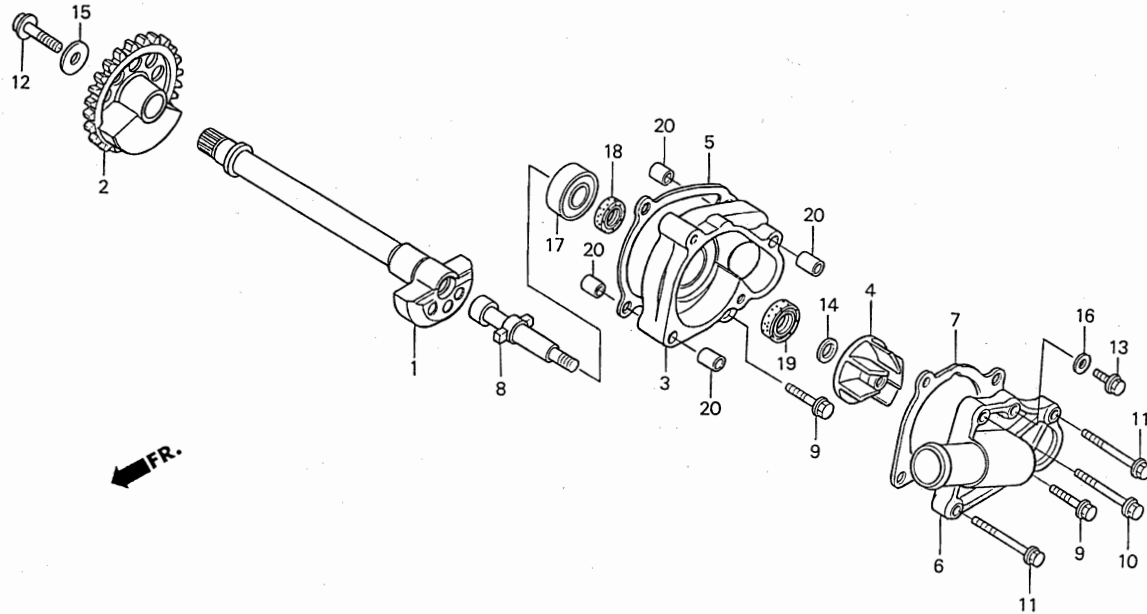

Ref. No.	Part No.	Description	Reqd. No.		Remarks	Ref. No.	Part No.	Description	Reqd. No.		Remarks
			'97	'98					'97	'98	
• 1	13420-NX6-000	SHAFT COMP. balancer	1	1							
• 2	13426-NX6-000	GEAR, balancer driven	1	1							
• 3	19210-NX6-000	BODY, water pump	1	1							
• 4	19215-NX6-000	IMPELLER, water pump	1	1							
• 5	19219-NX6-000	GASKET, water pump body	1	1							
• 6	19220-NX6-000	COVER, water pump	1	1							
• 7	19229-NX6-000	GASKET, water pump cover	1	1							
• 8	19233-NX6-000	SHAFT, water pump	1	1							
9	90004-GHB-670	BOLT, flange NSHF 6×25	2	2							
10	90004-GHB-720	BOLT, flange NSHF 6×45	1	1							
11	90004-GHB-730	BOLT, flange NSHF 6×50	2	2							
• 12	90004-NX6-000	BOLT, flange 10×30	1	1							
• 13	90037-NX5-000	BOLT, water check 6×10	1	1							
14	90447-KE1-000	WASHER, sealing 7mm	1	1							
15	90501-MB7-610	WASHER, 10.3×25	1	1							
16	90543-273-000	PACKING, front fork drain	1	1							
17	91001-KA4-003	BEARING, ball 12×28×7	1	1							
18	91201-965-000	OIL-SEAL, 12×22×5	1	1							
19	91211-KA3-761	SEAL, water pump	1	1							
20	94301-08100	DOWEL PIN, 8×10	4	4							

Block No.

E-6

Crankcase

'97 NSR500V
'98 NSR500V

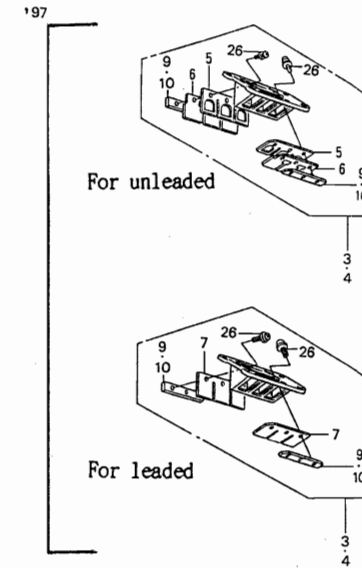
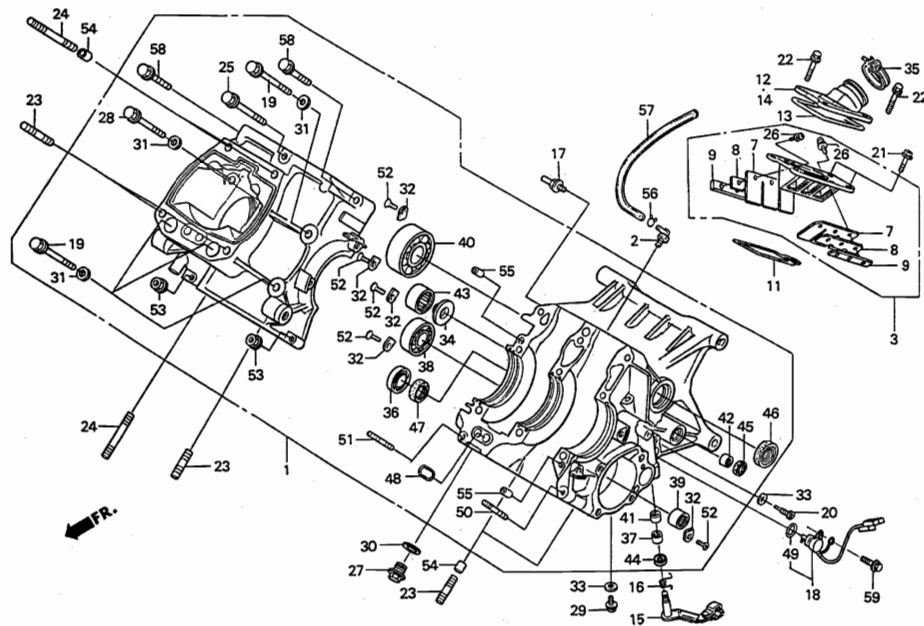

NOTE: Ref No. 3, 7, 8, 9.
CAN BE APPLY FOR TYPE '97 IN CASE OF ASSEMBLY CONDITION

Ref. No.	Part No.	Description	Reqd. No.		Remarks	Ref. No.	Part No.	Description	Reqd. No.		Remarks
			'97	'98					'97	'98	
- 1	11000-NX6-305	CRANKCASE SET,	1	—		• 16	22815-NX6-000	SPRING, clutch lever	1	1	
-	11000-NX6-306	CRANKCASE SET,	(1)	1	See attached sheet	• 17	24615-NX6-000	PIN, shift stopper	1	1	
2	11106-GM2-300	JOINT, breather	1	—		• 18	35750-NX6-700	SWITCH ASSY. change	—	1	
• 3	14100-NX6-000	REED VALVE ASSY. front	1	—	For unleaded	• 19	90001-NX6-000	BOLT, flange 9×105	4	4	
•	14100-NX6-600	REED VALVE ASSY. front	(1)	—	For leaded	• 20	90002-NX6-000	BOLT, special 6mm	1	1	
•	14100-NX6-701	REED VALVE ASSY.	(2)	2	For unleaded	21	90004-GHB-630	BOLT, flange NSHF 6×16	4	4	
• 4	14110-NX6-000	REED VALVE ASSY. rear	1	—	For unleaded	• 22	90004-GHB-650	BOLT, flange NSHF 6×20	8	8	
•	14110-NX6-600	REED VALVE ASSY. rear	(1)	—	For leaded	• 23	90008-NX6-000	BOLT, stud (2) 10×45	5	5	
• 5	14111-NX6-000	REED VALVE, A	4	—	For unleaded	• 24	90009-NX6-000	BOLT, stud (2) 10×55	3	3	
• 6	14112-NX6-000	REED VALVE, B	4	—	For unleaded	25	90014-KV3-680	BOLT, flange 8×105	1	1	
• 7	14112-NX6-600	REED VALVE, only 0.42	—	4	For unleaded	• 26	90021-NX6-000	SCREW-WASHER, 3×7	12	12	
			(4)	—	For leaded	• 27	90080-NX6-000	BOLT COMP. drain 10×13	1	1	
			(4)	—	NOTE	• 28	90082-NX5-000	BOLT, flange 9×87	2	2	
• 8	14113-NX6-701	SUPPORTER, reed valve	(4)	4	NOTE	• 29	90134-NX5-000	BOLT, drain 6×10	1	1	
• 9	14121-NX6-000	STOPPER, front reed valve	2	4	PRINTED "FR"	30	90443-MB0-000	WASHER, sealing 10mm	1	1	
			(4)	—	NOTE	31	90445-MM4-000	WASHER, 9mm	6	6	
• 10	14122-NX6-000	STOPPER, rear reed valve	2	—	PRINTED "RR"	• 32	90471-NX6-000	STOPPER, bearing 10	5	5	
• 11	14131-NX6-000	GASKET, reed valve	2	2		33	90543-273-000	PACKING, front fork drain	2	2	
• 12	16210-NX6-000	INSULATOR, front carburetor	1	1		34	90558-MB0-000	PLATE, orifice	1	1	
• 13	16219-NX6-000	GASKET, carburetor insulator	2	2		35	90652-GHB-690	BAND, 52 air/c connecting tube	2	2	
• 14	16220-NX6-000	INSULATOR, rear carburetor	1	1		36	91001-GBT-003	BEARING, ball 6802	1	1	
• 15	22810-NX6-000	LEVER COMP. clutch	1	1		37	91002-HA2-008	NEEDLE, shell 10×17×10	1	1	

Block No.

E-6

Crankcase

'97 NSR500V

'98 NSR500V

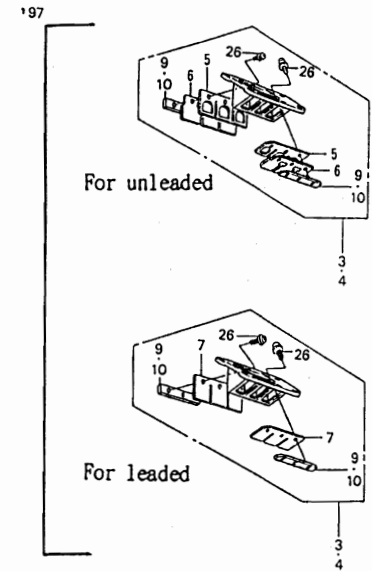
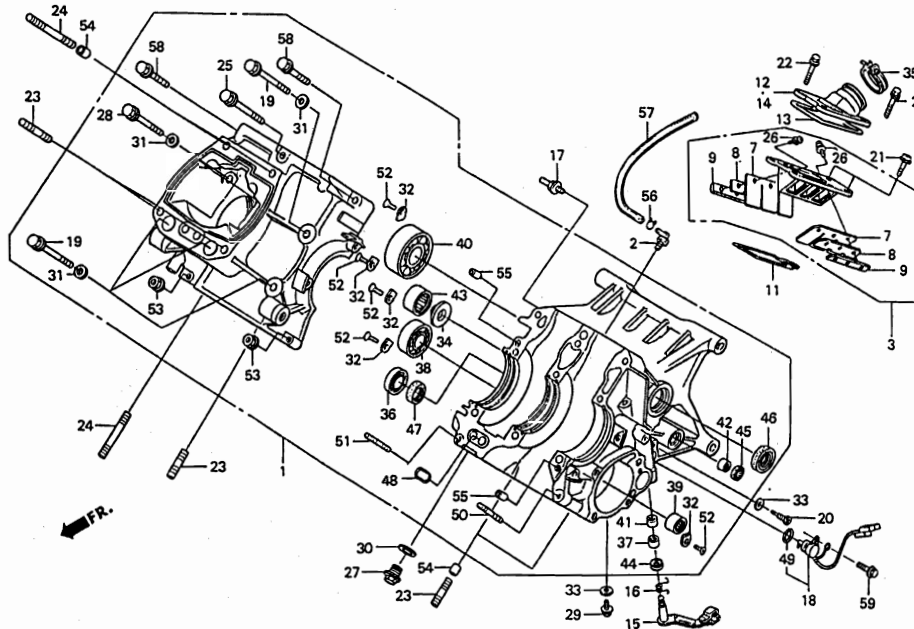

NOTE: Ref No. 3, 7, 8, 9.

CAN BE APPLY FOR TYPE '97 IN CASE OF ASSEMBLY CONDITION

Ref. No.	Part No.	Description	Reqd. No.		Remarks	Ref. No.	Part No.	Description	Reqd. No.		Remarks
			'97	'98					'97	'98	
• 38	91004-NX6-003	BEARING, ball radial 6004 special	1	—		58	95701-08055-00	BOLT, flange 8×55	2	2	
•	91004-NX6-701	BEARING, ball radial 6004 special	(1)	1		59	96001-06012-00	BOLT, flange SH 6×12	—	1	
• 39	91008-NX6-003	BEARING, needle 24×36×14	1	1							
• 40	91012-NX6-003	BEARING, ball 62/28	1	(1)	See attached sheet						
•	91012-NX6-303	BEARING, ball 62/28	—	1							
41	91021-148-006	BEARING, needle 1010	1	1							
• 42	91023-NX6-003	BEARING, needle 15×21×10	1	1							
• 43	91024-NX6-003	BEARING, needle 20×34×18	1	1							
44	91201-VA4-801	OIL-SEAL, 10×20×5	1	1							
45	91204-GK8-003	OIL-SEAL, 15×24×5	1	1							
• 46	91204-NX6-000	OIL-SEAL, 36×46×6	1	1							
47	91210-723-751	OIL-SEAL, 12×21×5	1	1							
• 48	91303-NX6-000	O-RING, 26×1.6	1	1							
49	91305-KK4-003	O-RING, 16.5×2.5	—	1							
50	92900-06028-0B	BOLT, stud (2) 6×28	1	1							
51	92900-06035-0B	BOLT, stud (2) 6×35	1	1							
52	93600-06012-0A	SCREW, flat 6×12	5	5							
53	94050-06000	NUT, flange 6mm	2	2							
54	94301-12160	DOWEL PIN, 12×16	4	4							
55	94303-08140	DOWEL PIN, 8×14	2	2							
56	95002-02070	CLIP, B7 tube	1	1							
• 57	95003-10030-31	V-TUBE, 5×8×300	1	1	Available length IN only						

Block No.

E-7

Crankshaft
Piston

'97 NSR500V
'98 NSR500V

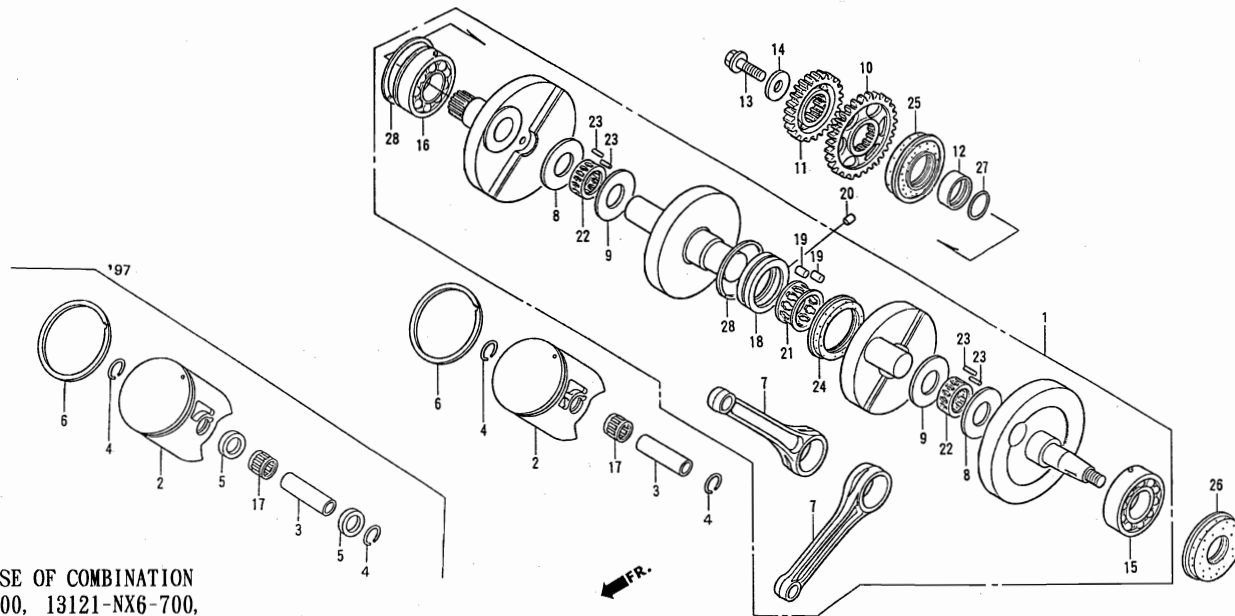

NOTE:Ref No. 2, 3, 6, 17.
CAN BE APPLY FOR TYPE '97 IN CASE OF COMBINATION
WITH 13100-NX6-700 , 13111-NX6-700, 13121-NX6-700,
AND 91005-NX6-701.

Ref. No.	Part No.	Description	Reqd. No.		Remarks	Ref. No.	Part No.	Description	Reqd. No.		Remarks
			'97	'98					'97	'98	
• 1	13000-NX6-000	CRANKSHAFT COMP.	1	—		• 19	91101-NX6-003	ROLLER, crank bearing A	11	11	
• 2	13100-NX6-303	PISTON COMP.	(1)	1		• 20	91102-NX6-003	ROLLER, crank bearing B	(11)	(11)	
• 3	13111-NX6-000	PIN, piston	(2)	2	NOTE	• 21	91103-NX6-003	ROLLER, crank bearing C	(11)	(11)	
• 4	13112-NX6-010	CLIP, piston pin 17mm	(2)	2	NOTE	• 22	91104-NX6-003	ROLLER, crank bearing D	(11)	(11)	
• 5	13115-NX6-303	SPACER, small-end	(2)	2	NOTE	• 23	91105-NX6-003	ROLLER, crank bearing E	(11)	(11)	
• 6	13121-NX6-003	RING, piston	4	4		• 24	91102-230-000	ROLLER, 5×10	1	1	
• 7	13201-NX6-300	ROD, connecting	4	4		• 25	91106-NX6-003	RETAINER, crank bearing	1	1	
• 8	13202-NX6-300	PLATE, A. connecting rod side	2	2		• 26	91110-NX6-003	RETAINER, con rod L end	2	—	
• 9	13203-NX6-300	PLATE, B. connecting rod side	(2)	2	NOTE	• 27	91110-NX6-701	RETAINER, con rod L end	(2)	2	For L14.3
• 10	13415-NX6-000	GEAR, balancer drive	2	2		• 28	91112-NX6-003	ROLLER, 4.0×14.8 A	(32)	32	L14.3
• 11	13615-NX6-000	GEAR, primary drive (27T)	2	2		• 29	91112-NX6-701	ROLLER, 4.0×14.3 A	(32)	32	L14.3
• 12	13617-NX6-000	COLLAR, crank shaft	2	2		• 30	91113-NX6-003	ROLLER, 4.0×14.8 B	(32)	—	
• 13	90003-NX6-000	BOLT, flange 10×28	2	2		• 31	91113-NX6-701	ROLLER, 4.0×14.3 B	(32)	(32)	L14.3
• 14	90403-NX6-000	WASHER, 10×30×3.5	2	2		• 32	91114-NX6-003	ROLLER, 4.0×14.8 C	(32)	—	
• 15	91001-KV3-831	BEARING, A. 63/28special	2	2		• 33	91114-NX6-701	ROLLER, 4.0×14.3 C	(32)	(32)	L14.3
• 16	91002-KV3-831	BEARING, B. 63/28special	1	1		• 34	91201-NX6-300	OIL-SEAL, 50×68×6	1	1	
• 17	91005-NX6-003	BEARING, con-rod small end	1	1		• 35	91205-NX6-000	OIL-SEAL, 37×68×6	1	1	
• 18	91005-NX6-701	BEARING, con-rod small end	(1)	1		• 36	91206-NX6-000	OIL-SEAL, 20×68×6	1	1	
• 19	91006-NX6-300	OUTER COMP. crank bearing	1	1		• 37	91301-NX6-003	D-RING, 27.5×30.5×5	1	1	
						• 38	94560-68200	SNAP RING, 68mm	2	2	

Block No.

E-8

Transmission

'97 NSR500V
'98 NSR500V

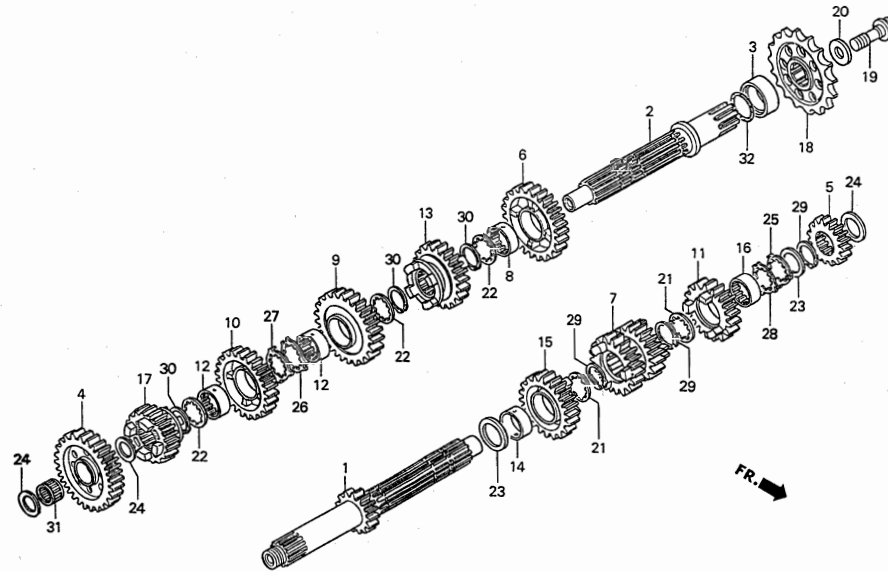

Ref. No.	Part No.	Description	Reqd. No.		Remarks	Ref. No.	Part No.	Description	Reqd. No.		Remarks
			'97	'98					'97	'98	
• 1	23211-NX6-000	SHAFT, main plan-1	1	1	15T	• 8	23435-NX6-000	COLLAR, 28mm	1	—	
•	23212-NX6-000	SHAFT, main plan-2	(1)	(1)	16T	• 9	23451-NX6-000	GEAR, C-3rd plan-1	(1)	—	28T
• 2	23221-NX6-000	SHAFT, counter	1	1		•	23451-NX6-700	GEAR, C-3rd plan-1	(1)	—	28T
• 3	23225-NX6-000	COLLAR, counter shaft	1	1		•	23452-NX6-000	GEAR, C-3rd plan-2	(1)	—	27T
• 4	23411-NX6-000	GEAR, C-1st plan-1	(1)	(1)	32T	•	23452-NX6-700	GEAR, C-3rd plan-2	(1)	—	27T
•	23412-NX6-000	GEAR, C-1st plan-2	(1)	(1)	31T	•	23453-NX6-000	GEAR, C-3rd plan-3	(1)	—	28T
•	23413-NX6-000	GEAR, C-1st plan-3	1	1	30T	•	23453-NX6-700	GEAR, C-3rd plan-3	(1)	—	28T
•	23414-NX6-000	GEAR, C-1st plan-4	(1)	(1)	31T	•	23454-NX6-000	GEAR, C-3rd plan-4	(1)	—	27T
•	23415-NX6-000	GEAR, C-1st plan-5	(1)	(1)	30T	•	23454-NX6-700	GEAR, C-3rd plan-4	(1)	—	27T
• 5	23421-NX6-000	GEAR, M-2nd plan-1	(1)	(1)	17t	•	23455-NX6-000	GEAR, C-3rd plan-5 / C-4th plan-1	(1)	—	27T
•	23422-NX6-000	GEAR, M-2nd plan-2	(1)	(1)	17t	•	23455-NX6-700	GEAR, C-3rd plan-5 / C-4th plan-1	(1)	—	27T
•	23423-NX6-000	GEAR, M-2nd plan-3	(1)	(1)	18t	•	23456-NX6-000	GEAR, C-3rd plan-6 / C-4th plan-2	1	—	26T
•	23424-NX6-000	GEAR, M-2nd plan-4	1	1	18t	•	23456-NX6-700	GEAR, C-3rd plan-6 / C-4th plan-2	1	—	26T
•	23425-NX6-000	GEAR, M-2nd plan-5	(1)	(1)	18t	• 10	23473-NX6-000	GEAR, C-4th plan-3	(1)	—	26T
• 6	23431-NX6-000	GEAR, C-2nd plan-1	(1)	(1)	30T	•	23473-NX6-700	GEAR, C-4th plan-3	(1)	—	26T
•	23432-NX6-000	GEAR, C-2nd plan-2	(1)	(1)	29T	•	23474-NX6-000	GEAR, C-4th plan-4	1	—	25T
•	23433-NX6-000	GEAR, C-2nd plan-3	1	1	28T	•	23474-NX6-700	GEAR, C-4th plan-4	(1)	—	25T
•	23434-NX6-000	GEAR, C-2nd plan-4	(1)	(1)	27T	•	23475-NX6-000	GEAR, C-4th plan-5	(1)	—	24T
• 7	23441-NX6-010	GEAR, M-3rd•4th plan-1	(1)	(1)	18T•20T	•	23475-NX6-700	GEAR, C-4th plan-5	(1)	—	24T
•	23442-NX6-010	GEAR, M-3rd•4th plan-2	(1)	(1)	18T•21T	• 11	23481-NX6-000	GEAR, M-5th plan-1	(1)	(1)	21T
•	23443-NX6-010	GEAR, M-3rd•4th plan-3	(1)	(1)	18T•21T	•	23483-NX6-000	GEAR, M-5th plan-3 / M-6th plan-1	1	1	22T
•	23444-NX6-010	GEAR, M-3rd•4th plan-4	(1)	(1)	19T•20T	•	23484-NX6-000	GEAR, M-5th plan-4 / M-6th plan-3	(1)	(1)	23T
•	23445-NX6-010	GEAR, M-3rd•4th plan-5	(1)	(1)	19T•21T	• 12	23482-MV9-670	COLLAR, spindle 28×31×9	2	2	
•	23446-NX6-010	GEAR, M-3rd•4th plan-6	(1)	(1)	19T•21T						
•	23447-NX6-010	GEAR, M-3rd•4th plan-7	1	1	20T•21T						
•	23448-NX6-010	GEAR, M-3rd•4th plan-8	(1)	(1)	20T•21T						

Block No.

E-8

Transmission

'97 NSR500V

'98 NSR500V

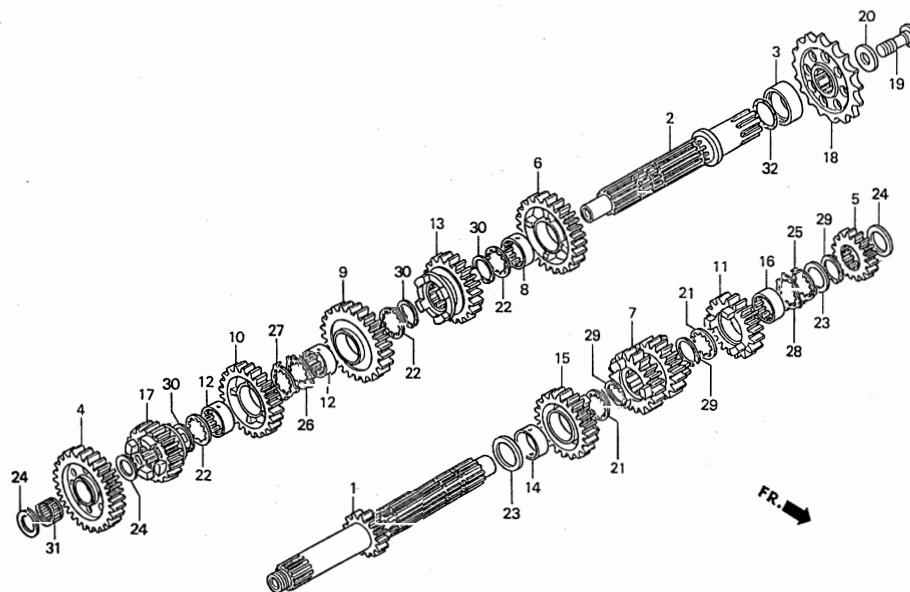

Ref. No.	Part No.	Description	Reqd. No.		Remarks	Ref. No.	Part No.	Description	Reqd. No.		Remarks
			'97	'98					'97	'98	
• 13	23491-NX6-000	GEAR, C-5th plan-1	(1)	—	25T	26	90463-MR7-000	WASHER, spline 28mm	1	1	
•	23491-NX6-700	GEAR, C-5th plan-1	—	(1)	25T	27	90464-MR7-000	WASHER, lock 28mm	1	1	
•	23492-NX6-000	GEAR, C-5th plan-2	(1)	—	24T	28	90465-MR7-000	WASHER, spline 25mm	1	1	
•	23492-NX6-700	GEAR, C-5th plan-2	—	(1)	24T	29	90601-107-000	CIRCLIP, 25mm	3	3	
•	23493-NX6-000	GEAR, C-5th plan-3 / C-6th plan-1	1	—	24T	30	90603-MN4-000	CIRCLIP, 28mm	3	3	
•	23493-NX6-700	GEAR, C-5th plan-3 / C-6th plan-1	—	1	24T						
•	23494-NX6-000	GEAR, C-5th plan-4 / C-6th plan-2	(1)	—	23T	31	91026-MN0-003	BEARING, needle 20×24×11	1	1	
•	23494-NX6-700	GEAR, C-5th plan-4 / C-6th plan-2	—	(1)	23T	• 32	91301-NX6-003	D-RING, 27.5×30.5×5	1	1	
14	23495-MB0-000	COLLAR, 25×12	1	1							
• 15	23504-NX6-000	GEAR, M-6th plan-4	1	1	23T						
•	23505-NX6-000	GEAR, M-6th plan-5	(1)	(1)	24T						
• 16	23512-NX6-000	COLLAR, spline 25×28×12	1	1							
• 17	23514-NX6-000	GEAR, C-6th plan-4	1	—	22T						
•	23514-NX6-700	GEAR, C-6th plan-4	—	1	22T						
• 18	23802-NX6-000	SPROCKET, drive 15T	(1)	(1)							
•	23803-NX6-000	SPROCKET, drive 16T	1	1							
•	23804-NX6-000	SPROCKET, drive 17T	(1)	(1)							
• 19	90007-NX6-000	BOLT, flange 10×42	1	1							
20	90404-KV3-830	WASHER, 10mm	1	1							
21	90451-MR7-000	WASHER, spline 25×31×1.5	2	2							
22	90452-MR7-000	WASHER, spline 28×34×1.5	3	3							
23	90456-MA6-000	WASHER, 25mm	2	2							
24	90461-759-000	SHIM, B. 3rd gear final red	3	3							
25	90462-MR7-000	WASHER, lock 25mm	1	1							

Block No.

E-9

Gearshift fork
Gearshift drum

'97 NSR500V
'98 NSR500V

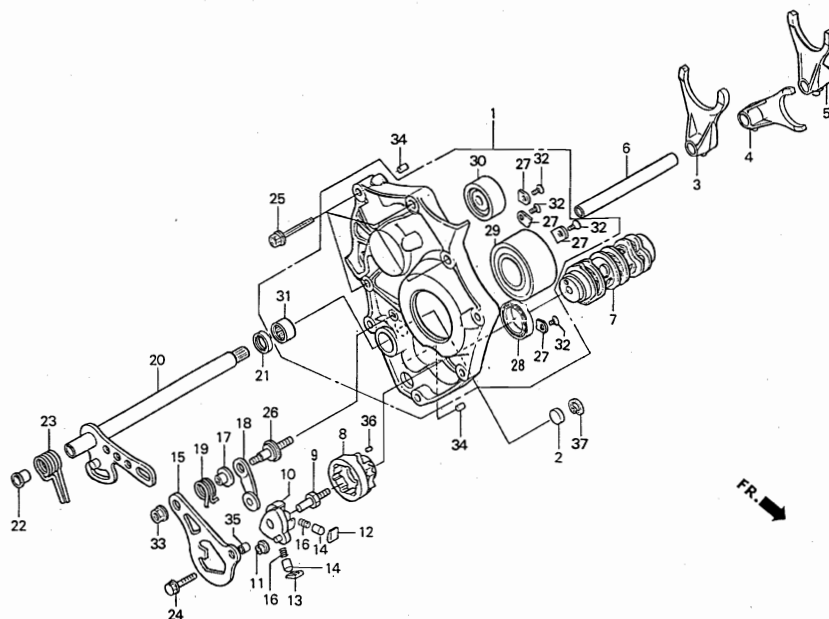

Ref. No.	Part No.	Description	Reqd. No.		Remarks	Ref. No.	Part No.	Description	Reqd. No.		Remarks
			'97	'98					'97	'98	
• 1	11130-NX6-000	HOLDER ASSY. transmission bearing	1	1		• 18	24430-NX6-000	STOPPER COMP. drum	1	—	
• 2	15115-NX6-000	MAGNET, 16×3.5	1	1		•	24430-NX6-700	STOPPER COMP. drum	(1)	1	
• 3	24211-NX6-000	FORK R, gear shift	1	—		• 19	24435-NX6-010	SPRING, drum stopper	1	1	
•	24211-NX6-700	FORK R, gear shift	(1)	1		• 20	24610-NX6-010	SPINDLE COMP. gear shift	1	1	
• 4	24221-NX6-000	FORK C, gear shift	1	—		• 21	24616-NX6-000	COLLAR, shift spindle	1	1	
•	24221-NX6-700	FORK C, gear shift	(1)	1		• 22	24618-NX6-000	CAP, shift spindle	1	1	
• 5	24231-NX6-000	FORK L, gear shift	1	—		• 23	24651-NX6-000	SPRING, shift return	1	1	
•	24231-NX6-700	FORK L, gear shift	(1)	1		24	90004-GHB-660	BOLT, flange NSHF 6×22	1	1	
• 6	24265-NX6-000	SHAFT, shift fork	1	—		• 25	90005-NX6-000	BOLT, flange 7×30	8	8	
•	24265-NX6-700	SHAFT, shift fork	(1)	1		• 26	90013-NX6-000	BOLT, drum stopper	1	—	
• 7	24310-NX6-000	DRUM COMP. gear shift	1	1		•	90013-NX6-700	BOLT, drum stopper	(1)	1	
• 8	24312-NX6-000	CENTER, shift drum	1	1		• 27	90471-NX6-000	STOPPER, bearing 10	4	4	
9	24315-HA0-000	PIN, shifter	1	1		• 28	91007-NX6-003	BEARING, ball 6805LU	1	1	
10	24321-KW6-902	SHIFTER, drum	1	—		• 29	91011-NX6-003	BEARING, ball 5205Z	1	1	
•	24321-NX6-700	SHIFTER, drum	(1)	1		• 30	91022-NX6-003	BEARING, needle 20mm	1	1	
11	24322-MM4-000	COLLAR, drum shifter	1	—		• 31	91023-NX6-003	BEARING, needle 15×21×10	1	1	
•	24322-NX6-700	COLLAR, drum shifter	(1)	1		32	93600-06012-0A	SCREW, flat 6×12	4	4	
• 12	24324-NX6-000	PAWL, A. ratchet 12	1	1		33	94050-06000	NUT, flange 6mm	1	1	
• 13	24325-NX6-000	PAWL, B. ratchet 12.75	1	1		34	94301-06100	DOWEL PIN, 6×10	2	2	
• 14	24326-KBH-901	PLUNGER, pawl	2	2		35	94301-08100	DOWEL PIN, 8×10	1	1	
• 15	24328-NX6-000	PLATE, guide	1	1		36	94303-04065	DOWEL PIN, 4×6.5	1	1	
16	24329-KA3-740	SPRING, pawl plunger	2	2		• 37	94520-16000	CIRCLIP, internal 16	1	1	
• 17	24329-NX6-000	COLLAR, stopper spring	1	—							
•	24329-NX6-700	COLLAR, stopper spring	(1)	1							

Block No.

E-10

Carburetor

'97 NSR500V

'98 NSR500V

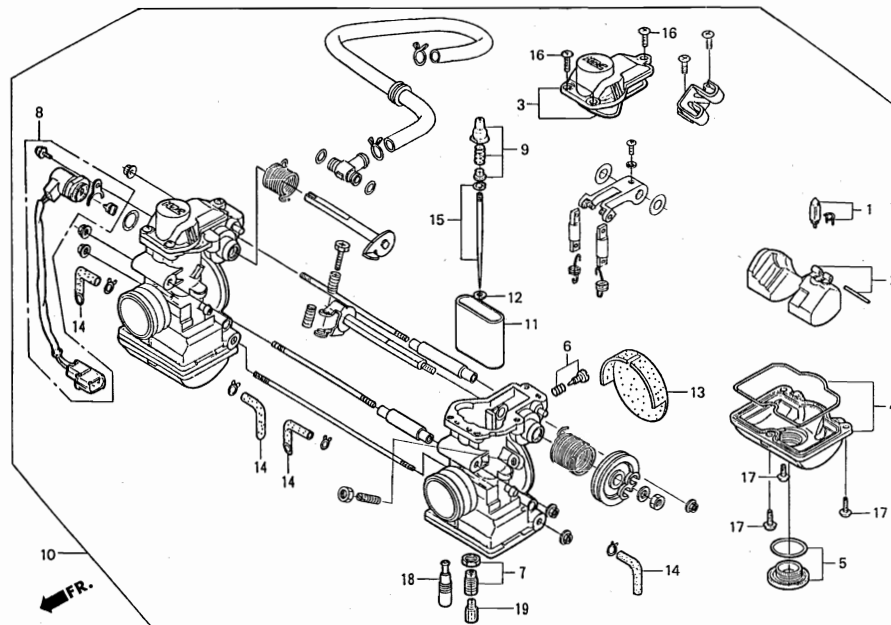

Ref. No.	Part No.	Description	Reqd. No.		Remarks	Ref. No.	Part No.	Description	Reqd. No.		Remarks
			'97	'98					'97	'98	
- 1	16011-NX6-000	VALVE SET. float	2	2		- 15	16209-NX6-000	NEEDLE SET. jet	(2)	(2)	1173/3167/1422
- 2	16013-NX6-000	FLOAT SET	2	2		16	93500-04012-1A	SCREW, pan 4×12	6	6	
- 3	16014-NX6-010	TOP SET	2	2		17	93892-04014-10	SCREW WASHER, 4×14	6	6	
- 4	16015-NX6-000	CHAMBER SET. float	2	2		18	99103-437-0350	JET, slow #35	(2)	(2)	φ 0.7
- 5	16016-NX6-000	BOLT SET. holding	2	2			99103-427-0380	JET, slow #38	(2)	(2)	φ 0.6
- 6	16017-NX6-000	SCREW SET	2	2			99103-437-0380	JET, slow #38	(2)	(2)	φ 0.7
- 7	16041-NX6-000	HOLDER SET. main jet	2	2			99103-427-0400	JET, slow #40	(2)	(2)	φ 0.6
- 8	16060-NX6-000	SENSOR SET. throttle	1	1			99103-437-0400	JET, slow #40	(2)	2	φ 0.7
- 9	16070-NX6-010	PLATE SET. spring	2	2			99103-437-0400	JET, slow #40	(2)	2	φ 0.7
- 10	16100-NX6-020	CARBURETOR ASSY.	1				99103-427-0420	JET, slow #42	2	(2)	φ 0.6
-	16100-NX6-700	CARBURETOR ASSY.	(1)	1			99103-437-0420	JET, slow #42	(2)	(2)	φ 0.7
- 11	16111-NX6-000	VALVE, throttle	2	2	CA 5.0		99103-427-0450	JET, slow #45	(2)	(2)	φ 0.6
-	16112-NX6-000	VALVE, throttle	(2)	(2)	CA 4.5		99103-437-0450	JET, slow #45	(2)	(2)	φ 0.7
-	16113-NX6-000	VALVE, throttle	(2)	(2)	CA 5.5		99103-427-0480	JET, slow #48	(2)	(2)	φ 0.6
- 12	16178-NX6-010	WASHER, plain	2	2		19	99113-GHB-1600	JET, main #160	(2)	(2)	
- 13	16196-NX6-010	CAP	2	2			99113-GHB-1620	JET, main #162	(2)	(2)	
14	16199-GN2-671	TUBE, air vent	4	4			99113-GHB-1650	JET, main #165	(2)	(2)	
- 15	16201-NX6-010	NEEDLE SET. jet	2	2	1169/3167/1422		99113-GHB-1680	JET, main #168	(2)	(2)	
-	16202-NX6-010	NEEDLE SET. jet	(2)	(2)	1165/3167/1422		99113-GHB-1700	JET, main #170	(2)	(2)	
-	16203-NX6-010	NEEDLE SET. jet	(2)	(2)	1166/3167/1422		99113-GHB-1720	JET, main #172	(2)	(2)	
-	16204-NX6-010	NEEDLE SET. jet	(2)	(2)	1167/3167/1422		99113-GHB-1750	JET, main #175	(2)	(2)	
-	16205-NX6-010	NEEDLE SET. jet	(2)	(2)	1168/3167/1422		99113-GHB-1780	JET, main #178	(2)	(2)	
-	16206-NX6-010	NEEDLE SET. jet	(2)	(2)	1170/3167/1422		99113-GHB-1800	JET, main #180	(2)	(2)	
-	16207-NX6-010	NEEDLE SET. jet	(2)	(2)	1171/3167/1422		99113-GHB-1820	JET, main #182	(2)	(2)	
-	16208-NX6-000	NEEDLE SET. jet	(2)	(2)	1172/3167/1422		99113-GHB-1850	JET, main #185	(2)	(2)	
							99113-GHB-1880	JET, main #188	(2)	(2)	=99101-357-1880
							99113-GHB-1900	JET, main #190	(2)	(2)	=99101-357-1900

Block No.

E-10

Carburetor

'97 NSR500V
'98 NSR500V

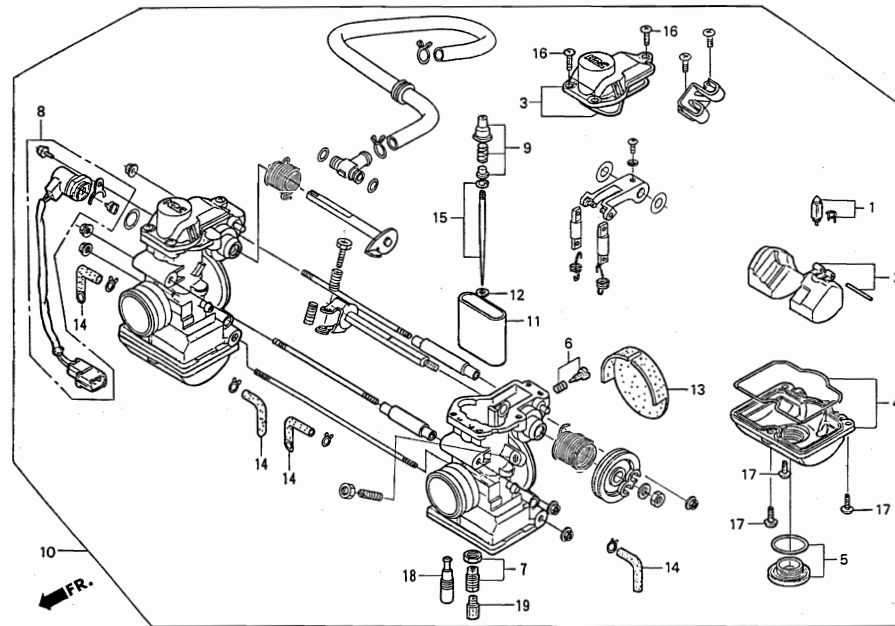

Ref. No.	Part No.	Description	Reqd. No.		Remarks	Ref. No.	Part No.	Description	Reqd. No.		Remarks
			'97	'98					'97	'98	
19	99113-GHB-1920	JET, main #192	(2)	(2)	= 99101-357-1920						
	99113-GHB-1950	JET, main #195	(2)	(2)	= 99101-357-1950						
	99113-GHB-1980	JET, main #198	(2)	(2)	= 99101-357-1980						
	99113-GHB-2000	JET, main #200	1	1	= 99101-357-2000						
•	99113-GHB-2050	JET, main #205	(2)	(2)	= 99101-357-2050						
•	99113-GHB-2100	JET, main #210	(2)	(2)	= 99101-357-2100						
•	99113-GHB-2150	JET, main #215	(2)	(2)	= 99101-357-2150						
•	99113-GHB-2200	JET, main #220	1	1	= 99101-357-2200						
•	99113-GHB-2250	JET, main #225	(2)	(2)							
•	99113-GHB-2300	JET, main #230	(2)	(2)							

Block No.

F-1

Servo motor • Meter
Meter panel

'97 NSR500V
'98 NSR500V

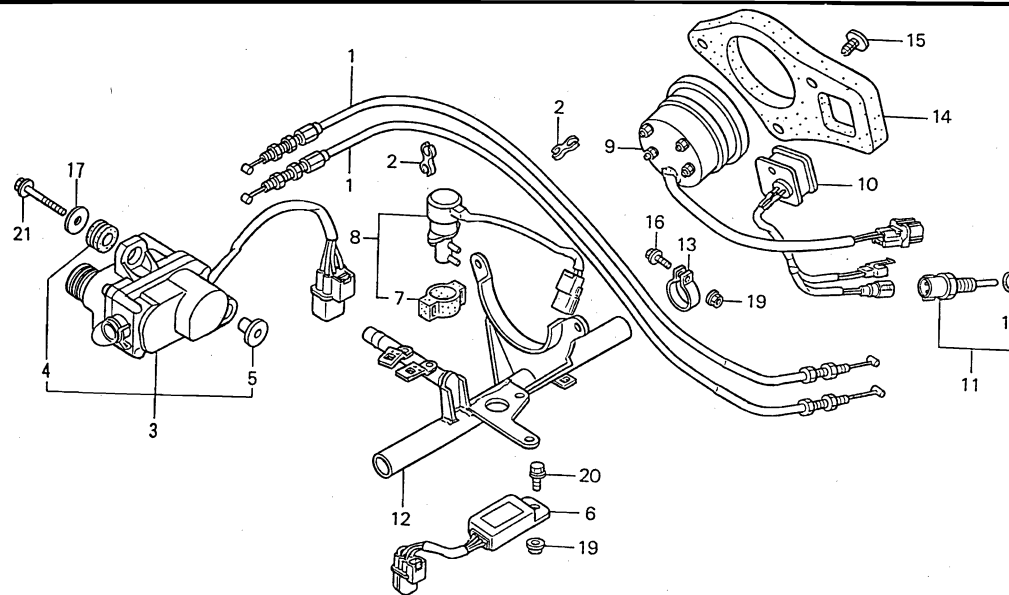

FR.

Ref. No.	Part No.	Description	Reqd. No.		Remarks	Ref. No.	Part No.	Description	Reqd. No.		Remarks
			'97	'98					'97	'98	
• 1	17810-NX6-000	CABLE, control	2	2							
• 2	17955-NF5-750	HOLDER, cable	2	2							
• 3	31420-NX6-000	MOTOR ASSY. servo	1	1							
• 4	31424-NX6-000	RUBBER, servo	2	2							
• 5	31426-NX6-000	COLLAR, servo	2	2							
• 6	31600-NX6-003	REGULATOR RECTIFIER COMP.	1	1							
7	36172-KV3-701	SUSPENSION, solenoid valve	1	1							
• 8	36190-NX6-003	VALVE ASSY. ram solenoid	1	1							
• 9	37250-NX6-003	TACHOMETER ASSY.	1	1							
• 10	37460-NX4-701	METER ASSY. water temp	1	1							
• 11	37870-NF4-611	SENSOR ASSY. T. W.	1	1							
• 12	50810-NX6-000	STAY COMP. front center cowl	1	1							
• 13	50811-NF4-770	BAND, D25	1	1							
• 14	50815-NX4-000	PANEL, meter	1	1							
• 15	50816-NX4-000	CLIP, Xmas tree	3	3							
16	90002-GHB-690	BOLT, flange SHF 6×32	1	1							
17	90403-KA3-830	WASHER, radiator mount	2	2							
18	91307-PK2-005	O-RING,	1	1							
19	94050-06000	NUT, flange 6mm	2	2							
20	96001-06012-00	BOLT, flange SH 6×12	1	1							
21	96001-06025-00	BOLT, flange SH 6×25	2	2							

Block No.

F-2

**Cable-Switch
Handlebar**

'97 NSR500V
'98 NSR500V

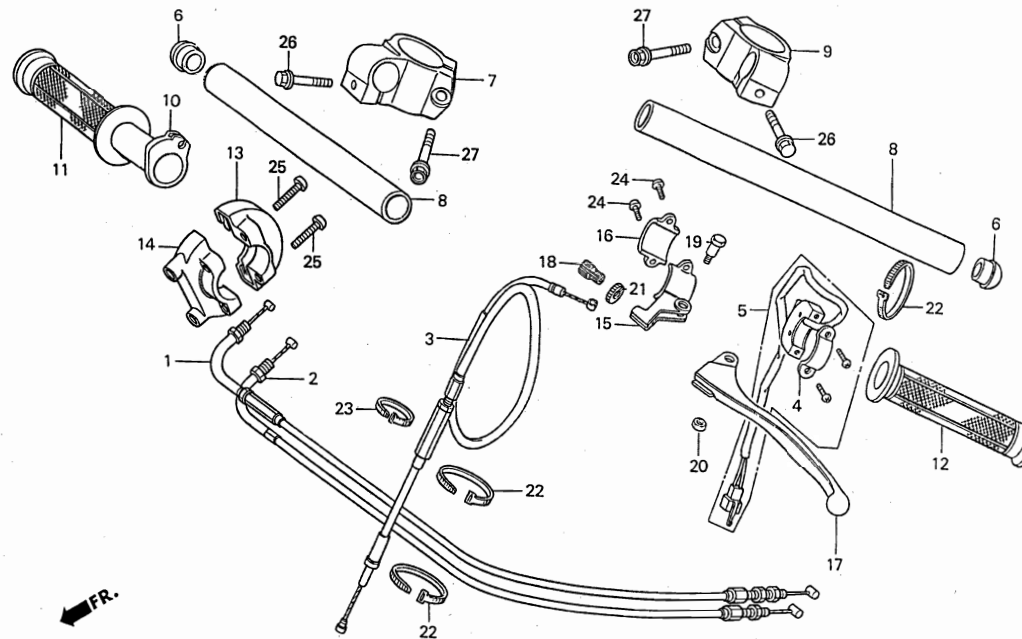

Ref. No.	Part No.	Description	Reqd. No.		Remarks	Ref. No.	Part No.	Description	Reqd. No.		Remarks
			'97	'98					'97	'98	
- 1	17910-NX6-000	CABLE COMP. throttle pull	1	1		24	93500-05016-0A	SCREW, pan 5×16	2	2	
- 2	17920-NX6-000	CABLE COMP. throttle back	1	1		25	93500-05020-0G	SCREW, pan 5×20	2	2	
- 3	22870-NX6-000	CABLE COMP. clutch	1	1		26	96001-06022-00	BOLT, flange SH 6×22	2	2	
4	35132-KR5-013	PLATE, set	1	1		27	96500-08035-00	BOLT, flange DR 8×35	2	2	
- 5	35300-NX6-003	SWITCH ASSY. main	1	1							
- 6	53105-NF4-770	CAP, handle pipe	2	2							
- 7	53110-NL5-700	HOLDER, R. handle	1	1							
- 8	53111-NX6-000	PIPE, handle	2	2							
- 9	53120-NL5-700	HOLDER, L. handle	1	1							
- 10	53141-WT7-000	PIPE, throttle grip	1	1							
11	53165-KT8-710	GRIP, R. handle	1	1							
12	53166-KT8-710	GRIP, L. handle	1	1							
- 13	53167-NX6-000	HOUSING, upper throttle	1	1							
14	53168-KV3-701	HOUSING, under throttle	1	1							
15	53172-430-003	BRACKET, L. handle lever	1	1							
16	53173-376-000	HOLDER, lever bracket	1	1							
17	53178-399-700	LEVER, L. steering handle	1	1							
18	53192-KA4-710	BOLT, wire adjust	1	1							
19	90114-310-000	BOLT, handle lever pivot	1	1							
- 20	90302-NX5-000	U-NUT, hex 6mm	1	1							
21	90321-KF0-000	NUT, fixing	1	1							
- 22	90651-NC8-000	TIE-WRAP, 3.6×281	3	3							
- 23	90652-ND5-000	TIE-WRAP, 2.4×92	1	1							

Block No.

F-3

Front brake caliper
Front brake
mastercylinder
'97 NSR500V
'98 NSR500V

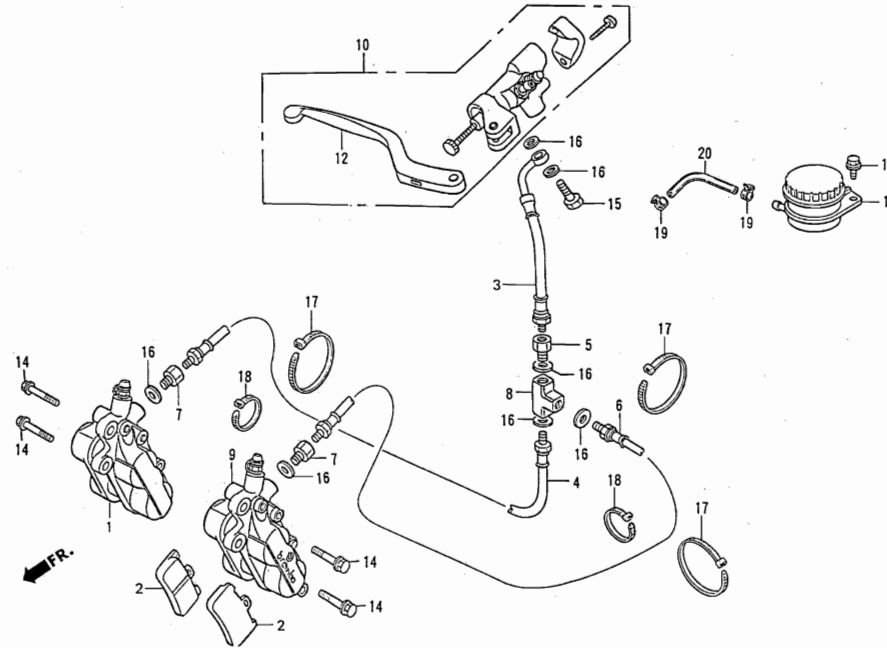

Ref. No.	Part No.	Description	Reqd. No.		Remarks	Ref. No.	Part No.	Description	Reqd. No.		Remarks
			'97	'98					'97	'98	
1		CALIPER ASSY. R.	1	1	BREMBO No sale by HRC	19	95002-40850-08	CLAMP, D 8.5 tube	2	2	
2		PAD, front CC.	4	4	BREMBO No sale by HRC	20	95003-11015-60	V-TUBE, 5×9×150	1	1	Available length IN only
		PAD, front (wet)	(4)	(4)	BREMBO No sale by HRC						
- 3	45125-NX6-000	HOSE, front brake A	1	1							
- 4	45126-NX6-000	HOSE, R. front brake B	1	1							
5	45127-KZ4-003	JOINT, brake hose	1	1							
- 6	45127-NX6-000	HOSE, L. front brake B	1	1							
- 7	45128-NX6-000	JOINT, brake hose	2	2							
- 8	45129-NL5-700	JOINT, 3 way	1	1							
9		CALIPER ASSY. L.	1	1	BREMBO No sale by HRC						
- 10	45500-NL5-701	MASTER CYLINDER ASSY. BRL18	1	1							
11		CUP ASSY. front master cylinder	1	1	BREMBO No sale by HRC						
- 12	53160-NL5-701	LEVER, front brake L18P	1	1							
13	90108-GK1-000	BOLT, flange SH 6×12	1	1							
- 14	90111-NX4-000	BOLT, flange 10×31	4	4							
- 15	90145-NX5-004	OIL BOLT, 10×19	1	1							
16	90601-ZE1-000	WASHER, plug drain 10mm	7	7							
- 17	90651-NC8-000	TIE-WRAP, 3.6×281	3	3							
- 18	90652-ND5-000	TIE-WRAP, 2.4×92	2	2							

Block No.

F-4

Steering stem
Steering damper
Front fender

'97 NSR500V

'98 NSR500V

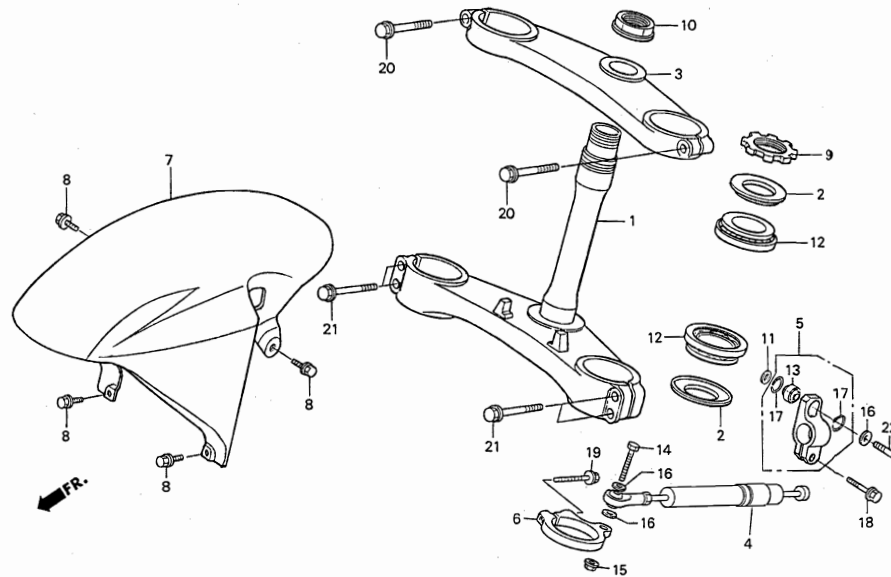

Ref. No.	Part No.	Description	Reqd. No.		Remarks	Ref. No.	Part No.	Description	Reqd. No.		Remarks
			'97	'98					'97	'98	
• 1	53200-NX6-000	STEM COMP. steering 30	1	1		21	96500-08035-00	BOLT, flange DR 8×35	4	4	
•	53200-NX6-305	STEM COMP. steering 32.5	(1)	(1)		22	96700-08028-10	BOLT, socket 8×28	1	1	
•	53200-NX6-306	STEM COMP. steering 27.5	(1)	(1)							
2	53214-MR7-003	DUST SEAL, steering head	2	2							
• 3	53230-NX6-000	BRIDGE, fork top 30	1	1							
•	53231-NX6-000	BRIDGE, fork top 32.5	(1)	(1)							
•	53232-NX6-000	BRIDGE, fork top 27.5	(1)	(1)							
• 4	53700-NF5-762	DAMPER ASSY. steering	1	1							
• 5	53705-NF5-760	HOLDER ASSY. steering damper	1	1							
• 6	53710-NF5-611	STAY, steering damper	1	1							
• 7	61100-NX6-000	FENDER COMP. front	1	1							
8	90108-GK1-000	BOLT, flange SH 6×12	4	4							
9	90302-MR7-000	THREAD, B. top	1	1							
• 10	90302-NF5-760	NUT, steering stem	1	1							
11	90485-GB4-790	WASHER, 8mm	1	1							
12	91016-MR7-003	BEARING, head pipe	2	2							
• 13	91060-NL0-003	BEARING, spherical 8mm	1	1							
14	92101-08032-0A	BOLT, hex 8×32	1	1							
15	94050-08000	NUT, flange 8mm	1	1							
16	94102-08000	WASHER, plain 8mm	3	3							
17	94601-17000	CLIP, piston pin 17mm	2	2							
18	96001-06028-00	BOLT, flange SH 6×28	1	1							
19	96001-06035-00	BOLT, flange SH 6×35	1	1							
20	96400-08045-00	BOLT, flange DR 8×45	2	2							

Block No.

F-5

Front wheel

'97 NSR500V

'98 NSR500V

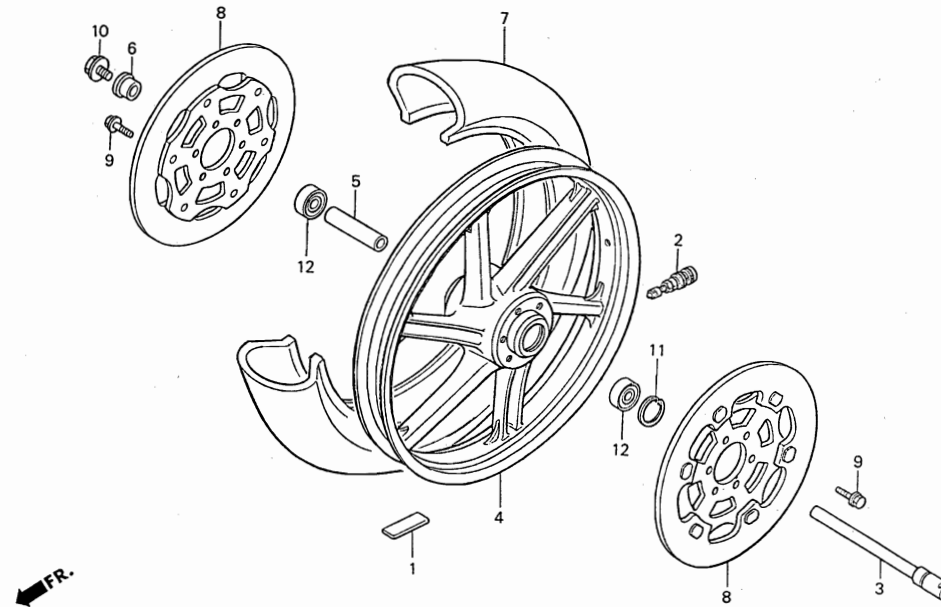

Ref. No.	Part No.	Description	Reqd. No.		Remarks	Ref. No.	Part No.	Description	Reqd. No.		Remarks
			'97	'98					'97	'98	
- 1	42720-NC8-000	WEIGHT, balancer 10G	N	N							
2	42753-ML7-004	VALVE, rim (DUN)	1	1							
- 3	44300-NF5-610	AXLE ASSY. front wheel	1	1							
4		WHEEL, front 3.50-17	1	1	MARCHESINI No sale by HRC						
- 5	44620-ND5-750	COLLAR, front axle center	1	1							
- 6	44621-NF5-750	COLLAR, front wheel side	1	1							
7		TIRE, front 12/60-17	1	1	MICHELIN No sale by HRC						
8		DISK ASSY. front(CC).....	2	2	BREMBO No sale by HRC						
		DISK ASSY. front(WET)	(2)	(2)	BREMBO No sale by HRC						
9	90003-MC7-000	BOLT, flange 6x20	12	12							
10	90305-ML7-000	BOLT, front axle	1	1							
11	94520-42000	CIRCLIP, internal 42	1	1							
12	96150-60040-10	BEARING, ball radial 6004	2	2							

Block No.

F-6

Rear brake caliper
Rear brake
master cylinder

'97 NSR500V
'98 NSR500V

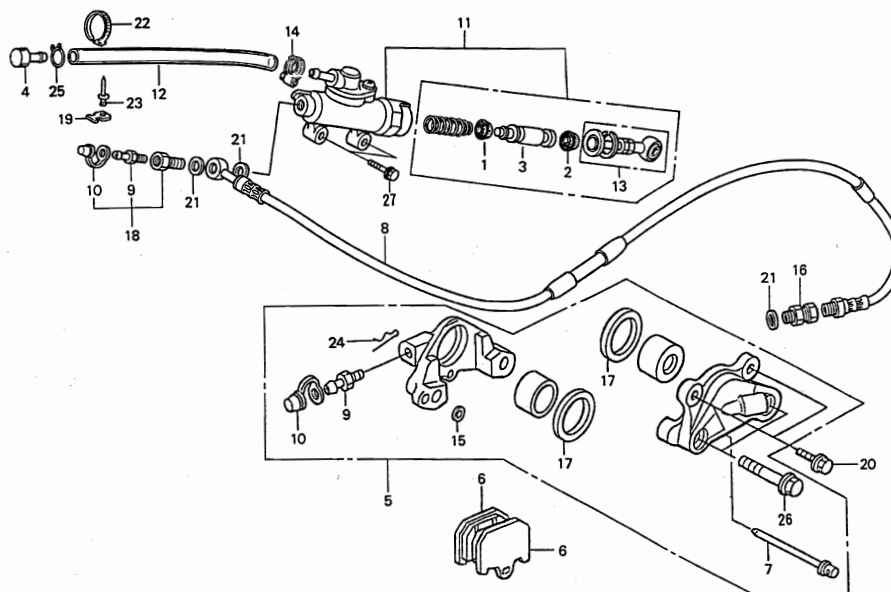

Ref. No.	Part No.	Description	Reqd. No.		Remarks	Ref. No.	Part No.	Description	Reqd. No.		Remarks
			'97	'98					'97	'98	
- 1	04601-ND5-760	CUP, primary	1	1	(=45514-186-006)	24	94251-05000	PIN, lock 5mm	1	1	
- 2	04602-ND5-760	CUP, secondary	1	1	(=45542-471-831)	25	95002-02130	CLIP, B12.5 tube	1	1	
- 3	04603-NF4-770	PISTON, rear	1	1	(=43502-MJ6-006)	26	95701-08040-00	BOLT, flange 8×40	2	2	
4	17370-419-700	PLUG, breather tube	1	1		27	96001-06018-00	BOLT, flange SH 6×18	2	2	
- 5	43100-NL5-701	CALIPER ASSY. rear	1	1							
- 6	43105-NL5-700	PAD COMP. rear (X95A)	2	2							
- 7	43215-NL5-701	PIN, hanger rear	1	1							
- 8	43310-NX6-000	HOSE, rear brake	1	1							
9	43352-568-003	SCREW, bleeder	2	2							
10	43353-461-771	CAP, bleeder	2	2							
- 11	43500-NX6-000	MASTER CYLINDER ASSY. rear	1	1							
- 12	43503-NF4-000	V-TUBE, 9×13×240	1	1							
- 13	43504-NF4-770	ROD ASSY.	1	1							
- 14	43541-ND5-750	CLAMP,	1	1							
15	45103-MR7-006	SEAL, joint	1	1							
16	45127-KZ4-003	JOINT, brake hose	1	1							
- 17	45209-KV3-951	SEAL, piston	2	2							
- 18	45530-NF4-650	BOLT ASSY. oil bleeder	1	1							
- 19	52161-NF5-710	HOSE BASE, saddle	1	1							
- 20	90120-NL5-700	BOLT, flange 7×20	2	2							
21	90601-ZE1-000	WASHER, plug drain 10mm	3	3							
- 22	90651-NC8-000	TIE-WRAP, 3.6×281	1	1							
- 23	91080-NF5-710	RIVET, 4.0×8.6	1	1							

Block No.

F-7

Rear wheel

'97 NSR500V

'98 NSR500V

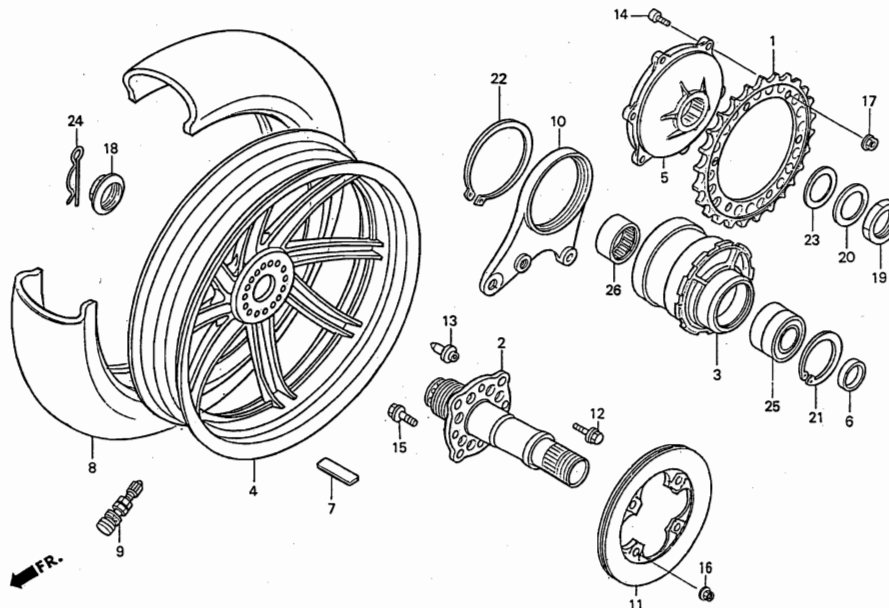

Ref. No.	Part No.	Description	Reqd. No. '97	Reqd. No. '98	Remarks	Ref. No.	Part No.	Description	Reqd. No. '97	Reqd. No. '98	Remarks
- 1	41235-NX6-000	SPROCKET, final 35	(1)	(1)		- 18	90309-NL5-700	NUT, center lock	1	1	
-	41236-NX6-000	SPROCKET, final 36	(1)	(1)		- 19	90315-MR7-000	NUT, M38×1.5	1	1	
-	41237-NX6-000	SPROCKET, final 37	1	1		- 20	90501-MR7-003	WASHER, conical spring 38	1	1	
-	41238-NX6-000	SPROCKET, final 38	(1)	(1)		- 21	90651-ML0-731	CIRCLIP, internal 62	1	1	
-	41239-NX6-000	SPROCKET, final 39	(1)	(1)		- 22	90652-NX5-000	CIRCLIP, external 80	1	1	
-	41240-NX6-000	SPROCKET, final 40	(1)	(1)		- 23	90653-MR7-000	SIM, driven flange	1	1	
- 2	42301-NX6-000	HUB, rear axle	1	1		- 24	90751-NL5-700	PIN, lock 42mm	1	1	
- 3	42510-NX6-700	BODY, eccentric	1	1		- 25	91061-ML0-731	BEARING, ball radial 6908LUX2	1	1	
4		WHEEL, rear 5.75-17	1	1	MARCHESINI No sale by HRC	- 26	91062-NX5-003	BEARING, needle	1	1	
- 5	42615-NX6-000	FLANGE, driven	1	1							
- 6	42617-NX6-000	COLLAR, rear axle	1	1							
- 7	42720-NC8-000	WEIGHT, balancer 10G	N	N							
8		TIRE, rear 17/63-17			MICHELIN No sale by HRC						
9	42753-ML7-004	VALVE, rim (DUN)	1	1							
- 10	43110-NX6-000	BRACKET, rear caliper	1	1							
- 11	43121-NL5-700	DISK, rear brake	1	1							
12	90113-MR7-000	BOLT, drive pin	4	4							
13	90114-MW4-850	PIN, drive	4	4							
- 14	90120-NX5-000	BOLT, SPROCKET	6	6							
- 15	90122-NX6-000	BOLT, socket 13	4	4							
- 16	90302-NX5-000	U-NUT, hex 6mm	4	4							
17	90309-428-731	NUT, flange 8mm	6	6							

Block No.

F-8

Fuel tank

'97 NSR500V

'98 NSR500V

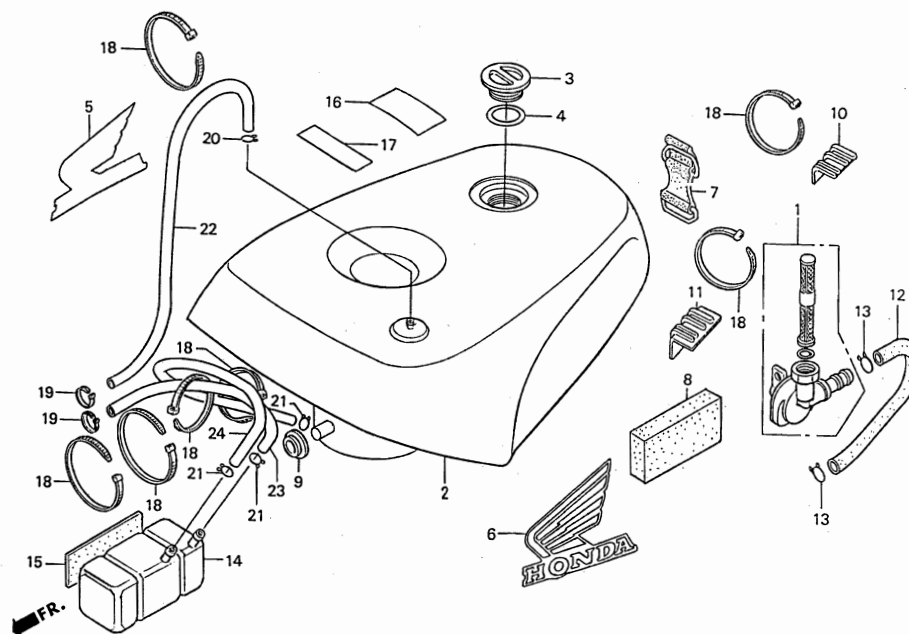

Ref. No.	Part No.	Description	Reqd. No.		Remarks	Ref. No.	Part No.	Description	Reqd. No.		Remarks
			'97	'98					'97	'98	
- 1	16950-NX6-000	COCK ASSY. fuel	1	1		- 22	95003-10045-31	V-TUBE, 5×8×450	1	1	Available length 1M only
- 2	17510-NX6-010	TANK COMP. fuel	1	—		- 23	95003-19025-31	V-TUBE, 7×11×250	1	1	Available length 1M only
-	17510-NX6-700	TANK COMP. fuel	(1)	1		- 24	95003-19052-31	V-TUBE, 7×11×520	1	1	Available length 1M only
- 3	17511-NX5-770	CAP, fuel tank	1	1							
- 4	17515-NX5-770	PACKING, fuel cap	1	1							
- 5	17516-NF4-610	WING MARK, R. side	1	1							
- 6	17517-NF4-610	WING MARK, L. side	1	1							
- 7	17521-NF5-950	BAND, fuel tank	1	1							
- 8	17522-NF5-690	SPONGE, baffle	7	7							
- 9	17525-NX6-000	RUBBER, fuel tank mount front	1	1							
- 10	17527-NC8-000	RUBBER, side fuel tank mount	(2)	2							
- 11	17528-NF4-000	RUBBER, fuel tank mount B	2	2							
- 12	17701-NX6-000	TUBE, fuel	1	1							
13	17724-102-700	CLIP, sub tank hose	2	2							
- 14	19601-NX6-000	TANK, catch	1	1							
15	50383-HC4-750	RUBBER, battery rear	1	1							
- 16	87208-NC2-000	MARK, caution	1	1							
17	87560-357-671	MARK, caution	1	1							
- 18	90651-NC8-000	TIE-WRAP, 3. 6×281	7	9							
- 19	90652-ND5-000	TIE-WRAP, 2. 4×92	2	2							
20	95002-45000	CLIP, C8 tube	1	1							
21	95002-80000	CLIP, C12 tube	3	3							

Block No.

F-9

Carburetor box

'97 NSR500V

'98 NSR500V

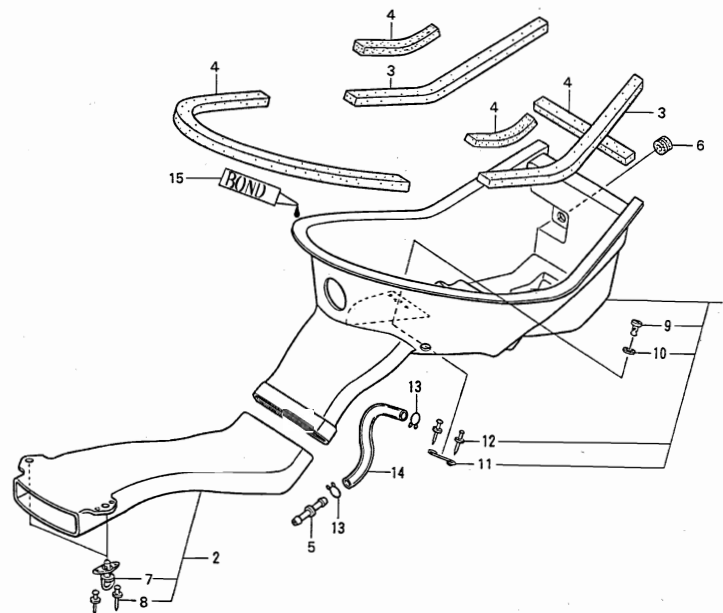

Ref. No.	Part No.	Description	Reqd. No.		Remarks	Ref. No.	Part No.	Description	Reqd. No.		Remarks
			'97	'98					'97	'98	
- 1	17200-NX6-000	BOX, induction	1	1							
- 2	17210-NX6-000	DUCT, air	1	1							
- 3	17220-NX6-000	SEAL, box	1	—							
- 4	17221-NX6-000	SEAL, box S	2	—							
-	17220-NX6-700	SEAL, box	(5)	5							
5	17359-419-670	JOINT, breather tube	1	1							
6	53111-HE0-000	GROMMET, B. steering	1	1							
- 7	90655-NX6-000	STUD, fastener 45	2	2							
- 8	90657-NX6-000	RIVET, 2.4×8.9 flat	4	4							
- 9	90754-NX5-770	STUD, fastener 30	3	3							
- 10	90755-NX5-770	GROMMET, fastener	3	3							
- 11	90756-NX5-770	SPRING, fastener	3	3							
- 12	91082-NF5-000	BLIND RIVET,	6	6							
13	95002-80000	CLIP, C12 tube	2	2							
- 14	95003-19018-31	V-TUBE, 7×11×180	1	1	Available length 1M only						
15		BOND• ARON ALPHA #903P3 • CYANOLIT #903P3 (OR EQUIVALENT)	1	1	No sale by HRC						

Block No.

F-10

Expansion chamber

'97 NSR500V

'98 NSR500V

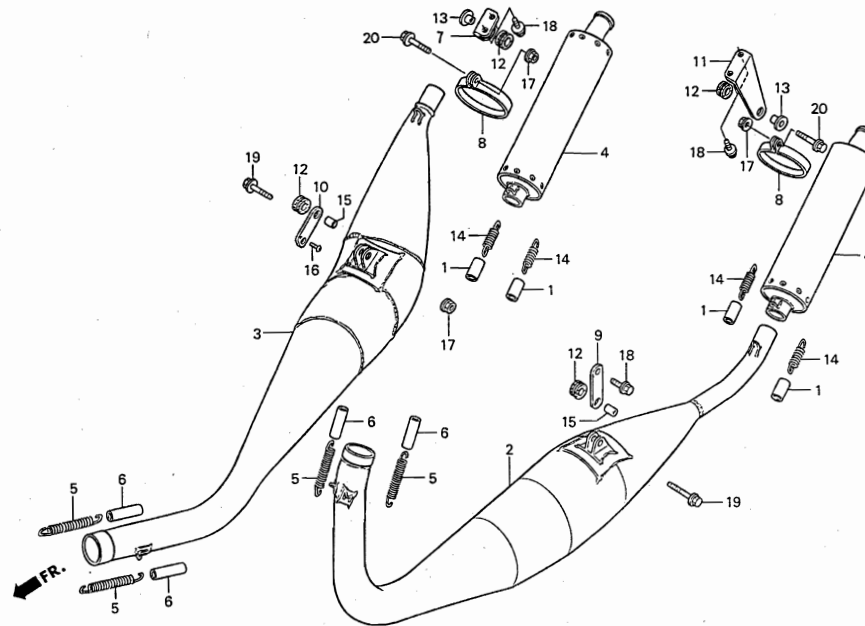

Ref. No.	Part No.	Description	Reqd. No.		Remarks	Ref. No.	Part No.	Description	Reqd. No.		Remarks
			'97	'98					'97	'98	
1	12107-MT7-000	RUBBER, support	4	4							
2	18310-NX6-000	EXPANSION CHAMBER COMP. No. 1	1	—							
3	18310-NX6-700	EXPANSION CHAMBER COMP. No. 1	—	1							
3	18320-NX6-000	EXPANSION CHAMBER COMP. No. 2	1	—							
3	18320-NX6-700	EXPANSION CHAMBER COMP. No. 2	—	1							
4	18330-NX6-000	SILENCER COMP.	2	2							
5	18332-KS6-000	SPRING, exhaust pipe	4	4							
6	18333-ND4-760	TUBE, spring	4	4							
7	18370-NX6-000	STAY, R. silencer	1	1							
8	18371-NX6-000	BAND, silencer stay	2	2							
9	18373-NX6-000	STAY, chamber	1	1							
10	18374-NX6-000	STAY, R. chamber	1	1							
11	18380-NX6-000	STAY, L. silencer	1	1							
12	19051-KA3-830	RUBBER, radiator mount	4	4							
13	19052-KA3-830	COLLAR, radiator mount	2	2							
14	50222-HB5-000	SPRING, lever set	4	4							
15	80108-028-000	COLLAR, fender rear	2	2							
16	93500-03008-0A	SCREW, pan 3×8	1	1							
17	94050-06000	NUT, flange 6mm	3	3							
18	96001-06012-00	BOLT, flange SH 6×12	5	5							
19	96001-06022-00	BOLT, flange SH 6×22	2	2							
20	96001-06025-00	BOLT, flange SH 6×25	2	2							

Block No.

F-11

**Gearshift pedal
Footpeg**

'97 NSR500V
'98 NSR500V

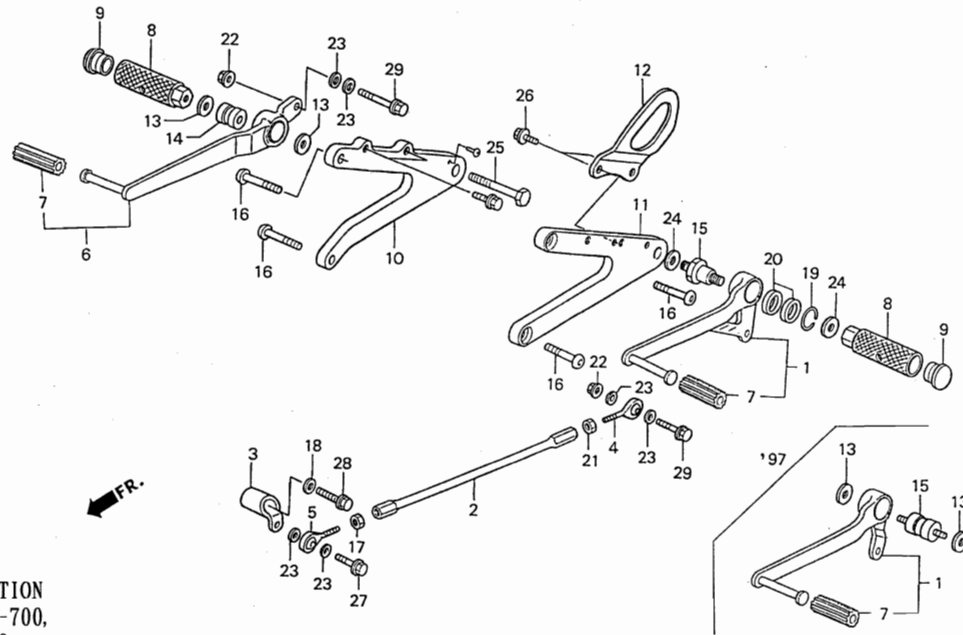

NOTE: Ref No. 1, 3, 15, 19, 20, 24.
CAN BE APPLY FOR TYPE '97 IN CASE OF COMBINATION
WITH 24700-NX6-700, 24710-NX6-700, 50643-NX6-700,
90613-PF4-300, 91058-NX6-700, AND 94101-08000.

Ref. No.	Part No.	Description	Reqd. No.		Remarks	Ref. No.	Part No.	Description	Reqd. No.		Remarks
			'97	'98					'97	'98	
- 1	24700-NF4-780	PEDAL COMP. change	1	—		21	94001-06200-0S	NUT, hex 6mm	1	1	
-	24700-NX6-700	PEDAL COMP. change	(1)	1	NOTE	22	94050-06000	NUT, flange 6mm	2	2	
- 2	24706-NX6-000	BAR, change	1	1		23	94101-06000	WASHER, plain 6mm	6	6	
- 3	24710-NX6-000	ARM, change	1	—		24	94101-08000	WASHER, plain 8mm	(2)	2	NOTE
-	24710-NX6-700	ARM, change	(1)	1	NOTE	25	95801-08045-00	BOLT, flange 8×45	1	1	
- 4	24711-NC8-000	ROD END, 6mm A	1	1		26	96001-06012-00	BOLT, flange SH 6×12	2	2	
- 5	24712-NC8-000	ROD END, 6mm B	1	1		27	96001-06018-00	BOLT, flange SH 6×18	1	1	
- 6	46500-NF4-780	PEDAL COMP. brake	1	1		28	96001-06020-00	BOLT, flange SH 6×20	1	1	
- 7	46501-ND4-750	RUBBER, pedal	2	2		29	96001-06025-00	BOLT, flange SH 6×25	2	2	
- 8	50610-NL5-760	ARM, step	2	2							
- 9	50612-NL5-760	END, step arm	2	2							
- 10	50630-NX6-000	HOLDER, R. step	1	1							
- 11	50640-NX6-000	HOLDER, L. step	1	1							
- 12	50641-NF5-950	PLATE, foot guard	1	1							
- 13	50642-NF4-770	WASHER, 8.2mm	4	2							
- 14	50643-NL5-760	COLLAR, 16×8.2	1	1							
- 15	50643-NX4-770	BOSS, pedal pivot	1	—							
-	50643-NX6-700	BOSS, pedal pivot	(1)	1	NOTE						
- 16	90178-NC8-000	SCREW, 8×22	4	4							
	90201-KV3-700	NUT, tie-rod B	1	1							
	90453-752-830	WASHER, 6mm	1	1							
	90613-PF4-300	SNAP RING, 26mm.	(1)	1	NOTE						
- 20	91058-NX6-700	BEARING, ball radial 15×24×5	(2)	2	NOTE						

Block No.

F-12

Swingarm

'97 NSR500V

'98 NSR500V

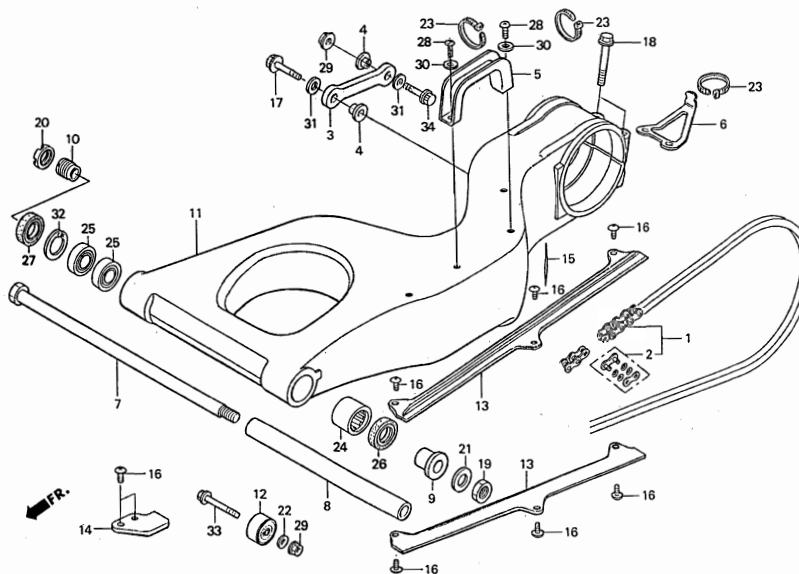

Ref. No.	Part No.	Description	Reqd. No.	'97	'98	Remarks	Ref. No.	Part No.	Description	Reqd. No.	'97	'98	Remarks
- 1	40530-NX6-013	CHAIN, drive	1	1			- 23	90651-NC8-000	TIE-WRAP, 3. 6×281	3	3		
- 2	40531-NX6-013	JOINT, drive chain	1	1			24	91071-MR7-003	BEARING, needle	1	1		
- 3	43111-NX6-000	ROD, rear brake torque	1	1			25	91072-MR7-003	BEARING, ball radial 20×37×9	2	2		
- 4	43112-NX6-000	COLLAR, torque rod	2	2			26	91202-MR7-003	DUST SEAL, 28×37×4	1	1		
- 5	43150-NX6-000	CLAMPER, brake hose	1	1			27	91214-MR7-003	DUST SEAL, 26×37×5	1	1		
- 6	43160-NX6-000	STAY, rear brake hose	1	1			28	93500-03008-0A	SCREW, pan 3×8	2	2		
- 7	52101-NX6-000	BOLT, swingarm pivot	1	1			29	94050-08000	NUT, flange 8mm	2	2		
- 8	52102-NX6-000	COLLAR, swingarm pivot	1	1			30	94101-03000	WASHER, plain 3mm	2	2		
- 9	52106-NX4-000	COLLAR, B. pivot	1	1			31	94102-08000	WASHER, plain 8mm	2	2		
- 10	52109-NX4-000	BOLT, adjust pivot	1	1			32	94520-37000	CIRCLIP, internal 37	1	1		
- 11	52110-NX6-000	SWINGARM,	1	1			33	95801-08045-00	BOLT, flange 8×45	1	1		
12	52158-KA3-831	ROLLER COMP. chain tensioner	1	1			34	96500-08025-00	BOLT, flange DR 8×25	1	1		
- 13	52170-NX5-000	SLIDER, chain	2	2									
- 14	52175-NX6-000	SLIDER, chain A	1										
-	52175-NX6-700	SLIDER, chain A		1									
15	87521-ML0-731	LABEL, swingarm	1	1									
16	90101-692-000	SCREW, truss G-box	8	8									
- 17	90108-NF4-000	BOLT, flange 8×28	1	1									
- 18	90152-NX6-000	BOLT, flange 10×55	2	2									
19	90305-KZ4-891	U-NUT, 18mm	1	1									
- 20	90355-NX4-000	NUT, swingarm pivot	1	1									
21	90401-KZ4-890	WASHER, 18×32×2	1	1									
22	90501-399-880	WASHER, plain 8mm	1	1									

Block No.

F-13

Shock absorber
(Front fork)
(Rear cushion)

'97 NSR500V
'98 NSR500V

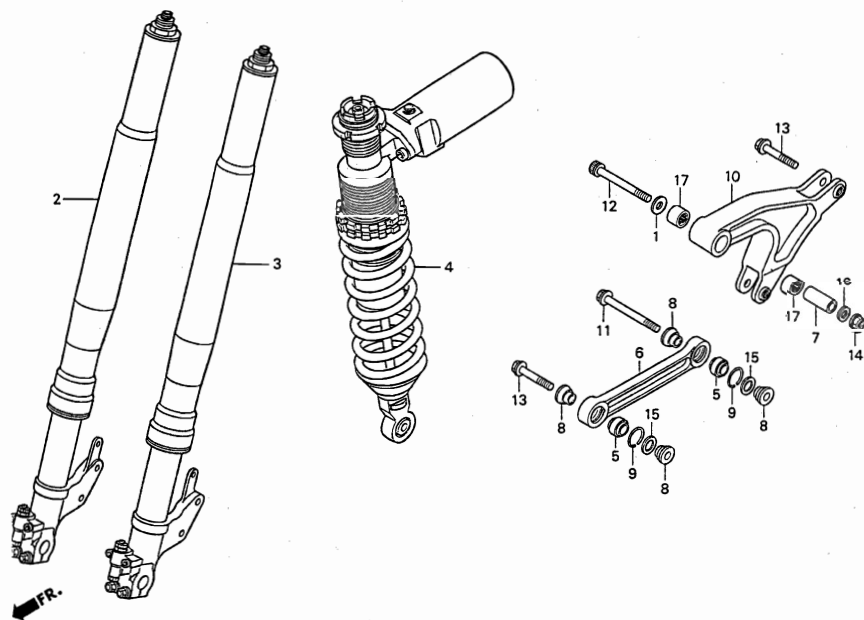

Ref. No.	Part No.	Description	Reqd. No.		Remarks	Ref. No.	Part No.	Description	Reqd. No.		Remarks
			'97	'98					'97	'98	
1	24707-MR7-000	WASHER, change pivot	1	1							
2		FORK ASSY. R. front	1	1	SHOWA No sale by HRC						
3		FORK ASSY. L. front	1	1	SHOWA No sale by HRC						
4		CUSHION ASSY. rear	1	1	SHOWA No sale by HRC						
- 5	52422-NF5-952	BEARING, spherical	2	2							
- 6	52461-NX6-000	ROD, cushion	1	1							
7	52464-KAK-900	COLLAR, cushion lower	1	1							
- 8	52468-NF5-000	COLLAR, tension rod	4	4							
- 9	52469-NC8-000	SNAP RING, 22mm	2	2							
- 10	52471-NX6-020	ARM, cushion	1	1							
- 11	90102-NF5-000	BOLT, flange 10x50	1	1							
12	90110-MR8-000	BOLT, socket 10x52	1	1							
13	90153-KS7-830	BOLT, flange 10x38	2	2							
14	90304-GA6-003	NUT, axle	1	1							
- 15	90501-ND5-750	WASHER, 12x16x0.1	N	N							
16	90528-230-000	WASHER, 10.2x20	1	1							
- 17	91106-NX5-003	BEARING, needle 15mm	2	2							

Block No.

F-14

Ignition coil
Wire harness

'97 NSR500V
'98 NSR500V

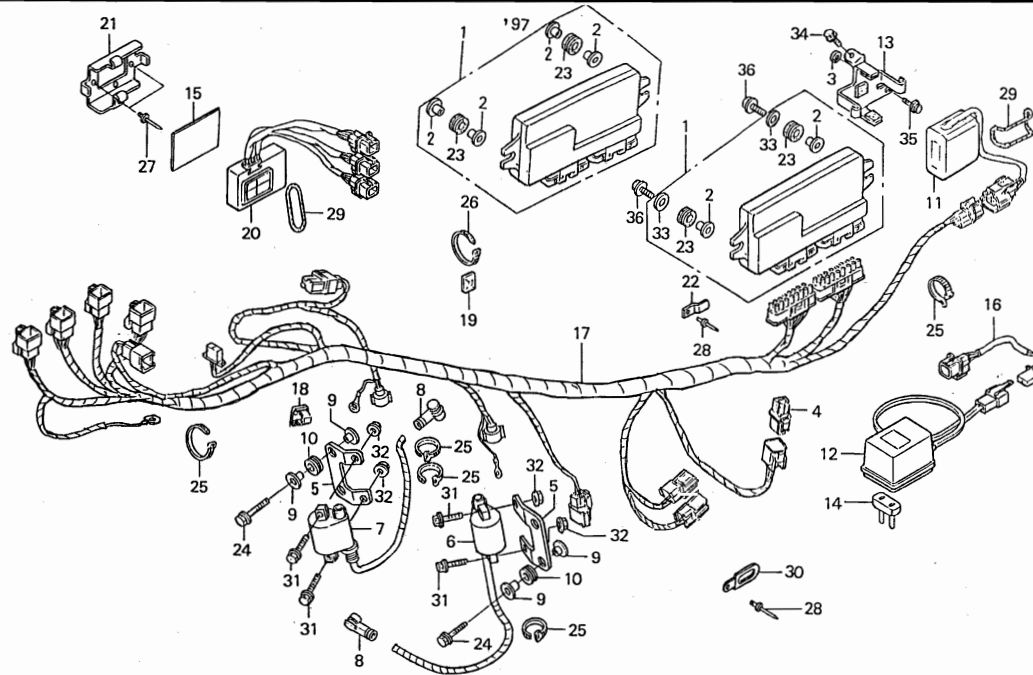

Ref. No.	Part No.	Description	Reqd. No.		Remarks	Ref. No.	Part No.	Description	Reqd. No.		Remarks
			'97	'98					'97	'98	
- 1	30400-NX6-003	UNIT ASSY. engine control	1	—		- 20	38500-NX6-601	UNIT ASSY. detonation counter	(1)	1	
-	30400-NX6-700	UNIT ASSY. engine control	—	1		- 21	38501-NX6-600	HOLDER, detonation counter	1	—	
- 2	30401-NX6-300	COLLAR, ECU. mount	4	—		- 22	38501-NX6-700	HOLDER, detonation counter	(1)	1	
	50324-425-010	COLLAR, 6.3×13	(2)	2		- 23	50193-NX6-000	STAY, coupler	9	13	
3	30407-KE7-000	COLLAR, ignition coil	1	1		23	80106-382-770	RUBBER, rear fender mount	2	2	
- 4	30411-NX6-600	COUPLER, mode 1	(1)	—	For leaded	24	90197-MN5-000	BOLT, flange 5×20	4	4	
-	30413-NX6-600	COUPLER, mode 3	1	—	For unleaded	- 25	90651-NC8-000	TIE-WRAP, 3.6×281	5	5	
- 5	30507-NX6-000	STAY, ignition coil	2	2		- 26	90652-ND5-000	TIE-WRAP, 2.4×92	1	1	
- 6	30510-NX6-003	COIL COMP. ignition #1	1	1		- 27	90851-NL0-700	RIVET, 3.2×9.5	(3)	3	
- 7	30520-NX6-003	COIL COMP. ignition #2	1	1		- 28	91080-NC8-300	RIVET, 3.2×6.4	9	13	
- 8	30700-NX5-003	CAP ASSY. noise suppressor	2	2		29	91301-428-003	O-RING, 35.5×3	1	2	
- 9	30805-NX6-000	COLLAR, ignition mount	8	8		30	91406-657-671	CLIP, wire harness	—	1	
- 10	30806-NX6-000	RUBBER, ignition mount	4	4		31	92101-05018-0A	BOLT, 5×18	4	4	
- 11	31500-NX6-000	BATTERY ASSY.	1	1		32	94001-05000-0S	NUT, hex 5mm	4	4	
- 12	31510-NF5-951	CHARGER ASSY. NI-CD battery	(1)	(1)	AC100V	33	94103-06000	WASHER, plain 6mm	(2)	2	
-	31510-NF5-961	CHARGER ASSY. NI-CD battery	(1)	(1)	AC220V	34	96001-06010-00	BOLT, flange SH 6×10	1	1	
- 13	31510-NX6-000	HOLDER, battery	1	1		35	96001-06016-00	BOLT, flange SH 6×16	1	1	
- 14	31511-NF5-960	POWER PLUG, C-type	(1)	(1)		36	96001-06025-00	BOLT, flange SH 6×25	2	2	
- 15	31512-NL5-000	SPONGE, mount	(1)	1							
- 16	31513-NX6-000	SUB HARNESS, charger	(1)	(1)							
- 17	32100-NX6-000	HARNESS, wire	1	—							
-	32100-NX6-700	HARNESS, wire	—	1							
- 18	32112-NF5-950	CLAMPER, harness	2	2							
- 19	32114-NF4-780	BASE, tie-wrap	1	1							

Block No.

F-15

Frame body

'97 NSR500V

'98 NSR500V

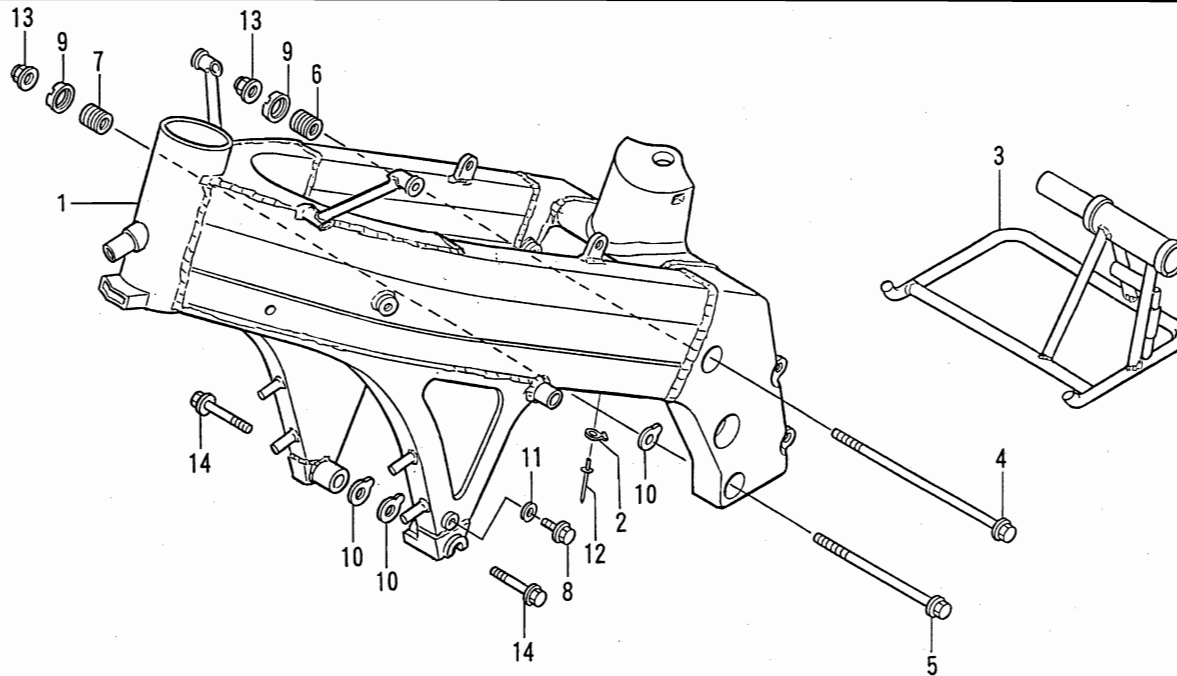

Ref. No.	Part No.	Description	Reqd. No.		Remarks	Ref. No.	Part No.	Description	Reqd. No.		Remarks
			'97	'98					'97	'98	
- 1	50100-NX6-000	FRAME BODY COMP.	1							
-	50100-NX6-700	FRAME BODY COMP.	(1) 1							
- 2	52161-NF5-710	HOSE BASE, saddle	1	1						
- 3	85000-NX6-000	STAND ASSY. main	1	1					No sale by HRC	
- 4	90101-NX6-000	BOLT, flange 10×294	1	1						
- 5	90102-NX6-000	BOLT, flange 10×271	1	1						
- 6	90124-NX4-000	BOLT, engine mount adjust 18×34.5	..	1	1						
- 7	90124-NX6-000	BOLT, engine mount adjust 18×23.5	..	1	1						
- 8	90134-ND5-000	BOLT, flange 6×10	1	1						
- 9	90301-NX4-000	NUT, lock M18×1.5	2	2						
- 10	90510-NX4-000	SHIM, engine mount 0.2	N	N						
-	90511-NX4-000	SHIM, engine mount 0.6	N	N						
-	90512-NX4-000	SHIM, engine mount 1.0	N	N						
-	90513-NX4-000	SHIM, engine mount 1.5	N	N						
11	90543-273-000	PACKING, front fork drain cock	1	1						
- 12	91080-NF5-710	RIVET, 4.0×8.6	1	1						
13	94050-10000	NUT, flange 10mm	2	2						
14	96500-10028-00	BOLT, flange DR 10×28	2	2						

Block No.

F-16

Radiator

'97 NSR500V

'98 NSR500V

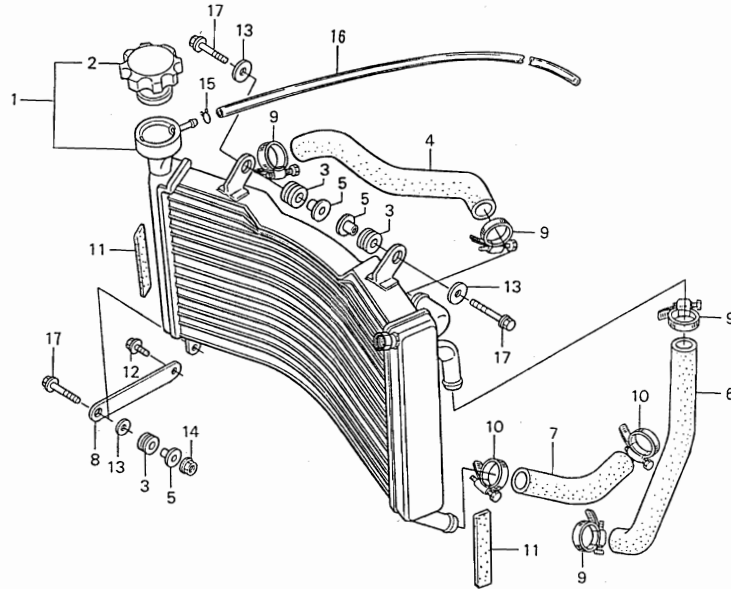

Ref. No.	Part No.	Description	Reqd. No.		Remarks	Ref. No.	Part No.	Description	Reqd. No.		Remarks
			'97	'98					'97	'98	
- 1	19010-NX6-000	RADIATOR COMP.	1	1							
- 2	19037-NX5-003	FILLER CAP COMP.	1	1							
3	19051-KA3-830	RUBBER, radiator mount	3	3							
- 4	19051-NX6-000	HOSE, A. water	1	1							
5	19052-KA3-830	COLLAR, radiator mount	3	3							
- 6	19052-NX6-000	HOSE, B. water	1	1							
- 7	19053-NX6-000	HOSE, C. water	1	1							
- 8	19110-NX6-010	STAY, radiator	1	1							
- 9	19515-NX6-700	BAND, hose 19-28	4	4							
- 10	19516-NX6-700	BAND, hose 26-38	2	2							
11	50383-HC4-750	RUBBER, battery rear	2	2							
- 12	90134-ND5-000	BOLT, flange 6x10	1	1							
13	90403-KA3-830	WASHER, radiator mount	3	3							
14	94050-06000	NUT, flange 6mm	1	1							
15	95002-45000	CLIP, C8 tube	1	1							
- 16	95003-10022-31	V-TUBE, 5x8x220	1	1	Available length 1M only						
17	96001-06025-00	BOLT, flange SH 6x25	3	3							

Block No.

F-17

Cowl

'97 NSR500V
'98 NSR500V

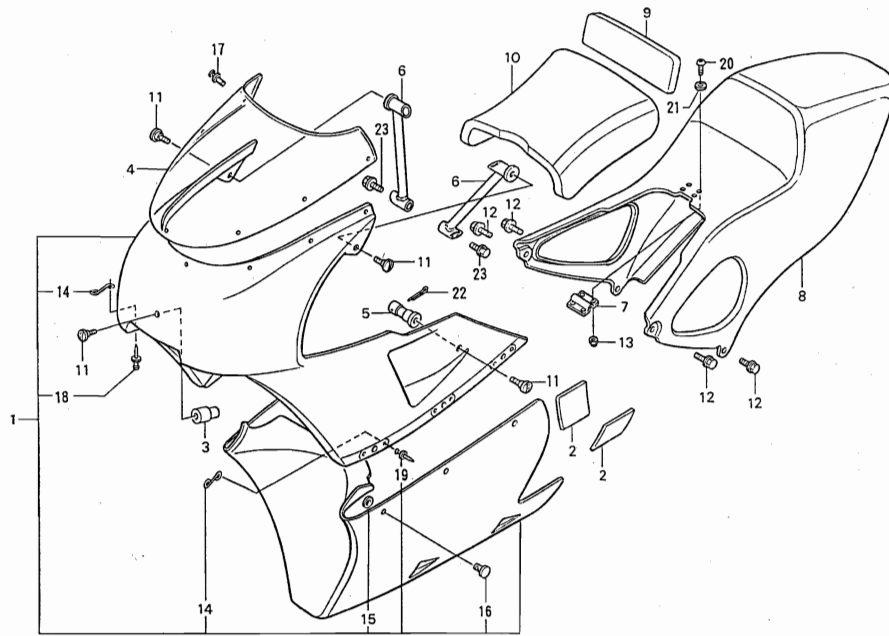

Ref. No.	Part No.	Description	Reqd. No.		Remarks	Ref. No.	Part No.	Description	Reqd. No.		Remarks
			'97	'98					'97	'98	
- 1	64100-NX6-000	COWL COMP. front	1	1		23	96001-06012-00	BOLT, flange SH 6×12	2	2	
- 2	64109-NF5-750	SHEET, heat proof	2	2							
- 3	64109-NX6-000	BOSS, center cowl	1	1							
- 4	64200-NX6-000	SCREEN, front	1	1							
- 5	64210-NX6-000	STAY, cowl side	2	2							
- 6	64240-NX6-000	STAY, cowl up	2	2							
- 7	77191-NX6-000	STAY, fuel tank mount	1	1							
- 8	77210-NX6-000	COWL COMP. seat	1	—							
-	77210-NX6-700	COWL COMP. seat	(1)	1							
- 9	77221-NF5-760	RUBBER, seat back	1	1							
- 10	77230-NL5-700	RUBBER, seat (20)	1	1							
- 11	90106-NF4-770	BOLT, cowl set 6×13	5	5							
12	90106-SM5-A00	BOLT, flange 6×16	4	4							
- 13	90310-NF4-000	NUT, self lock 3mm	4	4							
- 14	90653-NC8-000	SPRING, fastener 35	8	8							
- 15	90654-NC8-000	GROMMET, fastener	6	6							
- 16	90655-NC8-000	STUD, fastener 35	6	6							
- 17	90656-NX4-000	RIVET, 4×7	7	7							
- 18	90656-NX6-000	RIVET, 3.2×6.4 flat	4	4							
- 19	91080-NC8-300	RIVET, 3.2×6.4	12	12							
20	93500-03014-0A	SCREW, pan 3×14	4	4							
21	94101-03000	WASHER, plain 3mm	4	4							
22	94201-25300	PIN, split 2.5×30	2	2							

' 97 . ' 98 - NSR500V PART NO. INDEX

Part No.	Block	Part No.	Block	Part No.	Block	Part No.	Block	Part No.	Block
04601-ND5-760	F-6	14113-NX6-701	E-6	16950-NX6-000	F-8	19051-KA3-830	F-16	23415-NX6-000	E-8
04602-ND5-760	F-6	14121-NX6-000	E-6	17200-NX6-000	F-9	19051-NX6-000	F-16	23421-NX6-000	E-8
04603-NF4-770	F-6	14122-NX6-000	E-6	17210-NX6-000	F-9	19052-KA3-830	F-10	23422-NX6-000	E-8
11000-NX6-305	E-6	14131-NX6-000	E-6	17220-NX6-000	F-9		F-16	23423-NX6-000	E-8
11000-NX6-306	E-6	14210-NX6-305	E-1	17220-NX6-700	F-9	19052-NX6-000	F-16	23424-NX6-000	E-8
11106-CM2-300	E-6	14248-NX6-000	E-3	17221-NX6-000	F-9	19053-NX6-000	F-16	23425-NX6-000	E-8
11130-NX6-000	E-9	14249-NX6-000	E-3	17359-419-670	F-9	19110-NX6-010	F-16	23431-NX6-000	E-8
11331-NX6-000	E-2	14311-NX6-000	E-1	17370-419-700	F-6	19210-NX6-000	E-5	23432-NX6-000	E-8
11395-NX6-000	E-2	14312-NX6-000	E-1	17510-NX6-010	F-8	19215-NX6-000	E-5	23433-NX6-000	E-8
12101-NX6-000	E-1	14313-NX6-000	E-1	17510-NX6-700	F-8	19219-NX6-000	E-5	23434-NX6-000	E-8
12101-NX6-700	E-1	14315-NX6-000	E-1	17511-NX5-770	F-8	19220-NX6-000	E-5	23435-NX6-000	E-8
12103-KZ3-700	E-1	14337-NX5-003	E-3	17515-NX5-770	F-8	19229-NX6-000	E-5	23441-NX6-010	E-8
12107-MT7-000	F-10	14338-NX5-003	E-3	17516-NF4-610	F-8	19233-NX6-000	E-5	23442-NX6-010	E-8
12191-NX6-000	E-1	14411-NX6-000	E-1	17517-NF4-610	F-8	19515-NX6-700	F-16	23443-NX6-010	E-8
12211-NX6-000	E-1	14421-NX6-000	E-1	17521-NF5-950	F-8	19516-NX6-700	F-16	23444-NX6-010	E-8
12211-NX6-600	E-1	15115-NX6-000	E-9	17522-NF5-690	F-8	19601-NX6-000	F-8	23445-NX6-010	E-8
12211-NX6-700	E-1	15611-NF4-900	E-2	17525-NX6-000	F-8	22100-NX6-000	E-2	23446-NX6-010	E-8
12212-NX6-003	E-1	16011-NX6-000	E-10	17527-NC8-000	F-8	22100-NX6-305	E-2	23447-NX6-010	E-8
12213-NX6-003	E-1	16013-NX6-000	E-10	17528-NF4-000	F-8	22103-HA0-300	E-2	23448-NX6-010	E-8
13000-NX6-000	E-7	16014-NX6-010	E-10	17701-NX6-000	F-8	22106-NX6-000	E-2	23451-NX6-000	E-8
13000-NX6-700	E-7	16015-NX6-000	E-10	17724-102-700	F-8	22108-NX6-000	E-2	23451-NX6-700	E-8
13100-NX6-303	E-7	16016-NX6-000	E-10	17810-NX6-000	F-1	22108-NX6-700	E-2	23452-NX6-000	E-8
13100-NX6-700	E-7	16017-NX6-000	E-10	17910-NX6-000	F-2	22111-NX6-000	E-2	23452-NX6-700	E-8
13111-NX6-000	E-7	16041-NX6-000	E-10	17920-NX6-000	F-2	22112-NX6-000	E-2	23453-NX6-000	E-8
13111-NX6-700	E-7	16060-NX6-000	E-10	17955-NF5-750	F-1	22113-NX6-000	E-2	23453-NX6-700	E-8
13112-NX6-010	E-7	16070-NX6-010	E-10	18100-NX6-000	E-3	22120-NX6-000	E-2	23454-NX6-000	E-8
13115-NX6-303	E-7	16100-NX6-020	E-10	18152-NX6-000	E-3	22201-NX6-000	E-2	23454-NX6-700	E-8
13121-NX6-003	E-7	16100-NX6-700	E-10	18155-NX6-000	E-3	22210-NX6-000	E-2	23455-NX6-000	E-8
13121-NX6-700	E-7	16111-NX6-000	E-10	18310-NX6-000	F-10	22321-NX6-000	E-2	23455-NX6-700	E-8
13201-NX6-300	E-7	16112-NX6-000	E-10	18310-NX6-700	F-10	22351-NX6-000	E-2	23456-NX6-000	E-8
13202-NX6-300	E-7	16113-NX6-000	E-10	18320-NX6-000	F-10	22401-NX6-000	E-2	23456-NX6-700	E-8
13203-NX6-300	E-7	16178-NX6-010	E-10	18320-NX6-700	F-10	22810-NX6-000	E-6	23473-NX6-000	E-8
13331-360-000	E-4	16196-NX6-010	E-10	18330-NX6-000	F-10	22815-NX6-000	E-6	23473-NX6-700	E-8
13415-NX6-000	E-7	16199-GN2-671	E-10	18332-KS6-000	F-10	22841-NX6-000	E-2	23474-NX6-000	E-8
13420-NX6-000	E-5	16201-NX6-010	E-10	18333-ND4-760	F-10	22850-NX6-000	E-2	23474-NX6-700	E-8
13426-NX6-000	E-5	16202-NX6-010	E-10	18351-NX6-000	E-1	22870-NX6-000	F-2	23475-NX6-000	E-8
13615-NX6-000	E-7	16203-NX6-010	E-10	18351-NX6-700	E-1	23211-NX6-000	E-8	23475-NX6-700	E-8
13617-NX6-000	E-7	16204-NX6-010	E-10	18352-NX6-000	E-1	23212-NX6-000	E-8	23481-NX6-000	E-8
14100-NX6-000	E-6	16205-NX6-010	E-10	18370-NX6-000	F-10	23221-NX6-000	E-8	23482-MV9-670	E-8
14100-NX6-600	E-6	16206-NX6-010	E-10	18371-NX6-000	F-10	23225-NX6-000	E-8	23483-NX6-000	E-8
14100-NX6-701	E-6	16207-NX6-010	E-10	18373-NX6-000	F-10	23411-NX6-000	E-8	23484-NX6-000	E-8
14110-NX6-000	E-6	16208-NX6-000	E-10	18374-NX6-000	F-10	23412-NX6-000	E-8	23491-NX6-000	E-8
14110-NX6-600	E-6	16209-NX6-000	E-10	18380-NX6-000	F-10	23413-NX6-000	E-8	23491-NX6-700	E-8
14111-NX6-000	E-6	16210-NX6-000	E-6	19010-NX6-000	F-16	23414-NX6-000	E-8	23492-NX6-000	E-8
14112-NX6-000	E-6	16219-NX6-000	E-6	19037-NX5-003	F-16			23492-NX6-700	E-8
14112-NX6-600	E-6	16220-NX6-000	E-6	19051-KA3-830	F-10			23493-NX6-000	E-8

' 97 ' 98 - NSR500V PART NO. INDEX

Part No.	Block	Part No.	Block	Part No.	Block	Part No.	Block	Part No.	Block
23493-NX6-700	E-8	24710-NX6-000	F-11	40530-NX6-013	F-12	46500-NF4-780	F-11	53165-KT8-710	F-2
23494-NX6-000	E-8	24710-NX6-700	F-11	40531-NX6-013	F-12	46501-ND4-750	F-11	53166-KT8-710	F-2
23494-NX6-700	E-8	24711-NC8-000	F-11	41235-NX6-000	F-7	50100-NX6-000	F-15	53167-NX6-000	F-2
23495-MB0-000	E-8	24712-NC8-000	F-11	41236-NX6-000	F-7	50100-NX6-700	F-15	53168-KV3-701	F-2
23504-NX6-000	E-8	30400-NX6-003	F-14	41237-NX6-000	F-7	50193-NX6-000	F-14	53172-430-003	F-2
23505-NX6-000	E-8	30400-NX6-700	F-14	41238-NX6-000	F-7	50222-HB5-000	F-10	53173-376-000	F-2
23512-NX6-000	E-8	30401-NX6-300	F-14	41239-NX6-000	F-7	50324-425-010	F-14	53178-399-700	F-2
23514-NX6-000	E-8	30407-KE7-000	F-14	41240-NX6-000	F-7	50383-HC4-750	F-8	53192-KA4-710	F-2
23514-NX6-700	E-8	30411-NX6-600	F-14	42301-NX6-000	F-7		F-16	53200-NX6-000	F-4
23802-NX6-000	E-8	30413-NX6-600	F-14	42510-NX6-700	F-7	50610-NL5-760	F-11	53200-NX6-305	F-4
23803-NX6-000	E-8	30507-NX6-000	F-14	42615-NX6-000	F-7	50612-NL5-760	F-11	53200-NX6-306	F-4
23804-NX6-000	E-8	30510-NX6-003	F-14	42617-NX6-000	F-7	50630-NX6-000	F-11	53214-MR7-003	F-4
24211-NX6-000	E-9	30520-NX6-003	F-14	42720-NC8-000	F-5	50640-NX6-000	F-11	53230-NX6-000	F-4
24211-NX6-700	E-9	30700-NX5-003	F-14		F-7	50641-NF5-950	F-11	53231-NX6-000	F-4
24221-NX6-000	E-9	30805-NX6-000	F-14	42753-ML7-004	F-5	50642-NF4-770	F-11	53232-NX6-000	F-4
24221-NX6-700	E-9	30806-NX6-000	F-14		F-7	50643-NL5-760	F-11	53700-NF5-762	F-4
24231-NX6-000	E-9	31100-NX6-003	E-4	43100-NL5-701	F-6	50643-NX4-770	F-11	53705-NF5-760	F-4
24231-NX6-700	E-9	31100-NX6-700	E-4	43105-NL5-700	F-6	50643-NX6-700	F-11	53710-NF5-611	F-4
24265-NX6-000	E-9	31420-NX6-000	F-1	43110-NX6-000	F-7	50810-NX6-000	F-1	61100-NX6-000	F-4
24265-NX6-700	E-9	31424-NX6-000	F-1	43111-NX6-000	F-12	50811-NF4-770	F-1	64100-NX6-000	F-17
24310-NX6-000	E-9	31426-NX6-000	F-1	43112-NX6-000	F-12	50815-NX4-000	F-1	64109-NF5-750	F-17
24312-NX6-000	E-9	31500-NX6-000	F-14	43121-NL5-700	F-7	50816-NX4-000	F-1	64109-NX6-000	F-17
24315-HA0-000	E-9	31510-NF5-951	F-14	43150-NX6-000	F-12	52101-NX6-000	F-12	64200-NX6-000	F-17
24321-KW6-902	E-9	31510-NF5-961	F-14	43160-NX6-000	F-12	52102-NX6-000	F-12	64210-NX6-000	F-17
24321-NX6-700	E-9	31510-NX6-000	F-14	43215-NL5-701	F-6	52106-NX4-000	F-12	64240-NX6-000	F-17
24322-MM4-000	E-9	31511-NF5-960	F-14	43310-NX6-000	F-6	52109-NX4-000	F-12	77191-NX6-000	F-17
24322-NX6-700	E-9	31512-NL5-000	F-14	43352-568-003	F-6	52110-NX6-000	F-12	77210-NX6-000	F-17
24324-NX6-000	E-9	31513-NX6-000	F-14	43353-461-771	F-6	52158-KA3-831	F-12	77210-NX6-700	F-17
24325-NX6-000	E-9	31600-NX6-003	F-1	43500-NX6-000	F-6	52161-NF5-710	F-6	77221-NF5-760	F-17
24326-KBH-901	E-9	31940-NX6-000	E-1	43503-NF4-000	F-6		F-15	77230-NL5-700	F-17
24328-NX6-000	E-9	32100-NX6-000	F-14	43504-NF4-770	F-6	52170-NX5-000	F-12	80106-382-770	F-14
24329-KA3-740	E-9	32100-NX6-700	F-14	43541-ND5-750	F-6	52175-NX6-000	F-12	80108-028-000	F-10
24329-NX6-000	E-9	32112-NF5-950	F-14	44300-NF5-610	F-5	52175-NX6-700	F-12	85000-NX6-000	F-15
24329-NX6-700	E-9	32114-NF4-780	F-14	44620-ND5-750	F-5	52422-NF5-952	F-13	87208-NC2-000	F-8
24430-NX6-000	E-9	35132-KR5-013	F-2	44621-NF5-750	F-5	52461-NX6-000	F-13	87521-ML0-731	F-12
24430-NX6-700	E-9	35300-NX6-003	F-2	45103-MR7-006	F-6	52464-KAK-900	F-13	87560-357-671	F-8
24435-NX6-010	E-9	35750-NX6-700	E-6	45125-NX6-000	F-3	52468-NF5-000	F-13	90001-NX6-000	E-6
24610-NX6-010	E-9	36172-KV3-701	F-1	45126-NX6-000	F-3	52469-NC8-000	F-13	90002-GHB-690	F-1
24615-NX6-000	E-6	36190-NX6-003	F-1	45127-KZ4-003	F-3	52471-NX6-020	F-13	90002-NX6-000	E-6
24616-NX6-000	E-9	37250-NX6-003	F-1		F-6	53105-NF4-770	F-2	90003-MC7-000	F-5
24618-NX6-000	E-9	37460-NX4-701	F-1	45127-NX6-000	F-3	53110-NL5-700	F-2	90003-NX6-000	E-7
24651-NX6-000	E-9	37870-NF4-611	F-1	45128-NX6-000	F-3	53111-HE0-000	F-9	90004-GHB-630	E-6
24700-NF4-780	F-11	38500-NX6-601	F-14	45129-NL5-700	F-3	53111-NX6-000	F-2	90004-GHB-650	E-1
24700-NX6-700	F-11	38501-NX6-600	F-14	45209-KV3-951	F-6	53120-NL5-700	F-2		E-2
24706-NX6-000	F-11	38501-NX6-700	F-14	45500-NL5-701	F-3	53141-MT7-000	F-2		E-4
24707-MR7-000	F-13	38510-NX6-600	E-1	45530-NF4-650	F-6	53160-NL5-701	F-3		E-6
		38511-NX6-000	E-1						

' 97 . ' 98 - NSR500V PART NO. INDEX

Part No.	Block	Part No.	Block	Part No.	Block	Part No.	Block	Part No.	Block
90004-GHB-660	E-1	90153-KS7-830	F-13	90451-KG4-000	E-2	90653-MR7-000	F-7	91080-NC8-300	F-14
	E-9	90178-NC8-000	F-11	90451-MR7-000	E-8	90653-NC8-000	F-17		F-17
90004-GHB-670	E-5	90197-MN5-000	F-14	90452-MR7-000	E-8	90654-NC8-000	F-17	91080-NF5-710	F-6
90004-GHB-680	E-2	90201-KV3-700	F-11	90453-752-830	F-11	90655-NC8-000	F-17		F-15
90004-GHB-720	E-3	90201-NF5-000	E-3	90456-MA6-000	E-8	90655-NX6-000	F-9	91082-NF5-000	F-9
	E-5	90204-NX6-000	E-1	90461-759-000	E-8	90656-NX4-000	F-17	91101-NX6-003	E-7
90004-GHB-730	E-5	90205-NX6-000	E-1	90462-MR7-000	E-8	90656-NX6-000	F-17	91102-230-000	E-7
90004-NX6-000	E-5	90208-NX6-000	E-2	90463-MR7-000	E-8	90657-NX6-000	F-9	91102-NX6-003	E-7
90005-NX6-000	E-9	90301-473-003	E-3	90464-MR7-000	E-8	90751-NL5-700	F-7	91103-NX6-003	E-7
90006-NX6-000	E-1	90301-NX4-000	F-15	90465-MR7-000	E-8	90754-NX5-770	F-9	91104-NX6-003	E-7
90007-NX6-000	E-8	90302-MR7-000	F-4	90471-NX6-000	E-6	90755-NX5-770	F-9	91105-NX6-003	E-7
90008-NX6-000	E-6	90302-NF5-760	F-4		E-9	90756-NX5-770	F-9	91106-NX5-003	F-13
90009-NX6-000	E-6	90302-NX5-000	F-2	90485-GB4-790	F-4	90851-NL0-700	F-14	91106-NX6-003	E-7
90013-NX6-000	E-9		F-7	90497-NX6-000	E-2	91001-CBT-003	E-6	91110-NX6-003	E-7
90013-NX6-700	E-9	90304-GA6-003	F-13	90501-399-880	F-12	91001-KA4-003	E-5	91110-NX6-701	E-7
90014-KV3-680	E-6	90305-KZ4-891	F-12	90501-MB7-610	E-5	91001-KV3-831	E-7	91112-NX6-003	E-7
90021-NX6-000	E-6	90305-ML7-000	F-5	90501-MR7-003	F-7	91001-NX6-700	E-7	91112-NX6-701	E-7
90022-MN5-000	E-2	90309-428-731	F-7	90501-ND5-750	F-13	91002-HA2-008	E-6	91113-NX6-003	E-7
90037-NX5-000	E-1	90309-NL5-700	F-7	90510-NX4-000	F-15	91002-KV3-831	E-7	91113-NX6-701	E-7
	E-5	90310-NF4-000	F-17	90511-NX4-000	F-15	91004-NX6-003	E-6	91114-NX6-003	E-7
90080-NX6-000	E-6	90315-MR7-000	F-7	90512-NX4-000	F-15	91004-NX6-701	E-6	91114-NX6-701	E-7
90082-NX5-000	E-6	90321-KF0-000	F-2	90513-NX4-000	F-15	91005-NX6-003	E-7	91201-965-000	E-5
90101-692-000	F-12	90355-NX4-000	F-12	90528-230-000	F-13	91005-NX6-701	E-7	91201-NX6-300	E-7
90101-NX6-000	F-15	90401-KZ4-890	F-12	90543-273-000	E-1	91006-NX6-300	E-7	91201-VA4-801	E-6
90102-NF5-000	F-13	90403-KA3-830	F-1		E-5	91007-NX6-003	E-9	91202-MR7-003	F-12
90102-NX6-000	F-15		F-16		E-6	91008-NX6-003	E-6	91204-GK8-003	E-6
90106-NF4-770	F-17	90403-NX6-000	E-7		F-15	91011-NX6-003	E-9	91204-NX6-000	E-6
90106-SM5-A00	F-17	90404-KV3-830	E-8	90558-MB0-000	E-6	91012-NX6-003	E-6	91205-KF0-003	E-1
90108-GK1-000	F-3	90404-NX6-000	E-1	90601-107-000	E-8	91012-NX6-303	E-6	91205-NX6-000	E-7
	F-4	90405-NX6-000	E-1	90601-ZE1-000	F-3	91016-MR7-003	F-4	91205-PH8-005	E-1
90108-NF4-000	F-12	90406-NX6-000	E-1		F-6	91021-148-006	E-6	91206-NX6-000	E-7
90110-MR8-000	F-13	90407-NX6-000	E-1	90603-MN4-000	E-8	91021-415-005	E-2	91210-723-751	E-6
90111-NX4-000	F-3	90408-NX6-000	E-1	90613-PP4-300	F-11	91022-NX6-003	E-9	91211-KA3-761	E-5
90113-MR7-000	F-7	90409-NX6-000	E-1	90651-ML0-731	F-7	91023-NX6-003	E-6	91214-MR7-003	F-12
90114-310-000	F-2	90411-NX6-000	E-2	90651-NC8-000	F-2		E-9	91222-NX6-003	E-2
90114-MW4-850	F-7	90412-NX6-000	E-2		F-3	91024-GJ5-003	E-1	91253-KM1-003	E-2
90120-NL5-700	F-6	90413-NX6-000	E-2		F-6		E-3	91301-147-023	E-1
90120-NX5-000	F-7	90414-NX6-000	E-2		F-8	91024-NX6-003	E-6	91301-428-003	F-14
90122-NX6-000	F-7	90415-NX6-000	E-2		F-12	91026-MN0-003	E-8	91301-NX6-003	E-7
90124-NX4-000	F-15	90432-MB0-010	E-2		F-14	91034-NX6-003	E-1		E-8
90124-NX6-000	F-15	90441-422-000	E-1	90652-GHB-690	E-6		E-3	91302-NX6-003	E-1
90134-ND5-000	F-15	90441-NX6-700	E-4	90652-ND5-000	F-2	91058-NX6-700	F-11	91303-NX6-000	E-6
	F-16	90443-107-000	E-1		F-3	91060-NL0-003	F-4	91304-MJ0-003	E-2
90134-NX5-000	E-6	90443-MB0-000	E-6		F-8	91061-ML0-731	F-7	91305-KK4-003	E-6
90145-NX5-004	F-3	90445-MW4-000	E-6		F-14	91062-NX5-003	F-7	91307-PK2-005	F-1
90152-NX6-000	F-12	90447-KE1-000	E-5	90652-NX5-000	F-7	91071-MR7-003	F-12	91312-NC8-000	E-2
						91072-MR7-003	F-12		

' 97 ' 98 - NSR500V PART NO. INDEX

Part No.	Block	Part No.	Block	Part No.	Block	Part No.	Block	Part No.	Block
91361-MT3-003	E-2	94301-12160	E-6	96001-06028-00	F-4				
91361-NX6-700	E-2	94303-04065	E-1	96001-06035-00	F-4				
91406-657-671	F-14		E-9	96150-60040-10	F-5				
92101-05018-0A	F-14	94303-08140	E-6	96211-07000	E-2				
92101-08032-0A	F-4	94520-16000	E-9	96400-08045-00	F-4				
92301-05014-0A	E-3	94520-19000	E-1	96500-08025-00	F-12				
92301-05016-0A	E-3		E-3	96500-08035-00	F-2				
92900-06028-0B	E-6	94520-37000	F-12		F-4				
92900-06035-0B	E-6	94520-42000	F-5	96500-10028-00	F-15				
93500-03008-0A	F-10	94560-68200	E-7	96700-08028-10	F-4				
	F-12	94601-17000	F-4	99103-427-0380	E-10				
93500-03014-0A	F-17	95002-02070	E-6	99103-427-0400	E-10				
93500-04012-1A	E-10	95002-02130	F-6	99103-427-0420	E-10				
93500-05016-0A	F-2	95002-40850-08	F-3	99103-427-0450	E-10				
93500-05020-0G	F-2	95002-45000	F-8	99103-427-0480	E-10				
93600-06012-0A	E-6		F-16	99103-437-0350	E-10				
	E-9	95002-80000	F-8	99103-437-0380	E-10				
93892-04014-10	E-10		F-9	99103-437-0400	E-10				
94001-05000-0S	E-3	95003-10022-31	F-16	99103-437-0420	E-10				
	F-14	95003-10045-31	F-8	99103-437-0450	E-10				
94001-06200-0S	F-11	95003-10030-31	E-6	99113-GHB-1600	E-10				
94001-12200-0S	E-4	95003-11015-60	F-3	99113-GHB-1620	E-10				
94050-06000	E-6	95003-19018-31	F-9	99113-GHB-1650	E-10				
	E-9	95003-19025-31	F-8	99113-GHB-1680	E-10				
	F-1	95003-19052-31	F-8	99113-GHB-1700	E-10				
	F-10	95701-08040-00	F-6	99113-GHB-1720	E-10				
	F-11	95701-08055-00	E-6	99113-GHB-1750	E-10				
	F-16	95801-08045-00	F-11	99113-GHB-1780	E-10				
94050-08000	F-4		F-12	99113-GHB-1800	E-10				
	F-12	96001-06010-00	F-14	99113-GHB-1820	E-10				
94050-10000	E-1	96001-06012-00	E-6	99113-GHB-1850	E-10				
	F-15		F-1	99113-GHB-1880	E-10				
94101-03000	F-12		F-10	99113-GHB-1900	E-10				
	F-17		F-11	99113-GHB-1920	E-10				
94101-06000	F-11		F-17	99113-GHB-1950	E-10				
94101-08000	F-11	96001-06016-00	F-14	99113-GHB-1980	E-10				
94102-08000	F-4	96001-06018-00	F-6	99113-GHB-2000	E-10				
	F-12		F-11	99113-GHB-2050	E-10				
94103-06000	F-14	96001-06020-00	F-11	99113-GHB-2100	E-10				
94201-25300	F-17	96001-06022-00	F-2	99113-GHB-2150	E-10				
94251-05000	F-6		F-10	99113-GHB-2200	E-10				
94301-06100	E-1	96001-06025-00	F-1	99113-GHB-2250	E-10				
	E-9		F-10	99113-GHB-2300	E-10				
94301-08100	E-2		F-11						
	E-3		F-14						
	E-5		F-16						
	E-9								

HONDA RACING CORPORATION

Head Office/3-15-1 Senzui, Asaka-shi, Saitama-pref, 351, Japan

TEL.048-461-9511 TELFAX.048-469-0068

European Office/Wijngaardveld 1, B 9300. Aalst. Belgium.

TEL.053-78-6131 TELFAX.053-77-5767

