

The Battle Shifter by Battle Factory is a lightweight, compact semi-automatic upshifting system that provides quick, smooth shifts every time. Unlike other popular shifters, the Battle Shifter works by automatically adjusting the duration of the ignition cut to match RPM's – longer cuts at low RPM's and shorter ones at high RPM's. Whereas other shifter setups simply act as a switch that cut power completely, the Battle Shifter reduces current to the ignition coil to stop spark. This ensures that juice keeps flowing to your gauges, eliminating annoying readout flashes and reducing overall system shock to provide the smoothest shift possible.

The Battle Shifter automatically cuts out under 3,000 RPM's to prevent engine stall during slow speeds and idle and comes fully setup for your bike from the factory eliminating the need to adjust the length of the ignition cut.

Your Battle Shifter comes with:

- ? . Battle Shifter control unit..... x 1
- ? Pull switch set..... x 1
- ? Zip straps 250 mm (for attaching the unit)..... x 2
- ? Rubber sponge..... x 1
- ? Connector x 1
- ? Large sticker x 1
- ? Special adjustment screwdriver..... x 1

IMPORTANT:

- ~~⚡~~ To ensure the long life of your unit, please read all instructions carefully.
 - ~~⚡~~ Check that the adjustment window is covered before riding!!
 - ~~⚡~~ Take care to ensure that all wires are connected correctly, especially the <+> and <-> as incorrect installation can result in damage to the unit. Be sure to ground the shifter's <-> (black wire) to the frame.
 - ~~⚡~~ Avoid installing the control unit in places where it will be exposed to excessive water, heat, dust or vibration. Also avoid securing it the close proximity of the ignition coil or plugs as electronic noise could interfere with normal operation. We recommend installing it in a convenient spot near the CDI on the meter stay. Be sure to insert the included sponge under the control unit before securing with the provided zip straps.
-

BATTLE SHIFTER

TZ 250

INSTALLATION:

? Please refer to the wiring diagram in your owner's manual.

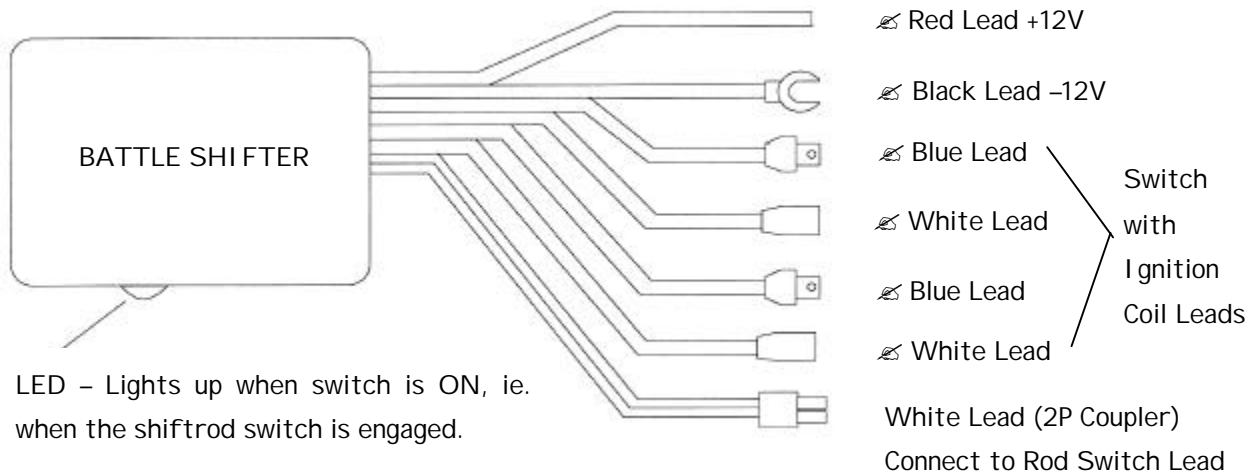

? **RED LEAD WIRE:** This becomes the Battle Shifter's 12-Volt power source. Find the red wire running from the CDI unit (located under the tachometer) to the condenser. Connect the red lead wire with the connector provided (For instructions on how to use the connector see the following page).

? **BLACK LEAD WIRE:** This is the unit's ground. Secure it with one of the 6 mm bolts that connect the meter stay to the frame.

? ? ? ? **BLUE/ WHITE LEAD WIRES:** Disconnect the couplers on the signal side of ignition coil and reconnect the orange wire from the #1 cylinder and the gray wire from the #2 cylinder to the blue and wire lead wires as per the following diagram..

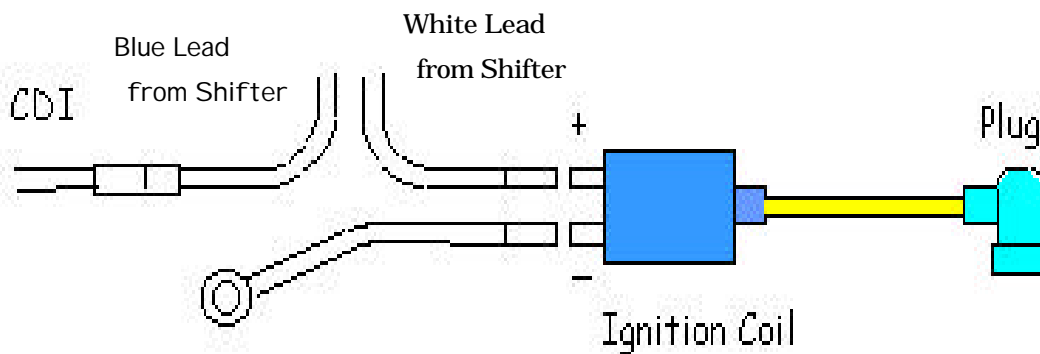

NOTE:

1. There are two pairs of blue and white lead wires. Be careful not to mix the pairs.
2. If the tachometer needle jumps a lot when setting up the shifter, interchange the blue and white lead wire pairs with the ignition coil wires.
3. Wrap electrical tape around the connections to prevent shorts.

IMPORTANT: Check to make sure that all the connectors are fastened tightly and that <+> and <-> connections are correct. Reversing <+> and <-> connections can lead to internal damage of the shifter.

CONNECTOR DIRECTIONS:

- ? <+> 12 volt lead from bike: Insert into the groove of the connector.
- ? Cap: Secure ? wire with cap.
- ? Red lead wire from the shifter: Insert into the hole of the connector.
- ? Metal tab: Compress the metal tab with pliers to secure ? and ? .
- ? Connector cap: Close the cap and you're done.

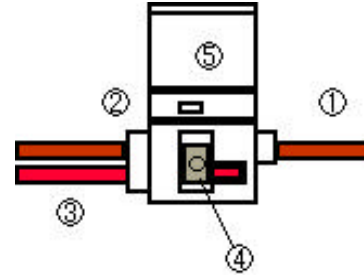

FINE TUNING:

Your Battle Shifter unit comes preset from the factory for optimal performance with your machine. However, if you absolutely feel that your unit does not shift smoothly, you can manually fine-tune it with the provided screwdriver:

Peel the tape up on the side of the unit covering the adjustment window. Adjust the volume (ignition cut time) to ensure a smooth shift with no shock when upshifting:

- rotate left to lengthen the ignition cut
- rotate right to shorten the ignition cut

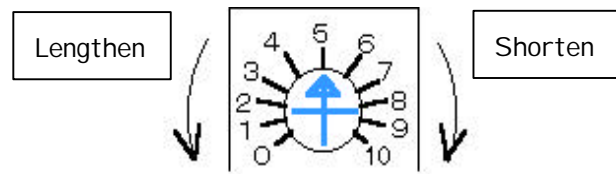

To differentiate between when the ignition cut is long and short, use the following guidelines:

- LONG: Bike pitches and/ or speed drops when changing gears. Shift is smooth.
- SHORT: Noticeable shock when changing gears. Can't get into gear at high RPM's. Shift action feels stiff.

IMPORTANT: Be sure to reseal the tape over the adjustment window before riding.

TROUBLESHOOTING:

1. The shifter doesn't cut the ignition when upshifting.

- Engine RPM's are below 3,000. The Battle Shifter automatically ceases to operate under 3,000 RPM's.
- The wires are connected improperly. Check to make sure all <+> and <-> wires are correctly connected.

2. The engine won't start.

- Be sure that you have connected the white leads from the shifter to the ignition coil with the proper pair of blue leads to the CDI.

3. The engine refuses to rev up into high RPM's.

- When the control unit is installed in a place with lots of vibration, the vibration may cause the internal relay to trip and act as a limiter. Reinstall the unit in a place with less vibration. Make sure that the rubber pad is inserted between the unit and installation surface.

4. The bike shifts fine at low RPM's, but refuses to go into gear at high RPM's.

- The ignition cut at high RPM's is too short. Return the fine-tuning volume control (left) on the unit ever so slightly.

SPECIFICATIONS:

| | | |
|-------------------|---------|-----------------|
| Voltage | | 9V – 14V |
| Power Consumption | In Rest | 12mA (12V) |
| | In Use | 37mA (12V) |
| Measurements | | 40 x 20 x 55 mm |

Manufactured by: **BATTLE FACTORY**

Suzuka, Japan
